

TV 551/701
Navigator

969-8832	969-8833
969-8834	969-8835
969-8836	969-8837
969-8922	969-8923
969-8924	969-8925
969-8926	969-8927
969-8974	969-8975

MANUALE DI ISTRUZIONI

BEDIENUNGSHANDBUCH

NOTICE DE MODE D'EMPLOI

MANUAL DE INSTRUCCIONES

MANUAL DE INSTRUÇÕES

BEDRIJFSHANDLEIDING

INSTRUKSTIONSBOG

BRUKSANVISNING

INSTRUKSJON MANUAL

OHJEKÄSIKIRJA

ΟΔΗΓΙΕΣ ΧΡΗΣΕΩΣ

INSTRUCTION MANUAL

TV 551 Navigator



TV 701 Navigator



VARIAN



vacuum technologies

Dear Customer,

Thank you for purchasing a VARIAN vacuum product. At VARIAN Vacuum Technologies we make every effort to ensure that you will be satisfied with the product and/or service you have purchased.

As part of our Continuous Improvement effort, we ask that you report to us any problem you may have had with the purchase or operation of our product. On the back side you find a Corrective Action Request form that you may fill out in the first part and return to us.

This form is intended to supplement normal lines of communications and to resolve problems that existing systems are not addressing in an adequate or timely manner.

Upon receipt of your Corrective Action Request we will determine the Root Cause of the problem and take the necessary actions to eliminate it. You will be contacted by one of our employees who will review the problem with you and update you, with the second part of the same form, on our actions.

Your business is very important to us. Please, take the time and let us know how we can improve.

Sincerely,

Sergio PIRAS

*Vice President and General Manager
VARIAN Vacuum Technologies*

Note: Fax or mail the Customer Request for Action (see backside page) to VARIAN Vacuum Technologies (Torino) - Quality Assurance or to your nearest VARIAN representative for onward transmission to the same address.

CUSTOMER REQUEST FOR CORRECTIVE / PREVENTIVE / IMPROVEMENT ACTION

TO : VARIAN VACUUM TECHNOLOGIES TORINO - QUALITY ASSURANCE

FAX N° : XXXX - 011 - 9979350

ADDRESS: VARIAN S.p.A. - Via F.lli Varian, 54 - 10040 Leinì (Torino) - Italy

E-MAIL : marco.marzio@varianinc.com

NAME _____	COMPANY _____	FUNCTION _____
<p>ADDRESS : _____</p> <p>TEL. N° : _____ FAX N° : _____</p> <p>E-MAIL : _____</p>		
<p>PROBLEM / SUGGESTION :</p> <p>_____</p> <p>_____</p> <p>_____</p> <p>_____</p>		
<p>REFERENCE INFORMATION (model n°, serial n°, ordering information, time to failure after installation, etc.) :</p> <p>_____</p> <p>_____</p> <p>_____</p> <p style="text-align: right;">DATE _____</p>		

<p>CORRECTIVE ACTION PLAN / ACTUATION (by VARIAN VTT)</p> <p>_____</p> <p>_____</p> <p>_____</p> <p>_____</p> <p>_____</p>	<p>LOG N° _____</p>
--	---------------------

XXXX = Code for dialing Italy from your country (es. 01139 from USA; 00139 from Japan, etc.)



ISTRUZIONI PER L'USO	1
GEBRAUCHSANLEITUNG	3
MODE D'EMPLOI	5
INSTRUCCIONES DE USO	7
INSTRUÇÕES PARA O USO	9
GEBRUIKSAANWIJZINGEN	11
BRUGSANVISNING	13
BRUKSANVISNING	15
BRUKERVEILEDNING	17
KÄYTTÖOHJEET	19
ΠΑΡΗΤΕΣ ΧΡΗΣΕΩΣ	21
INSTRUCTIONS FOR USE	23
TECHNICAL INFORMATION	25
DESCRIPTION OF THE TV 551/701 NAVIGATOR	25
Pump Description	26
Controller Description	26
TECHNICAL SPECIFICATION	27
TV 551/701 NAVIGATOR OUTLINE	28
INTERCONNECTIONS	31
P3 - Vent	31
P4 – External fan	31
J1 - IN-OUT	31
P2 - Serial	34
RS 232/RS 485 COMMUNICATION DESCRIPTION	34
Communication Format	34
Communication Protocol	34
Window Meanings	35
INLET SCREEN INSTALLATION	37
HEATER BAND INSTALLATION	38
AIR COOLING KIT INSTALLATION	38
TV 551/701 with Navigator Controller	38
TV 551/701 Pump with Standard Rack Controller	39
WATER COOLING KIT INSTALLATION	40
VENT ACCESSORIES	40
TV 551/701 Navigator Controller Compatible	40
Standard Rack Controller Compatible	41
VIBRATION ISOLATOR INSTALLATION	42
PURGE VALVE INSTALLATION	42
SERIAL CABLE INSTALLATION	42
TV 551/701 CONTROLLER INSTALLATION	43
TYPICAL LAYOUT DIAGRAM	44
With Navigator Controller	44
With Standard Rack Controller	44
Connection A - HIGH VACUUM FLANGE	45
Connection configurations	45

Connection B - FORE-VACUUM PUMP	46
Connection C - ELECTRICAL	46
PUMP USED WITH CORROSIVE GASES.....	46
PUMP USED IN PRESENCE OF MAGNETIC FIELDS	47
ACCESSORIES AND SPARE PARTS.....	47

INFORMAZIONI GENERALI

Questa apparecchiatura è destinata ad uso professionale. L'utilizzatore deve leggere attentamente il presente manuale di istruzioni ed ogni altra informazione aggiuntiva fornita dalla Varian prima dell'utilizzo dell'apparecchiatura. La Varian si ritiene sollevata da eventuali responsabilità dovute all'inosservanza totale o parziale delle istruzioni, ad uso improprio da parte di personale non addestrato, ad interventi non autorizzati o ad uso contrario alle normative nazionali specifiche.

Il TV 551/701 Navigator è un sistema integrato costituito da una pompa turbomolecolare per applicazioni di alto e ultra alto vuoto e dal relativo controller. Il sistema è capace di pompare qualsiasi tipo di gas o di composto gassoso, ma non è adatto per il pompaggio di liquidi o di particelle solide.

L'effetto pompante è ottenuto tramite una turbina rotante ad elevata velocità (42000 giri/min. max) mossa da un motore elettrico trifase ad alto rendimento. Il TV 551/701 Navigator è totalmente privo di agenti contaminanti, ed è quindi adatto per applicazioni che richiedono un vuoto "pulito".

Ha inoltre dei connettori ausiliari tramite i quali è possibile alimentare un ventilatore aggiuntivo, comandare la valvola di vent, pilotarlo da remoto tramite un computer host collegato con linea seriale (RS232 o RS485).

Nei paragrafi seguenti sono riportate tutte le informazioni necessarie a garantire la sicurezza dell'operatore durante l'utilizzo dell'apparecchiatura. Informazioni dettagliate sono fornite nell'appendice "Technical information".

Questo manuale utilizza le seguenti convenzioni:



PERICOLO!

I messaggi di pericolo attirano l'attenzione dell'operatore su una procedura o una pratica specifica che, se non eseguita in modo corretto, potrebbe provocare gravi lesioni personali.



ATTENZIONE!

I messaggi di attenzione sono visualizzati prima di procedure che, se non osservate, potrebbero causare danni all'apparecchiatura.

NOTA

Le note contengono informazioni importanti estrapolate dal testo.

IMMAGAZZINAMENTO

Durante il trasporto e l'immagazzinamento del TV 551/701 Navigator non devono essere superate le seguenti condizioni ambientali:

- temperatura: da -20 °C a +70 °C
- umidità relativa: 0 - 95% (non condensante)

Se il tempo di immagazzinamento è molto lungo, avviare la pompa nel modo SOFT START.

PREPARAZIONE PER L'INSTALLAZIONE

Il TV 551/701 Navigator viene fornito in un imballo protettivo speciale; se si presentano segni di danni, che potrebbero essersi verificati durante il trasporto, contattare l'ufficio vendite locale. Durante l'operazione di disimballaggio, prestare particolare attenzione a non lasciar cadere il TV 551/701 Navigator e a non sottoporlo ad urti o vibrazioni. Non disperdere l'imballo nell'ambiente. Il materiale è completamente riciclabile e risponde alla direttiva CEE 85/399 per la tutela dell'ambiente.



ATTENZIONE!

Onde evitare problemi di degasamento, non toccare con le mani nude i componenti destinati ad essere esposti al vuoto. Utilizzare sempre i guanti o altra protezione adeguata.

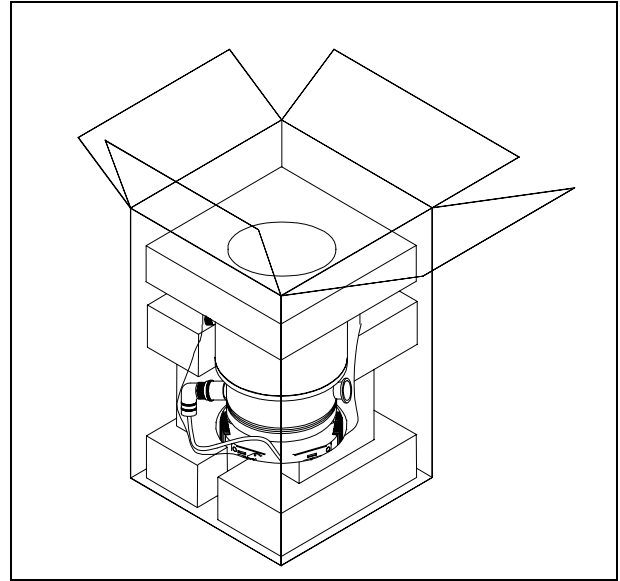

NOTA

Il TV 551/701 Navigator non può essere danneggiato rimanendo semplicemente esposto all'atmosfera. Si consiglia comunque di mantenere chiusa la pompa fino al momento dell'installazione sul sistema onde evitare eventuale inquinamento da polvere.

INSTALLAZIONE

Non installare e/o utilizzare la pompa in ambienti esposti ad agenti atmosferici (pioggia, gelo, neve), polveri, gas aggressivi, in ambienti esplosivi o con elevato rischio di incendio.

Durante il funzionamento è necessario che siano rispettate le seguenti condizioni ambientali:

- pressione massima: 2 bar oltre la pressione atmosferica
- temperatura: da + 5 °C a +35 °C (vedere grafico nell'appendice "Technical Information")
- umidità relativa: 0 - 95% (non condensante).

In presenza di campi elettromagnetici la pompa deve essere protetta tramite opportuni schermi. Vedere l'appendice "Technical Information" per ulteriori dettagli.

Il TV 551/701 Navigator deve essere collegato ad una pompa primaria (vedere schema in "Technical Information").

Il TV 551/701 Navigator può essere installato in qualsiasi posizione. Fissare il TV 551/701 Navigator in posizione stabile collegando la flangia di ingresso della turbopompa ad una controflangia fissa capace di resistere ad una coppia di 4000 Nm attorno al proprio asse.

La turbopompa con flangia di ingresso ISO deve essere fissata alla camera da vuoto per mezzo di morsetti doppi o morsetti singoli. La seguente tabella descrive, per ogni dimensione flangia e tipo di morsetto, il numero di morsetti necessari e con quale coppia di serraggio stringerli.



ATTENZIONE!

Staccare l'adesivo e togliere il tappo di protezione solo al momento del collegamento della turbopompa al sistema.

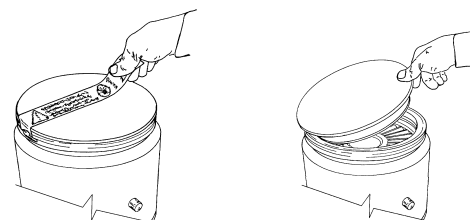

FLANGIA	TIPO DI MORSETTO	N.	COPPIA DI SERRAGGIO
ISO 100	Morsetto doppio con filettatura M10	4	22 Nm
	Morsetto singolo con filettatura M8	8	11 Nm
ISO 160	Morsetto doppio con filettatura M10	4	22 Nm
	Morsetto singolo con filettatura M10	8	22 Nm
ISO 200	Morsetto doppio con filettatura M10	6	22 Nm
	Morsetto singolo con filettatura M10	12	22 Nm

La turbopompa con flangia di ingresso ConFlat deve essere fissata alla camera da vuoto per mezzo dell'apposita minuteria meccanica Varian. Per ulteriori dettagli vedere l'appendice "Technical Information".

NOTA

Il TV 551/701 Navigator non può essere fissato tramite la sua base.



ATTENZIONE!

Il TV 551/701 Navigator appartiene alla seconda categoria di installazione (o sovratensione) prevista dalla normativa EN 61010-1. Connettere quindi il dispositivo ad una linea di alimentazione che soddisfi tale categoria.

Il TV 551/701 Navigator ha dei connettori per gli ingressi/uscite e per la comunicazione seriale che devono essere connessi ai circuiti esterni in modo che nessuna parte sotto tensione sia accessibile. Assicurarsi che l'isolamento del dispositivo connesso al TV 551/701 Navigator abbia un isolamento adeguato anche in condizione di guasto singolo come previsto dalla normativa EN 61010-1.

Per l'installazione degli accessori opzionali, vedere "Technical Information".

USO

In questo paragrafo sono riportate le principali procedure operative.

Prima di usare il sistema effettuare tutti i collegamenti elettrici e pneumatici. Durante l'eventuale riscaldamento della camera da vuoto, la temperatura sulla flangia di ingresso non deve essere superiore a 120 °C.



PERICOLO!

Non far funzionare mai la pompa se la flangia di ingresso non è collegata alla camera a vuoto o non è chiusa con la flangia di chiusura.

Non toccare la turbopompa e i suoi eventuali accessori durante le operazioni di riscaldamento. L'elevata temperatura può causare lesioni alle persone.



ATTENZIONE!

Evitare urti, oscillazioni o bruschi spostamenti della turbopompa quando è in funzione. I cuscinetti potrebbero danneggiarsi.

Per la mandata all'aria della pompa utilizzare aria o gas inerte esente da polvere o particelle. La pressione di ingresso attraverso l'apposita porta deve essere inferiore a 2 bar (oltre la pressione atmosferica).

Per il pompaggio di gas aggressivi queste pompe sono dotate di una apposita porta attraverso la quale è necessario fornire alla pompa un flusso di gas inerte (Azoto o Argon) per proteggere i cuscinetti (vedere l'appendice "Technical Information").



PERICOLO!

Quando la pompa viene utilizzata per il pompaggio di gas tossici, infiammabili o radioattivi, seguire le appropriate procedure tipiche di ciascun gas.

Non usare la pompa in presenza di gas esplosivi.

Accensione ed Uso del TV 551/701 Navigator

Per accendere il TV 551/701 Navigator è sufficiente fornire la tensione di alimentazione. Il controller incorporato riconosce automaticamente la presenza dei segnali di interlock e di avvio ed avvia la pompa.

La prima partenza della pompa avviene nel modo "Soft Start" che, al termine del ciclo di avvio, si disabilita automaticamente, per cui tutti i successivi avvii della pompa avvengono senza il modo "Soft Start". Per riavere una partenza con "Soft Start" attivo occorre riabilitare il modo suddetto tramite software (vedere il paragrafo "RS 232/485 COMMUNICATION DESCRIPTION" nell'appendice "Technical Information").

Il LED verde posto sul pannello della base del TV 551/701 Navigator indica, con la frequenza del suo lampeggio, le condizioni operative del sistema:

- acceso fisso: la pompa è in rotazione normale;
- lampeggiante lentamente (periodo di circa 400 ms): il sistema è in stato di rampa, o di frenata, o di Stop, o di "Waiting for interlock";
- lampeggiante velocemente (periodo di circa 200 ms): condizione di errore.

Arresto del TV 551/701 Navigator

Per arrestare il TV 551/701 Navigator è sufficiente togliere la tensione di alimentazione. Il controller incorporato arresta immediatamente la pompa.

Arresto di Emergenza

Per arrestare in condizioni di emergenza il TV 551/701 Navigator occorre staccare il cavo di alimentazione dal controller.

MANUTENZIONE

Il TV 551/701 Navigator non richiede alcuna manutenzione. Qualsiasi intervento deve essere eseguito da personale autorizzato.



PERICOLO!

Prima di effettuare qualsiasi intervento sul sistema scollegarlo dall'alimentazione, mandare all'aria la pompa aprendo l'apposita valvola, attendere fino al completo arresto del rotore ed attendere che la temperatura superficiale della pompa sia inferiore a 50°C.

In caso di guasto è possibile usufruire del servizio di riparazione Varian o del "Varian advanced exchange service", che permette di ottenere un sistema rigenerato in sostituzione di quello guasto.

NOTA

Prima di rispedire al costruttore un sistema per riparazioni o advanced exchange service, è indispensabile compilare e far pervenire al locale ufficio vendite la scheda "Sicurezza e Salute" allegata al presente manuale di istruzioni. Copia della stessa deve essere inserita nell'imballo del sistema prima della spedizione.

Qualora un sistema dovesse essere rottamato, procedere alla sua eliminazione nel rispetto delle normative nazionali specifiche.

ALLGEMEINE INFORMATIONEN

Dieser Apparat ist für den fachmännischen Gebrauch bestimmt. Vor dem Gebrauch hat der Benutzer dieses Handbuch sowie alle weiteren mitgelieferten Zusatzdokumentationen genau zu lesen. Bei auch teilweiser Nichtbeachtung der enthaltenen Anweisungen, unsachgemäßem Gebrauch durch ungeschultes Personal, nicht autorisierten Eingriffen und Mißachtung der nationalen einschlägigen Normen übernimmt die Firma Varian keinerlei Haftung.

Modell TV 551/701 Navigator ist ein integriertes System, das aus einer Turbomolekularpumpe für Hoch- und Höchstvakuumanwendungen, integriert mit einem entsprechenden Controller, besteht. Das System eignet sich für die Förderung aller Arten von Gasen oder gashaltigen Gemischen, nicht jedoch für die Förderung von Flüssigkeiten oder Festpartikeln.

Die Pumpwirkung wird durch eine hochtourige Turbine (max. 42.000 1/min) erreicht, die von einem Hochleistungs-drehstrommotor angetrieben wird. Modell TV 551/701 Navigator enthält keinerlei umweltschädliche Substanzen und eignet sich deshalb auch für Anwendungen, die ein "sauberes" Vakuum erfordern.

Modell TV 551/701 Navigator verfügt des weiteren über Zusatzanschlüsse, über die ein zusätzlicher Ventilator versorgt, das Entlüftungsventil gesteuert oder die Vorrichtung von einem Host Computer über eine serielle Leitung gesteuert werden kann (RS232, RS485).

In den folgenden Abschnitten sind alle erforderlichen Informationen für die Sicherheit des Bedieners bei der Anwendung des Geräts aufgeführt. Detaillierte technische Informationen sind im Anhang "Technical Information" enthalten.

In dieser Gebrauchsanleitung werden Sicherheitshinweise folgendermaßen hervorgehoben:



GEFAHR!

Die Gefahrenhinweise lenken die Aufmerksamkeit des Bedieners auf einen Vorgang oder eine bestimmte Ausführungsweise, die bei unkorrekter Ausführung schwere Verletzungen hervorrufen könnten.



ACHTUNG!

Die Warnhinweise werden vor Vorgängen angegeben, die bei Nichtbeachtung Schäden an der Anlage verursachen könnten.

HINWEIS

Die Hinweise enthalten wichtige Informationen, die aus dem Text hervorgehoben werden.

LAGERUNG

Beim Transport und bei der Lagerung von Modell TV 551/701 navigator sollen die folgenden Umgebungsbedingungen gewährleistet sein:

- Temperatur: von -20 °C bis +70 °C
 - Relative Luftfeuchtigkeit: 0 - 95 % (nicht kondensierend)
- Nach sehr langen Lagerzeiten ist die Pumpe im Modus "SOFT START" ingangzusetzen.

VOR DER INSTALLATION

Modell TV 551/701 Navigator wird in einer speziellen Schutzverpackung geliefert. Eventuelle Transportschäden sind der zuständigen örtlichen Verkaufsstelle zu melden. Modell TV 551/701 Navigator ist vorsichtig auszuwickeln, wobei es vor dem Herunterfallen und vor Stößen und Vibrationen zu schützen ist.

Das Verpackungsmaterial ist vorschriftsgemäß zu entsorgen. Es ist vollständig recyclebar und entspricht der Richtlinie 85/399/EWG für Umweltschutz.



ACHTUNG!

Um Entgasungen zu vermeiden, dürfen die Teile, die mit dem Vakuum in Berührung kommen, nicht mit den bloßen Händen angefaßt werden. Es sind stets Schutzhandschuhe oder andere Schutzmittel zu verwenden.

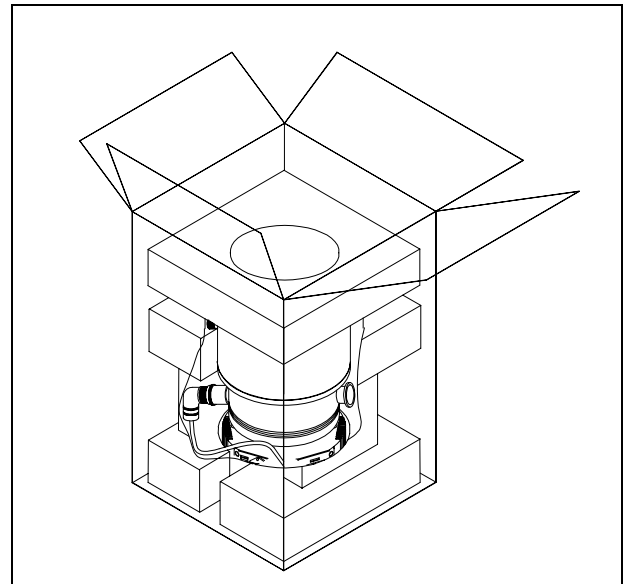

HINWEIS

Modell TV 551/701 Navigator kann durch die Umgebung an sich keine Schäden erleiden. Es sollte jedoch bis zur Installation an der Anlage geschlossen bleiben, um Verunreinigungen durch Staub zu vermeiden.

INSTALLATION

Die Pumpe darf nicht in Umgebungen, die ungeschützt vor Wetter (Regen, Frost, Schnee), Staub und aggressiven Gasen sind, sowie auch nicht in explosionsfähigen oder erhöht brandgefährdeten Umgebungen installiert und/oder benutzt werden.

Beim Betrieb müssen folgende Umgebungsbedingungen eingehalten werden:

- Maximaler Druck: 2 bar über dem atmosphärischen Druck
- Temperatur: von +5°C bis +35°C (siehe Diagramm im Anhang "Technical Information")
- Relative Luftfeuchtigkeit: 0 - 95% (nicht kondensierend).

Bei Vorhandensein von elektromagnetischen Feldern ist die Pumpe entsprechend abzuschirmen. Für ausführliche Informationen siehe im Anhang "Technical Information".

Modell TV 551/701 Navigator ist an eine Primärpumpe anzuschließen (siehe Schema in "Technical Information").

Modell TV 551/701 Navigator kann in jeder beliebigen Position installiert werden. Modell TV 551/701 Navigator ist stabil zu befestigen, indem der Flansch am Eingang der Turbopumpe an einen festen Gegenflansch angeschlossen wird, der mit einem Drehmoment von 4000 Nm um seine eigene Achse belastbar ist. Turbopumpen mit einem ISO-Eingangsfansch sind mittels doppelter oder einfacher Klemmschellen an die Vakuumkammer anzuschließen. In der nachstehenden Tabelle sind die Anzahl der Klemmschellen und das Anzugsmoment für die jeweiligen Flanschgrößen und Schellenarten angegeben.



ACHTUNG!

Das Klebeband abziehen und den Schutzdeckel erst bei Anschluß der Turbopumpe an das System abnehmen.

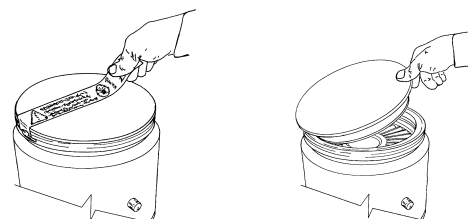

FLANSCH	KLEMMSCHELLE	ANZ.	ANZUGSMOMENT
ISO 100	Doppelschelle mit Gewinde M10	4	22 Nm
	Einzelchelle mit Gewinde M8	8	11 Nm
ISO 160	Doppelschelle mit Gewinde M10	4	22 Nm
	Einzelchelle mit Gewinde M10	8	22 Nm
ISO 200	Doppelschelle mit Gewinde M10	6	22 Nm
	Einzelchelle mit Gewinde M10	12	22 Nm

Turbopumpen mit ConFlat-Eingangsflansch sind mit dem speziellen Varian-Befestigungsmaterial an die Vakuumkammer anzuschließen. Für ausführliche Informationen siehe im Anhang "Technical Information".

HINWEIS

Modell TV 551/701 Navigator kann nicht mittels seines Sockels befestigt werden.

ACHTUNG!

Der TV 551/701 Navigator gehört zur zweiten Installationsklasse (Überdruck) die von den Normen EN 61010-1 vorgesehen ist. Die Vorrichtung muß daher an eine Speisungsleitung angeschlossen werden, die dieser Kategorie entspricht.

Der TV 551/701 Navigator hat Verbinder für den Ein- und Ausgang und die Schnittstellenkommunikation, die an die Außenkreise angeschlossen werden müssen, sodaß kein Teil unter Spannung zugänglich ist. Sicherstellen, daß die Isolierung der an den TV 551/701 Navigator angeschlossenen Vorrichtung auch bei einer Einzelstörung ausreichend isoliert, wie es von der Richtlinie EN 61010-1 vorgesehen wird.

Für die Installation der Optionsteile siehe im Anhang "Technical Information".

GEBRAUCH

In diesem Abschnitt werden die wichtigsten Betriebsvorgänge erläutert. Vor Benutzung des Systems sind alle elektrischen und pneumatischen Anschlüsse auszuführen. Während der eventuellen Aufheizung der Vakuumkammer darf die Temperatur am Eingangsflansch 120°C nicht überschreiten.

GEFAHR!

Die Pumpe darf nicht in Betrieb genommen werden, wenn der Eingangsflansch nicht an die Vakuumkammer angeschlossen oder nicht mit dem Verschlussflansch verschlossen ist. Während des Aufheizens dürfen weder die Pumpe noch eventuelle heiße Zubehörteile berührt werden. Es besteht Verbrennungsgefahr.

ACHTUNG!

Während des Betriebs sind Stoß- und Vibrationseinwirkungen sowie Ruckbewegungen an der Turbopumpe zu vermeiden, da die Lager beschädigt werden könnten.

Für die Belüftung der Pumpe trockene staub- und partikelfreie Luft oder Inertgase verwenden. Der Eingangsdruck am Belüftungsanschluß soll unter 2 bar (über dem atmosphärischen Druck) betragen. Zum Pumpen von aggressiven Gasen sind die Pumpen mit einer Öffnungsklappe ausgestattet, über die zum Schutz der Lager Inertgas (Stickstoff oder Argon) zuzuleiten ist (siehe Anhang "Technical Information").

GEFAHR!

Wenn die Pumpe zur Förderung von giftigen, leicht entflammaren oder radioaktiven Gasen benutzt wird, sind die für das jeweilige Gas vorgeschriebenen Vorgänge und Maßnahmen zu befolgen.

Die Pumpe darf niemals bei Vorhandensein von explosionsfähigen Gasen verwendet werden.

Einschaltung und Gebrauch von Modell TV 551/701 Navigator

Zur Einschaltung von Modell TV 551/701 ist es mit der erforderlichen Versorgungsspannung zu versorgen. Der eingebaute Controller erfaßt automatisch das Vorhandensein von Interlock- und Anlaufsignalen und startet die Pumpe.

Die Erstinbetriebnahme der Pumpe erfolgt im Modus "Soft Start", der sich nach dem Anlaufzyklus selbsttätig abschaltet. Daher erfolgen alle nachfolgenden Pumpenanläufe ohne den Modus "Soft Start". Um die Pumpe erneut im Modus "Soft Start" zu starten, ist dieser Modus mittels der Software wieder freizugeben (siehe Abschnitt "RS 232 COMMUNICATION DESCRIPTION" im Anhang "Technical Information").

Die grüne LED LD1 an der Bodenplatte von Modell TV 551/701 gibt mit der Häufigkeit ihres Blinkens die Betriebsbedingungen des System an:

- Daueranzeige: Die Pumpe befindet sich im normalen Betrieb.
- Langsame Blinkanzeige (ca. 400 ms): das System befindet sich entweder im Status Rampe, Abbremsung, Stopp oder "Waiting for Interlock".
- Schnelle Blinkanzeige (ca. 200 ms): Fehlerstatus.

Stoppen von Modell TV 551/701 Navigator

Zum Stoppen von Modell TV 551/701 Navigator ist die Versorgungsspannung abzuschalten. Der eingebaute Controller sorgt für den sofortigen Pumpenstopp.

Not-Aus

Zur Stillsetzung von Mod. TV 551/701 Navigator in Notsituationen ist vom Controller das Netzkabel abzuziehen.

WARTUNG

Modell TV 551/701 Navigator erfordert keine Wartung. Eventuelle Eingriffe dürfen nur von autorisiertem Fachpersonal ausgeführt werden.

GEFAHR!

Vor jedem Eingriff am System den Netzstecker ziehen, die Pumpe über Öffnung des entsprechenden Ventils belüften und abwarten, bis der Rotor vollkommen stillsteht und die Temperatur am Pumpengehäuse unter 50°C abgesunken ist.

Bei Defekten kann der Varian Service oder der "Varian advanced exchange service" in Anspruch genommen werden, der ein generalüberholtes System als Ersatz für das defekte System zur Verfügung stellt.

HINWEIS

Bevor Fa. Varian ein System zur Reparatur oder den Umtauschdienst eingesandt wird, ist das Formular "Sicherheit und Gesundheit", das diesem Handbuch beiliegt, ausgefüllt an die örtliche Verkaufsstelle zu senden. Eine Kopie ist der Verpackung des Systems vor dem Versand beizulegen.

Eine eventuelle Verschrottung hat unter Beachtung der einschlägigen nationalen Vorschriften zu erfolgen.

INDICATIONS GENERALES

Cet appareillage a été conçu en vue d'une utilisation professionnelle. Avant toute utilisation de l'appareil, il est conseillé à l'utilisateur de lire attentivement cette notice d'instructions ainsi que toute autre indication supplémentaire fournie par Varian qui décline par conséquent toute responsabilité en cas de non respect total ou partiel des instructions données, d'utilisation impropre par un personnel non formé, d'opérations non autorisées ou d'emploi contraire aux réglementations nationales spécifiques. Le TV 551/701 Navigator est un système intégré, constitué d'une pompe turbomoléculaire conçue pour des applications de vide poussé et ultrapoussé et doté d'un contrôleur. Le système est à même de pomper tous les types de gaz et de composés gazeux mais il n'est pas adapté au pompage de liquides ou de particules solides. L'effet de pompage est obtenu grâce à une turbine tournant à vitesse élevée (42000 tr/min maxi), mue par un moteur électrique triphasé à haut rendement. Le TV 551/701 Navigator est totalement exempt d'agents polluants et il est par conséquent indiqué pour toutes les applications exigeant un vide "propre". Le TV 551/701 Navigator est en outre doté de connecteurs auxiliaires permettant d'alimenter un ventilateur supplémentaire, de commander la soupape de ventilation, de le piloter à distance à l'aide d'un ordinateur host connecté par ligne sérielle. Les paragraphes suivants fournissent toutes les indications nécessaires à garantir la sécurité de l'opérateur pendant l'utilisation de l'appareillage. Des renseignements plus détaillés se trouvent dans l'appendice "Technical Information".

Cette notice utilise les signes conventionnels suivants:



DANGER!

Les messages de danger attirent l'attention de l'opérateur sur une procédure ou une manœuvre spéciale qui, effectuée de façon impropre, risque de provoquer de graves lésions



ATTENTION!

Les messages d'attention apparaissent avant certaines procédures dont le non respect pourrait endommager sérieusement l'appareillage.

NOTE

Les notes contiennent des renseignements importants, extrapolés du texte.

STOCKAGE

Pendant le transport et le stockage du TV 551/701 Navigator, veiller au respect des conditions environnementales suivantes:

- température: de - 20°C - à + 70°C
- humidité relative: 0 - 95 % (non condensante)

Si le temps de stockage est très long, mettre la pompe en marche en mode SOFT START

PREPARATION POUR L'INSTALLATION

Le TV 551/701 Navigator est livré dans un emballage de protection spécial; en cas d'endommagement de l'emballage pouvant s'être produit pendant le transport, contacter le bureau de vente local.

Pendant l'opération d'ouverture de l'emballage, veiller tout particulièrement à ne pas laisser tomber le TV 551/701 Navigator et à ne lui faire subir aucun choc et aucune vibration. Ne pas abandonner l'emballage dans la nature. Le matériel est entièrement recyclable et conforme à la directive CEE 85/399 en matière de protection de l'environnement.



ATTENTION!

Afin d'éviter tout problème de dégazage, ne pas toucher, à mains nues, les éléments devant être exposés au vide. Mettre toujours des gants ou toute autre protection appropriée.

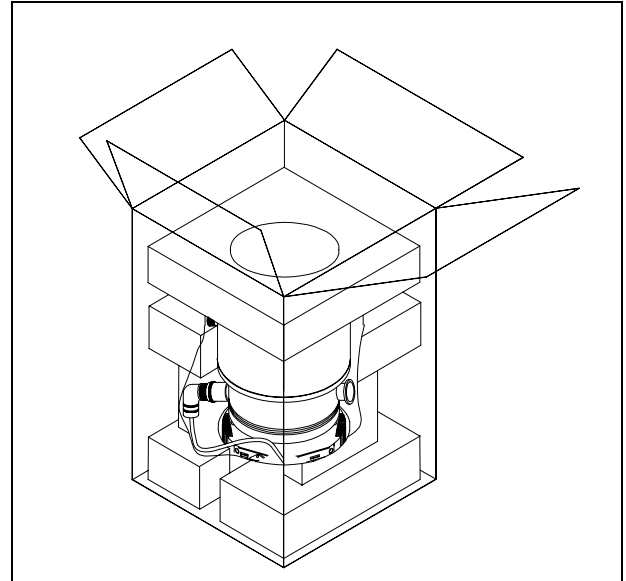

NOTE

Le TV 551/701 ne peut s'endommager en restant simplement exposé à l'atmosphère. Toutefois, afin d'éviter toute pollution due à la poussière, il est conseillé de le garder dans son emballage clos jusqu'au moment de l'installation.

INSTALLATION

Ne pas installer et/ou utiliser la pompe dans des milieux exposés aux agents atmosphériques (pluie, gel, neige), à la poussière, aux gaz agressifs ainsi que dans des milieux explosifs ou à fort risque d'incendie.

Pendant le fonctionnement, il est nécessaire de respecter les conditions environnementales suivantes:

- pression maxi: 2 bar au-delà de la pression atmosphérique
- température: de +5°C° à +35°C (Cf. graphique dans "Technical Information")
- humidité relative: 0 - 95% (non condensante)

En présence de champs magnétiques, la pompe doit être protégée à l'aide d'écrans appropriés. Pour tout autre renseignement, se reporter à l'opuscule "Technical Information". Le TV 551/701 Navigator doit être connecté à une pompe primaire (Cf. schéma dans "Technical Information").

Le TV 551/701 Navigator peut être installée dans n'importe quelle position. Le fixer dans une position stable, en reliant la bride d'entrée de la turbopompe à une contre-bride fixe pouvant supporter un couple de serrage de 4000 Nm autour de son axe. La turbopompe à bride d'entrée ISO doit être fixée à la chambre à vide à l'aide de colliers doubles ou simples. Le tableau suivant décrit, pour chaque dimension de bride et pour chaque type de collier, le nombre de colliers nécessaires ainsi que le couple de serrage prescrit.



ATTENTION!

Ne décoller l'adhésif et ne retirer le couvercle de protection qu'au moment de brancher la turbopompe au système.

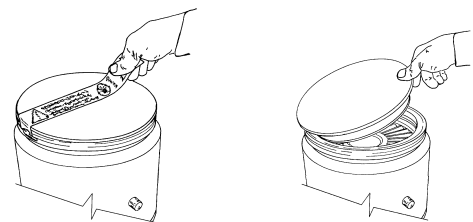

BRIDE	TYPE DE COLLIER	N.	COUPLE DE SERRAGE
ISO 100	Collier double à filet M10	4	22 Nm
	Collier simple à filet M8	8	11 Nm
ISO 160	Collier double à filet M10	4	22 Nm
	Collier simple à filet M10	8	22 Nm
ISO 200	Collier double à filet M10	6	22 Nm
	Collier simple à filet M10	12	22 Nm

La turbopompe à bride d'entrée ConFlat doit être fixée à la chambre à vide à l'aide des éléments mécaniques Varian prévus à cet effet. Pour tout autre détail, se reporter à l'appendice "Technical Information".

NOTE

Le TV 551/701 Navigator ne peut être fixé par sa base.

 **ATTENTION!**

Le TV 551/701 Navigator appartient à la deuxième catégorie d'installations (ou surtension) prévue par la norme EN 61010-1. De ce fait, brancher le dispositif à une ligne d'alimentation compatible avec cette catégorie.

Le TV 551/701 Navigator dispose de connecteurs pour les entrées/sorties et pour la communication en série qui doivent être branchés aux circuits extérieurs de façon qu'aucune partie sous tension ne soit accessible.

S'assurer que l'isolation du dispositif branché au TV 551/701 Navigator a une isolation appropriée même en condition de panne individuelle selon les termes de la norme EN 61010-1.

Pour l'installation des accessoires en option, se reporter à "Technical Information".

UTILIZATION

Ce paragraphe présente les principales procédures opérationnelles.

Avant d'utiliser le système, effectuer tous les branchements électriques et pneumatiques. Pendant le chauffage éventuel de la chambre à vide, la température de la bride d'entrée ne doit pas dépasser 120°C.

 **DANGER!**

Ne jamais faire fonctionner la pompe si la bride d'entrée n'est pas reliée à la chambre à vide ou si elle n'est pas fermée avec la bride de fermeture.

Eviter de toucher la turbopompe ainsi que ses accessoires éventuels pendant les opérations de chauffage. La température élevée peut être à l'origine de lésions graves.

 **ATTENTION!**

Lorsque la turbopompe fonctionne, éviter tout choc, oscillation ou déplacement brusque car les paliers pourraient se détériorer.

Pour le refoulement de l'air de la pompe, utiliser de l'air ou du gaz inerte exempt de poussière ou de particules. La pression d'entrée à travers la porte prévue à cet effet doit être inférieure à 2 bar (au-delà de la pression atmosphérique).

Pour le pompage de gaz agressifs, ces pompes sont dotées d'une porte spéciale à travers laquelle il est nécessaire de fournir à la pompe un flux de gaz inerte (azote ou argon) pour protéger les paliers (voir l'appendice "Technical Information").



DANGER!

Lorsque la pompe est utilisée pour le pompage de gaz toxiques, inflammables ou radioactifs, suivre les procédures typiques de chaque gaz.

Ne pas utiliser la pompe en présence de gaz explosifs.

Mise en marche et utilisation du TV 551/701 Navigator

Pour allumer le TV 551/701 Navigator il suffit de fournir la tension d'alimentation. Le contrôleur incorporé reconnaît automatiquement la présence de signaux d'interlock et de démarrage et il actionne la pompe.

La première mise en marche de la pompe se fait en mode "Soft Start". Au terme du cycle de démarrage, ce mode se désactive automatiquement et les mises en marche suivantes se font sans le passage "Soft Start". Pour obtenir à nouveau une mise en marche "Soft Start", il faut réactiver ce mode opératoire à l'aide du logiciel (Cf. paragraphe "RS232 COMMUNICATION DESCRIPTION" dans l'appendice "Technical Information").

La LED verte LD1 placée sur le panneau de la base du TV 551/701 indique, par sa fréquence de clignotement, les conditions opérationnelles du système:

- allumée fixe: la pompe est en rotation normale;
- clignote lentement (période d'environ 400 ms): le système est en état de rampe, de freinage, de stop ou d'attente interlock.
- clignote rapidement (période d'environ 200 ms): condition d'erreur.

Arrêt du TV 551/701 Navigator

Pour arrêter le TV 551/701 Navigator, il suffit de retirer la tension d'alimentation. Le contrôleur incorporé arrête immédiatement la pompe.

Arrêt d'urgence

Pour arrêter le TV 551/701 Navigator en conditions d'urgence, il faut débrancher le cordon d'alimentation du contrôleur.

ENTRETIEN

Le TV 551/701 Navigator n'exige aucun entretien particulier. Toute intervention doit être effectuée par un personnel agréé.



DANGER!

Avant toute intervention sur le système, le débrancher, refouler l'air de la pompe en ouvrant la soupape prévue à cet effet, attendre jusqu'à l'arrêt complet du rotor et jusqu'à ce que la température superficielle de la pompe soit inférieure à 50°C.

En cas de panne, il est possible de bénéficier du service réparations Varian ou du "Varian advanced exchange service" qui permet d'obtenir un système régénéré en remplacement du système endommagé.

NOTE

Avant de renvoyer une pompe au constructeur pour réparation ou "advanced exchange service", remplir et faire parvenir au bureau Varian de votre région la fiche "Sécurité et Santé" jointe au présent manuel d'instructions. Une copie de cette fiche devra être mise dans l'emballage de la pompe avant l'expédition.

En cas de mise au rebut de la pompe, procéder à son élimination conformément aux réglementations nationales concernant la gestion des déchets.

INFORMACIÓN GENERAL

Este equipo es para uso profesional. El usuario ha de leer atentamente el presente manual de instrucciones y cualquier otra información suplementaria facilitada por Varian antes de usar el aparato. Varian se considera libre de posibles responsabilidades debidas al incumplimiento total o parcial de las instrucciones, al uso impropio por parte de personal no preparado, a operaciones no autorizadas o a un uso contrario a las normas nacionales específicas.

El TV 551/701 Navigator es un sistema integrado compuesto por una bomba turbomolecular para aplicaciones de alto y ultra alto vacío integrada por el controler correspondiente. El sistema puede bombear cualquier tipo de gas o de composición gaseosa, pero no es adecuado para bombear líquidos o partículas sólidas.

El efecto de bombeo se obtiene mediante una turbina rotativa de alta velocidad (42000 r.p.m. máx.) movida por un motor eléctrico trifásico de alto rendimiento. El TV 551/701 Navigator no posee ningún agente contaminante y por lo tanto es adecuado para aplicaciones que requieren un vacío "limpio".

Asimismo, el TV 551/701 Navigator posee conectores auxiliares con los que se puede alimentar un ventilador adicional, accionar la válvula de ventilación, pilotarla a distancia con un ordenador host conectado mediante línea serial (RS 232/RS 485).

A continuación se facilita toda la información necesaria para garantizar la seguridad del operador al usar el aparato. En el anexo "Technical Information" se facilita información más detallada.

Este manual utiliza las convenciones siguientes:



¡PELIGRO!

Los mensajes de peligro atraen la atención del operador sobre un procedimiento o una ejecución específica que, de no realizarse correctamente, podría provocar graves lesiones personales.



¡ATENCIÓN!

Los mensajes de atención se visualizan antes de los procedimientos que, de no cumplirse, podrían provocar daños al aparato.

NOTA

Las notas contienen información importante extraída del texto.

ALMACENAMIENTO

Durante el transporte y el almacenamiento del TV 551/701 Navigator no han de superarse las condiciones ambientales siguientes:

- temperatura : de - 20°C a +70°C
- humedad relativa: 0 -95% (no condensadora)

Si el periodo de almacenamiento es muy largo, poner en marcha la bomba en el modo SOFT START.

PREPARACIÓN PARA LA INSTALACIÓN

El TV 551/701 Navigator se suministra en un embalaje especial de protección; si se observan daños, que podrían haberse producido durante el transporte, ponerse en contacto con la oficina local de ventas.

Durante la operación de desembalaje, tener cuidado de que no se caiga el TV 551/701 Navigator y de no someterlo a golpes o vibraciones.

No abandonar el embalaje en el medio ambiente. El material es completamente reciclable y cumple con la directiva CEE 85/399 para la preservación del medio ambiente.



¡ATENCIÓN!

Para evitar problemas de desgasificación, no tocar con las manos desnudas los componentes destinados a exponerse al vacío. Utilizar siempre guantes u otra protección adecuada.

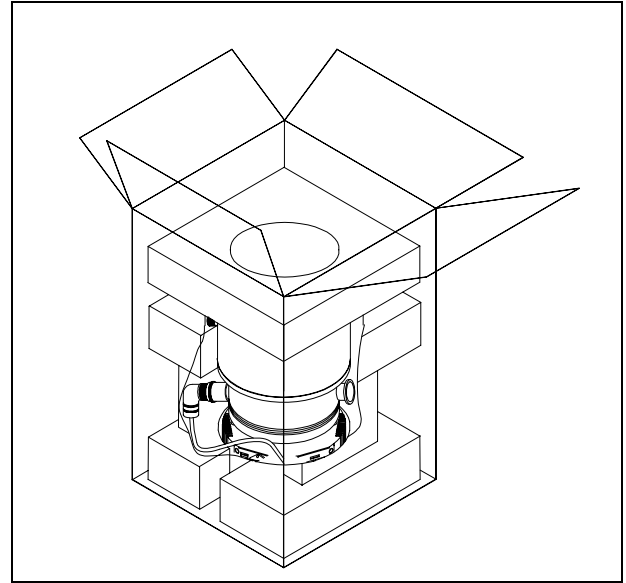

NOTA

El TV 551/701 Navigator no puede dañarse permaneciendo simplemente expuesto a la atmósfera. De todas formas, se aconseja mantener cerrada la bomba hasta que se instale en el sistema para evitar su posible contaminación por polvo.

INSTALACIÓN

No instalar ni/o utilizar la bomba en lugares expuestos a agentes atmosféricos (lluvia, hielo y nieve), polvo y gases agresivos, en lugares explosivos o con alto riesgo de incendio. Durante el funcionamiento es necesario que se respeten las condiciones ambientales siguientes:

- presión máxima: 2 bares por encima de la presión atmosférica
- temperatura: de +5°C a +35°C (véase gráfico en el anexo "Technical Information")
- humedad relativa: 0-95% (no condensadora).

Cuando existan campos electromagnéticos, la bomba ha de protegerse mediante pantallas oportunas. Véase el anexo "Technical Information" para más detalles.

El TV 551/701 Navigator ha de conectarse a una bomba primaria (véase diagrama en "Technical Information").

El TV 551/701 Navigator puede instalarse en cualquier posición. Fijar el TV 551/701 Navigator en posición estable conectando la brida de entrada de la turbobomba a una contrabrida fija que puede resistir a un par de 4000 Nm alrededor de su eje. La turbobomba con brida de entrada ISO ha de fijarse a la cámara de vacío mediante mordazas dobles o mordazas sencillas. La tabla siguiente describe, por cada dimensión de la brida y tipo de mordaza, el número de mordazas necesarias y con qué par de apriete apretarlas.



¡ATENCIÓN!

Despegar el adhesivo y quitar el tapón de protección sólo al conectar la bomba al sistema.

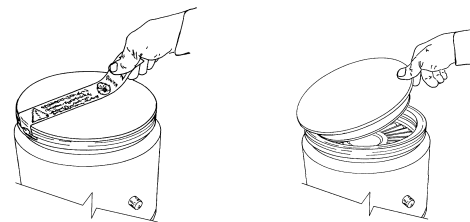

BRIDA	TIPO DE MORDAZA	N.	PAR DE APRIETE
ISO 100	Mordaza doble con rosca M10	4	22 Nm
	Mordaza sencilla con rosca M8	8	11 Nm
ISO 160	Mordaza doble con rosca M10	4	22 Nm
	Mordaza sencilla con rosca M10	8	22 Nm
ISO 200	Mordaza doble con rosca M10	6	22 Nm
	Mordaza sencilla con rosca M10	12	22 Nm

La turbobomba con brida de entrada ConFlat ha de fijarse a la cámara de vacío mediante los accesorios mecánicos específicos Varian. Para más detalles véase el anexo "Technical Information".

NOTA

El TV 551/701 Navigator no puede fijarse utilizando su base.



¡ATENCIÓN!

El TV 551/701 Navigator pertenece a la segunda categoría de instalación (o sobretensión) prevista por la normativa EN 61010-1. Por lo tanto este dispositivo debe ser conectado a una línea de alimentación adecuada para dicha categoría.

El TV 551/701 Navigator tiene conectores para las entradas/salidas y para la comunicación serial que deben ser conectados a los circuitos externos de manera que ninguna parte bajo tensión quede accesible. Controlar que el aislamiento del dispositivo conectado al TV 551/701 Navigator mantenga una acción aisladora incluso en caso de verificarse una avería, de conformidad con lo establecido por la normativa EN 61010-1.

Para instalar los accesorios opcionales, véase "Technical Information".

USO

En este apartado se citan los procedimientos operativos principales. Antes de usar el sistema realizar todas las conexiones eléctricas y neumáticas. Durante el posible calentamiento de la cámara de vacío, la temperatura de la brida de entrada no ha de ser superior a 120°C.



¡PELIGRO!

No hacer funcionar nunca la bomba si la brida de entrada no está conectada al sistema o no está cerrada con la brida de cierre.

No tocar la turbobomba y sus posibles accesorios durante las operaciones de calentamiento. La alta temperatura puede provocar lesiones a las personas.



¡ATENCIÓN!

Evitense golpes, oscilaciones o bruscos desplazamientos de la turbobomba durante su funcionamiento. Los cojinetes podrían dañarse.

Para el envío de aire de la bomba utilizar aire o gas inerte sin polvo o partículas. La presión de entrada a través de la puerta deberá ser inferior a 2 bar (por encima de la presión atmosférica). Para bombear gases agresivos estas bombas están dotadas de una puerta específica mediante la cual es necesario suministrar a la bomba un caudal de gas inerte (Nitrógeno o Argón) para proteger los rodamientos (véase el anexo "Technical Information").



¡PELIGRO!

Cuando la bomba se utiliza para bombear gases tóxicos, inflamables o radioactivos, seguir los procedimientos apropiados típicos de cada gas. No usar la bomba cuando haya gases explosivos.

Encendido y Uso del TV 551/701 Navigator

Para encender el TV 551/701 Navigator basta con suministrar la tensión de alimentación. El controlador incorporado reconoce automáticamente la presencia de las señales de interbloqueo y de arranque y activa la bomba.

La primera salida de la bomba se realiza en el modo "Soft Start" que, al final del ciclo de puesta en marcha, se deshabilita automáticamente, por lo tanto cuando la bomba se ponga en marcha posteriormente se hará sin "Soft Start". Para volver a utilizar una puesta en marcha "Soft Start" activa es necesario rehabilitar la forma anteriormente indicada mediante software (véase el apartado "RS 232 COMMUNICATION DESCRIPTION" en el anexo "Technical Information").

El LED verde LD1 situado en el panel de la base del TV 551/701 indica, con la frecuencia de su parpadeo, las condiciones operativas del sistema:

- encendido fijo: la bomba está en rotación normal;
- parpadea lentamente (periodo de 400 ms aproximadamente): el sistema está en estado de rampa, o de frenado, o de stop, o de "waiting for interlock";
- parpadea rápidamente (periodo de 200 ms aproximadamente): condición de error.

Parada del TV 551/701 Navigator

Para parar el TV 551/701 Navigator nte con desenchufarlo de la corriente. El controlador incorporado detiene inmediatamente la bomba.

Parada de Emergencia

Para detener en condiciones de emergencia el TV 551/701 Navigator es necesario desconectar del controlador el cable de alimentación.

MANTENIMIENTO

El TV 551/701 Navigator no necesita ningún mantenimiento. Cualquier operación deberá ser realizada por personal autorizado.



¡PELIGRO!

Antes de realizar cualquier operación en el sistema desconectarlo de la corriente, enviar aire de la bomba abriendo la válvula oportuna, esperar hasta que el rotor se pare completamente y esperar a que la temperatura superficial de la bomba sea inferior a 50°C.

En caso de avería se podrá utilizar el servicio de reparación Varian o el "Varian advanced exchange service", que permite obtener un sistema regenerado para sustituir el averiado.

NOTA

Antes de enviar al fabricante un sistema para su reparación o "advanced exchange service", es imprescindible cumplimentar y remitir a la oficina local de ventas la ficha de "Seguridad y Salud" adjunta al presente manual de instrucciones. Una copia de la misma se deberá introducir en el embalaje del sistema antes de enviarlo.

En caso de que el sistema se tenga que desguazar, eliminarlo respetando las normas nacionales específicas.

INFORMAÇÕES GERAIS

Esta aparelhagem destina-se a uso profissional. O utilizador deve ler atentamente o presente manual de instruções e todas as informações adicionais fornecidas pela Varian antes de utilizar a aparelhagem. A Varian não se responsabiliza pela inobservância total ou parcial das instruções, pelo uso indevido por parte de pessoas não treinadas, por operações não autorizadas ou pelo uso contrário às normas nacionais específicas.

O TV 551/701 Navigator é um sistema integrado, constituído por uma bomba turbomolecular para aplicações de alto e ultra-alto vácuo, integrada no relativo controller.

O sistema é capaz de bombear qualquer tipo de gás ou de composto gasoso, mas não é adequado para bombear líquidos ou partículas sólidas.

O efeito da bomba é obtido através de uma turbina rotativa de alta velocidade (42000 r.p.m. máx.) movida por um motor eléctrico trifásico de alto rendimento. O TV 551/701 Navigator é totalmente isentos de agentes contaminadores e, portanto, é adequado para aplicações que requerem um vácuo "limpo".

Além disso, o TV 551/701 Navigator tem conectores auxiliares através dos quais é possível alimentar um ventilador adicional, comandar a válvula de vent, accioná-lo por um controlo remoto através de um computer host conectado por meio de linhas seriais (RS 232/RS 485). Nos seguintes parágrafos estão descritas todas as informações necessárias para garantir a segurança do operador durante o uso da aparelhagem. Informações detalhadas são fornecidas no apêndice "Technical Information".

Este manual utiliza as seguintes convenções:



PERIGO!

As mensagens de perigo chamam a atenção do operador para um procedimento ou uma prática específica que, se não efectuada correctamente, pode provocar graves lesões pessoais.



ATENÇÃO!

As mensagens de atenção são visualizadas antes de procedimentos que, se não efectuados correctamente, podem causar danos à aparelhagem.

NOTA

As notas contêm informações importantes destacadas do texto.

ARMAZENAGEM

Durante o transporte e a armazenagem do TV 551/701 Navigator, devem ser respeitadas as seguintes condições ambientais

- temperatura: de -20°C a + 70°C
- humidade relativa: 0 - 95% (não condensante)

Se o tempo de armazenagem for muito longo, accionar a bomba em SOFT START.

PREPARAÇÃO PARA A INSTALAÇÃO

O TV 551/701 Navigator é fornecido numa embalagem protectora especial; se esta apresentar sinais de danos, que poderiam ter ocorrido durante o transporte, entrar em contacto com o escritório de vendas local.

Durante a remoção da embalagem, tomar muito cuidado para não deixar cair o controller e para não submetê-lo a choques ou vibrações.

Não depositar a embalagem no meio ambiente. O material é completamente reciclável e em conformidade com a norma CEE 85/399 para a protecção do meio ambiente.



ATENÇÃO!

Para evitar problemas de perdas de gás, não tocar com as mãos os componentes destinados à exposição do vácuo. Utilizar sempre luvas ou outra protecção adequada.

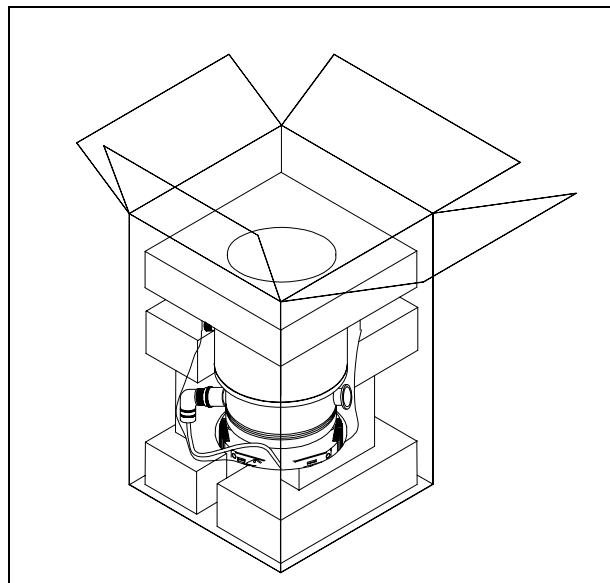

NOTA

O TV 551/701 Navigator não pode ser danificado permanecendo simplesmente exposto à atmosfera. Aconselha-se, no entanto, manter a bomba fechada até o momento da instalação no sistema para evitar eventuais acumulações de pó.

INSTALAÇÃO

Não instalar e/ou usar a bomba em ambientes expostos a agentes atmosféricos (chuva, gelo, neve), poeiras, gases agressivos, em ambientes com possibilidade de explosão ou com elevado risco de incêndio.

Durante o funcionamento é necessário que sejam respeitadas as seguintes condições ambientais:

- pressão máxima: 2 bar além da pressão atmosférica
- temperatura: de + 5°C a + 35°C (consultar a planilha no apêndice "Technical Information")
- humidade relativa: 0 - 95% (não condensante).

Na presença de campos electromagnéticos, a bomba deve ser protegida através de blindagens adequadas. Para ulteriores detalhes, consultar o apêndice "Technical Information".

O TV 551/701 Navigator deve ser ligado a uma bomba primária (consultar esquema em "Technical Information").

O TV 551/701 Navigator pode ser instalado em qualquer posição. Fixar o TV 551/701 Navigator em posição estável ligando o flange de entrada da turbobomba a um contra-flange fixo capaz de resistir a um torque de 4000 Nm ao redor do próprio eixo.

A turbobomba com flange de entrada ISO, deve ser fixada na câmara de vácuo através de bornes duplos ou simples. A tabela a seguir indica, para todas as dimensões do flange e todos os tipos de borne, o número de bornes e o torque de aperto necessários.

ATENÇÃO!

Remover a etiqueta autocolante e retirar a tampa de protecção somente no momento de ligar a turbobomba ao sistema.

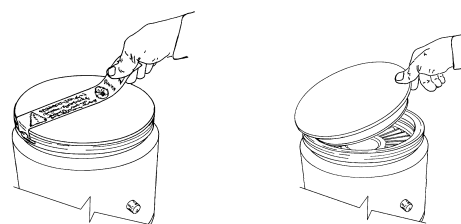

FLANGE	TIPO DE BORNE	N	TORQUE DE APERTO
ISO 100	Borne duplo com rosca M10	4	22 Nm
	Borne simples com rosca M8	8	11 Nm
ISO 160	Borne duplo com rosca M10	4	22 Nm
	Borne simples com rosca M10	8	22 Nm
ISO 200	Borne duplo com rosca M10	6	22 Nm
	Borne simples com rosca M10	12	22 Nm

A turbobomba com flange de entrada ConFlat deve ser fixada na câmara de vácuo através de parafusos específicos da mecânica Varian. Para posteriores detalhes, consultar o apêndice "Technical Information".

NOTA

O TV 551/701 não pode ser fixado através da sua base.

ATENÇÃO!

O TV 551/701 Navigator pertence à segunda categoria de instalação (ou sobretensão) prevista pela norma NE 61010-1. Portanto, ligue o dispositivo a uma linha de alimentação apropriada para esta categoria.

O TV 551/701 Navigator tem dois conectores para as entradas/saídas e para a comunicação de série que devem ser ligados aos circuitos externos de modo a não permitir o acesso às partes sob tensão. Assegure-se de que o isolamento do dispositivo ligado ao TV 551/701 Navigator esteja isolado correctamente mesmo em caso de avaria, conforme previsto pela norma NE 61010-1.

Para a instalação dos acessórios opcionais, consultar "Technical Information".

UTILIZAÇÃO

Neste parágrafo são descritos os principais procedimentos operacionais. Antes de usar o sistema, efectuar todas as ligações eléctricas e pneumáticas. Durante o eventual aquecimento da câmara a vácuo, a temperatura no flange de entrada não deve ser superior a 120 °C.

PERIGO!

Nunca activar a bomba se o flange de entrada não estiver ligado à câmara de vácuo ou não estiver fechado com o flange de fecho.

Não tocar a turbobomba e os seus eventuais acessórios durante as operações de aquecimento. A elevada temperatura pode causar lesões às pessoas.

ATENÇÃO!

Evitar colisões, oscilações ou deslocamentos bruscos da turbobomba quando está a funcionar. Os rolamentos poderiam sofrer danos.

Para a saída de ar da bomba utilizar ar ou gás inerte sem poeiras ou partículas. A pressão de entrada através da porta específica deve ser inferior a 2 bar (acima da pressão atmosférica).

Para bombear gases agressivos, estas bombas estão equipadas com uma porta específica através da qual é necessário fornecer à bomba um fluxo de gás inerte (Azoto ou Argon) para proteger os rolamentos (consultar o apêndice "Technical Information").



PERIGO!

Quando a bomba é utilizada para bombear gases tóxicos, inflamáveis ou radioactivos, seguir os procedimentos adequados típicos para cada gás. Não usar a bomba na presença de gases explosivos.

Acendimento e Utilização do TV 551/701

Navigator

Para ligar o TV 551/701 é suficiente fornecer a tensão de alimentação. O controller incorporado reconhece automaticamente os sinais de interlock e de activação, e acciona a bomba.

O primeiro accionamento da bomba faz-se em "Soft Star" que, no fim do ciclo de arranque, se desactiva automaticamente, portanto, todos os sucessivos arranques da bomba não serão em "Soft Start". Para poder arrancar a bomba em "Soft Start", será preciso reactivar o modo acima referido utilizando o software (consultar o parágrafo "RS 232 COMMUNICATION DESCRIPTION" no apêndice "Technical Information").

A luz piloto verde LD1, posicionada no painel da base do TV 551/701, indica, através da frequência de intermitência, as condições operacionais do sistema:

- acesa fixa: a bomba funciona normalmente;
- intermitência lenta (período de aprox. 400 ms): o sistema está em estado de aceleração, ou de paragem, ou de Stop, ou de "waiting for interlock".
- intermitência rápida (período de aprox. 200 ms): condição de erro.

Paragem do TV 551/701 Navigator

Para parar o TV 551/701 Navigator é suficiente desligar a tensão de alimentação. O controller incorporado para imediatamente a bomba.

Paragem de Emergência

Para parar o TV 551/701 Navigator em condições de emergência é necessário desligar, do controller, o cabo de alimentação.

MANUTENÇÃO

O TV 551/701 Navigator não requer qualquer manutenção. Todas as operações devem ser efectuadas por pessoal autorizado.



PERIGO!

Antes de executar qualquer operação no sistema, desligá-lo da alimentação, introduzir ar na bomba abrindo a válvula específica, aguardar até a completa paragem do rotor e até que a temperatura superficial da bomba seja inferior a 50 °C.

Em caso de defeito é possível usufruir do serviço de assistência Varian ou do "Varian advanced exchange service", que permite obter um sistema regenerado que substitua a bomba com defeito.

NOTA

Antes de reenviar ao fabricante um sistema para as reparações ou o "advanced exchange service", é indispensável preencher e enviar ao escritório de vendas local a ficha "Segurança e Saúde" anexa ao presente manual de instruções. A cópia da mesma deve ser colocada na embalagem do sistema antes da expedição.

Caso uma bomba deva ser destruída, proceder à sua eliminação respeitando as normas nacionais específicas.

ALGEMENE INFORMATIE

Deze apparatuur is bestemd voor beroepsmatig gebruik. De gebruiker wordt verzocht aandachtig deze handleiding en alle overige door Varian verstrekte informatie door te lezen alvorens het apparaat in gebruik te nemen. Varian acht zich niet aansprakelijk voor de gevolgen van het niet of gedeeltelijk in acht nemen van de aanwijzingen, onoordeelkundig gebruik door niet hiervoor opgeleid personeel, reparaties waarvoor geen toestemming is verkregen of gebruik in strijd met de specifieke nationale wetgeving.

De TV551/701 Navigator is een geïntegreerd systeem dat uit een turbomoleculaire pomp voor hoge en ultrahoge vacuümtoepassingen plus bijbehorende controller bestaat. Het systeem is in staat om elk type gas of gasverbinding te pompen, maar is niet geschikt voor het pompen van vloeistoffen of vaste deeltjes. Het pompeffect wordt verkregen door een zeer snel draaiende turbine (max. 42.000 toeren/min.) die aangedreven wordt door een elektrische draaistroommotor met hoog rendement. De TV 551/701 Navigator is volledig vrij van verontreinigingen en is dus ook geschikt voor toepassingen die een "schoon" vacuüm verlangen.

De TV 551/701 Navigator is bovendien van hulpconnectors voorzien waarmee een extra ventilator kan worden gevoed, de luchtuitlaatkleppen kunnen worden aangestuurd, en waarmee het systeem d.m.v. een serieel aangesloten host computer op afstand kan worden bediend (RS 232/RS 485).

In de volgende paragrafen is alle informatie vermeld om de veiligheid van de operator tijdens het gebruik van de apparatuur te verzekeren. Gedetailleerde informatie is te vinden in de bijlage "Technical information".

Deze handleiding maakt van de volgende symbolen gebruik:



GEVAAR!

Bij dit symbool staat tekst die de aandacht van de operator vestigt op een speciale procedure of methode die, indien niet correct uitgevoerd, ernstig lichamelijk letsel kan veroorzaken.



ATTENTIE!

Bij dit symbool staat tekst met procedures die, indien niet opgevolgd, schade aan apparatuur kunnen veroorzaken.

OPMERKING

De opmerkingen bevatten belangrijke informatie die uit de tekst is gelicht.

OPSLAG

Tijdens het transport en de opslag van de TV 551/701 Navigator moeten de volgende omgevingscondities aanwezig zijn:

- temperatuur: van -20°C tot +70°C
- relatieve vochtigheid: 0 - 95% (niet condenserend)

Als de opslagperiode van lange duur is, de pomp met de SOFT START wijze opstarten

UITPAKKEN

De TV 551/701 Navigator wordt in een speciale beschermende verpakking geleverd; als er schade wordt geconstateerd die tijdens het transport veroorzaakt zou kunnen zijn, meteen contact opnemen met het plaatselijke verkoopkantoor.

Zorg er bij het uitpakken voor dat de TV 551/701 Navigator niet kan vallen en geen stoten of trillingen te verduren krijgt.

Laat de verpakking niet ergens buiten achter. Het verpakkingsmateriaal is volledig recyclebaar en voldoet aan de EEG milieurechtlijn 85/399.



ATTENTIE!

Om ontgassingsproblemen te voorkomen, mogen de componenten die met het vacuüm in aanraking komen niet met de blote handen aangeraakt worden. Gebruik altijd handschoenen of een andere geschikte bescherming.

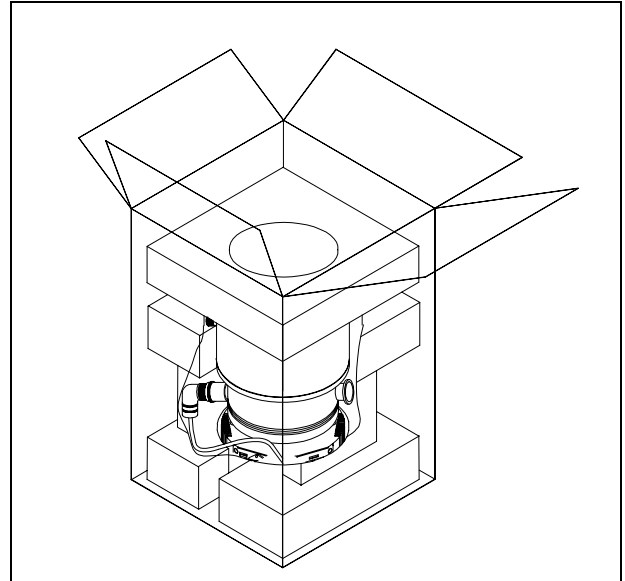

OPMERKING

De TV 551/701 Navigator kan niet beschadigd worden door eenvoudigweg aan de atmosfeer blootgesteld te worden. Toch wordt aangeraden om de pomp gesloten te houden zolang deze niet in het systeem wordt ingebouwd, zodat eventuele vervuiling door stof wordt voorkomen.

INSTALLATIE

De pomp mag niet geïnstalleerd en/of gebruikt worden in ruimten die blootgesteld zijn aan de weersomstandigheden (regen, vorst, sneeuw), stof, agressieve gassen, of in ruimten met explosiegevaar of zeer groot brandgevaar.

Tijdens de werking moeten de volgende omgevingscondities aanwezig zijn

- max. druk: 2 bar boven de atmosferische druk
- temperatuur: van +5°C tot +35°C (zie grafiek in de bijlage "Technical Information")
- relatieve vochtigheid: 0 - 95% (niet condenserend).

In aanwezigheid van magnetische velden moet de pomp op passende wijze afgeschermd worden. Zie de bijlage "Technical Information" voor meer informatie.

De TV 551/701 Navigator moet op een primaire pomp aangesloten zijn (zie schema in "Technical information").

De TV 551/701 Navigator kan in alle standen worden geïnstalleerd. Bevestig de TV 551/701 Navigator in een stabiele positie en verbind de inlaatflens van de turbopomp met een vaste contraflens die een koppel van 4000 Nm rondom de eigen as kan verdragen. De turbopomp met ISO inlaatflens moet aan de vacuümkamer worden verbonden met behulp van dubbele of enkelvoudige klemmen. De volgende tabel beschrijft, voor elke maat flens of klemtipe, het aantal benodigde klemmen en het aanhaalkoppel waarmee ze vastgezet moeten worden.



ATTENTIE!

Alleen op het moment waarop de turbopomp op het systeem wordt aangesloten mogen de sticker en de beschermdop verwijderd worden.

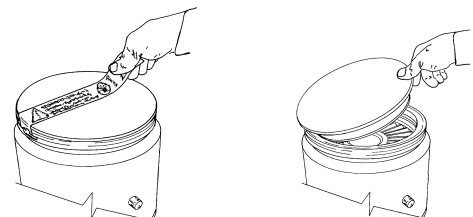

FLENS	KLEMTYPE	NR.	AANHAAL KOPPEL
ISO 100	Dubbele klem met M10 schroefdraad	4	22 Nm
	Enkelvoudige klem met M8 schroefdraad	8	11 Nm
ISO 160	Dubbele klem met M10 schroefdraad	4	22 Nm
	Enkelvoudige klem met M10 schroefdraad	8	22 Nm
ISO 200	Dubbele klem met M10 schroefdraad	6	22 Nm
	Enkelvoudige klem met M10 schroefdraad	12	22 Nm

De turbopomp met ConFlat inlaatflens moet aan de vacuumpomp worden bevestigd met behulp van de speciale mechanische bevestigingselementen van Varian. Zie voor meer informatie de bijlage "Technical information".

OPMERKING

De TV551/701 Navigator kan niet met behulp van zijn eigen basis worden bevestigd.

 **ATTENTIE!**

De TV 551/701 Navigator behoort tot de tweede installatiecategorie (of overspanningscategorie) die door de norm EN 61010-1 is voorzien. Sluit deze inrichting dus aan op een voedingslijn die aan deze categorie voldoet.

De TV 551/701 Navigator bezit connectoren voor de ingangen/uitgangen en voor de seriële communicatie die aangesloten moeten worden op de externe circuits, zodat geen enkel deel onder spanning toegankelijk is. Controleer of de inrichting verbonden met de TV 551/701 Navigator goed geïsoleerd is, ook in geval van een enkele storing zoals voorzien door de norm EN 61010-1.

Zie "Technical Information" voor installatie van accessoires die als optie verkrijgbaar zijn.

GEBRUIK

In deze paragraaf worden de belangrijkste gebruikspedures vermeld. Breng alle elektrische en pneumatische aansluitingen tot stand alvorens het systeem te gebruiken. Tijdens de eventuele verwarming van de vacuümkamer mag de temperatuur op de inlaatflens niet meer dan 120° C bedragen.

 **GEVAAR!**

Laat de pomp nooit draaien als de inlaatflens niet op de vacuümkamer is aangesloten of als de afsluitflens niet gesloten is. Raak de turbopomp en eventuele accessoires niet tijdens het verwarmen aan. De hoge temperatuur kan lichamelijk letsel veroorzaken.

 **ATTENTIE!**

Vermijd schokken, trillingen of bruske verplaatsingen van de turbopomp wanneer deze in werking is. De lagers kunnen anders beschadigd raken.

Gebruik voor de luchttoevoer naar de pomp lucht of inert gas zonder stof of vaste deeltjes. De inlaatdruk via de hiervoor bestemde poort moet minder dan 2 bar (boven de atmosferische druk) bedragen.

Deze pompen zijn voor het pompen van agressieve gassen van een speciale poort voorzien, waardoor de pomp een stroom inert gas (stikstof of argon) ter bescherming van de lagers krijgt geleverd (zie bijlage "Technical Information").

 **GEVAAR!**

Wanneer de pomp wordt gebruikt voor het pompen van brandbare, giftige of radioactieve gassen, moeten de procedures worden gevolgd die speciaal voor elk type gas zijn opgesteld. Gebruik de pomp niet in aanwezigheid van explosieve gassen.

Inschakeling en gebruik van de TV 551/701 Navigator

Om de TV551/701 Navigator in te schakelen is het voldoende om deze van stroom te voorzien. De ingebouwde controller herkent automatisch de aanwezigheid van interlock- en startsignalen en start de pomp.

De eerste start van de pomp geschiedt op de wijze "Soft Start" die, aan het einde van de startcyclus, automatisch ontmachtigd wordt. Vandaar dat alle volgende starts niet op de wijze "Soft Start" geschieden. Om opnieuw met "Soft Start" te starten, moet bovengenoemde wijze met behulp van de software gemachtigd worden (zie paragraaf "RS 232 COMMUNICATION DESCRIPTION" in de bijlage "Technical Information").

De groene LED LD1 op het paneel van de basis van de TV 551/701 geeft door de frequentie van zijn knipperen, de werkcondities van het systeem aan:

- brandt onafgebroken: de pomp draait normaal;
- knippert langzaam (periode van circa 400 ms): het systeem is in de status "oploop" of "remmen" of "stop" of "waiting for interlock";
- knippert snel (periode van circa 200 ms): fouttoestand.

Afzetten van de TV 551/701 Navigator

Hiervoor behoeft slechts de stroomvoorziening te worden onderbroken. De ingebouwde controller stopt onmiddellijk de pomp.

Noodstop

Om de TV 551/701 Navigator in noodomstandigheden te stoppen, moet de stroomtoevoerkabel van de controller losgemaakt worden.

ONDERHOUD

De TV 551/701 Navigator is onderhoudsvrij. Eventuele werkzaamheden moeten door bevoegd personeel worden uitgevoerd.

 **GEVAAR!**

Alvorens werkzaamheden aan het systeem uit te voeren, de stekker verwijderen, de pomp met behulp van de hiervoor bestemde klep ontluichten en wachten totdat de rotor volledig stil staat en de oppervlaktetemperatuur van de pomp onder een temperatuur van 50 °C is gezakt.

In geval van storing is het mogelijk om de reparatiedienst van Varian of de "Varian advanced exchange service" in te schakelen: zo krijgt men een ruilpomp ter vervanging van de defecte pomp.

OPMERKING

Alvorens de pomp ter reparatie of ruil naar de fabrikant op te sturen, moet de bij deze handleiding gevoegde kaart "Veiligheid en Gezondheid" volledig ingevuld naar het plaatselijke verkoopkantoor worden gestuurd. Een kopie van deze kaart moet vóór versturing bij de pomp in de verpakking worden gevoegd.

Mocht het systeem gesloopt worden, ga dan overeenkomstig de specifieke nationale wetgeving te werk.

GENEREL INFORMATION

Dette udstyr er beregnet til professionel anvendelse. Brugeren bør læse denne brugsanvisning og anden yderligere information fra Varian, før udstyret anvendes. Varian tager ikke ansvar for skader helt eller delvis som følge af tilsidesættelse af disse instruktioner, fejlagtig brug af personer uden tilstrækkeligt kendskab, ukorrekt anvendelse af udstyret eller håndtering, der strider imod gældende lokale regler.

TV 551/701 Navigator-systemet omfatter en turbomolekylær pumpe til høje eller meget høje vakuumtilpasninger og aktuel styreenhed. Systemet er i stand til at pumpe en hvilken som helst form for gas eller gaslignende luftarter, men systemet kan ikke anvendes til pumpning af væske eller af faste partikler.

Pumpningen sker ved hjælp af en hurtigroterende turbine (42000 omdr./min.). Turbinen drives af en elektrisk trefasemotor med høj effekt. TV 551/701 Navigator er ikke fremstillet af skadelige stoffer og er derfor egnet til anvendelse, der kræver "rent" vakuum.

TV 551/701 Navigator har endvidere hjælpestik, der gør det muligt at forsyne ventilator, styre ventilationsventilen og fjernstyre den ved hjælp af en værtscomputer gennem seriel forbindelse (RS 232/RS 485).

De følgende afsnit indeholder oplysningerne, der er nødvendige for at garantere sikkerhed for operatøren i forbindelse med anvendelse af udstyret. Bilaget "Teknisk Information" indeholder detaljerede oplysninger.

I brugsanvisningen anvendes følgende standardrubrikker:



ADVARSEL!

Advarselsmeddelelserne informerer operatøren om, at en speciel procedure eller en vis type arbejde skal udføres præcist efter anvisningerne. I modsat fald er der risiko for svære personskader.



VIGTIGT!

Denne advarselsmeddelelse vises før procedurer, der skal følges nøje for ikke at risikere maskinskader.

BEMÆRK

Dette gør opmærksom på vigtig information i teksten.

OPBEVARING

Følgende krav til omgivelsesforholdene gælder ved transport og opbevaring af TV 551/701 Navigator :

- temperatur: fra -20 °C til +70 °C
- relativ luftfugtighed: 0 - 95% (ikke kondenserende)

Efter lang tids opbevaring skal udstyret startes ved hjælp SOFT START metoden.

FORBEREDELSE FØR INSTALLATION

TV 551/701 Navigator leveres i en speciel beskyttende emballage. Kontakt den lokale forhandler, hvis emballagen viser tegn på skader, der kan være opstået under transporten.

Sørg for, at TV 551/701 Navigator ikke tabes eller udsættes for stød ved udpakningen.

Smid ikke emballagen ud. Materialet kan genbruges 100% og opfylder EU-direktiv 85/399 om miljøbeskyttelse.



VIGTIGT!

Komponenter, der skal udsættes for vakuum, må ikke berøres med bare hænder, idet der er risiko for afgang. Anvend altid handsker eller anden lignende beskyttelse.

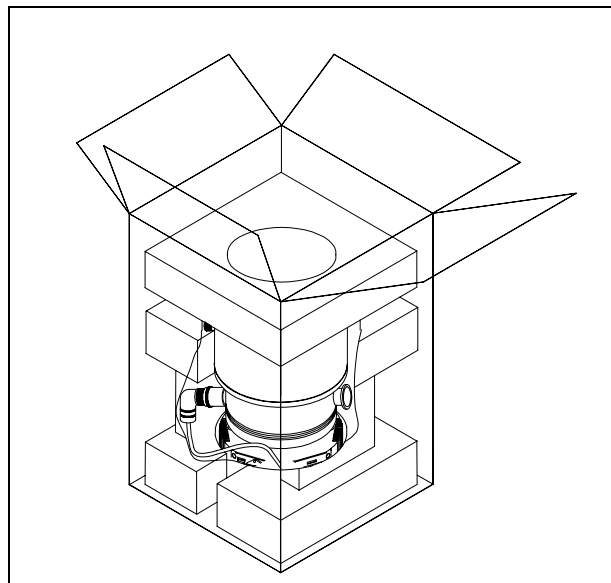

BEMÆRK

Normal atmosfærisk påvirkning kan ikke skade TV 551/701 Navigator. Det anbefales dog, at opbevare pumpen i en lukket kasse, indtil den skal installeres. Herved forhindres, at der kommer støv i pumpen.

INSTALLATION

Installér og anvend ikke pumpen i miljøer, der udsættes for påvirkninger fra atmosfæren (regn, sne, is), damp, aggressive gasser, og ligeledes ikke i eksplosivt eller brandfarligt miljø.

Følgende krav til omgivelsesforholdene gælder ved drift:

- max. tryk: 2 bar over det atmosfæriske tryk
- temperatur: fra +5°C til +35°C (se illustrationen i bilaget "Teknisk Information")
- relativ luftfugtighed: 0 - 95% (ikke kondenserende)

Hvis pumpen er anbragt i nærheden af elektromagnetiske felter, skal den afskærmes. Se bilaget "Teknisk Information" for yderligere oplysninger.

TV 551/701 Navigator skal tilsluttes en hovedpumpe (se skemaet "Teknisk Information").

TV 551/701 Navigator kan installeres i en hvilken som helst position. Fastgør TV 551/701 Navigator i en stabil position ved at slutte turbopumpens indløbsflange til en fast kontraflange, der tåler et moment på 4000 Nm omkring akselen. Turbopumpen med ISO-indløbsflange skal tilsluttes vakuumkammeret ved hjælp af dobbelte eller enkelte klemmer. Den nedenstående tabel viser det nødvendige antal af klemmer samt drejningsmoment afhængig af flangens størrelse og klemmetypen.



VIGTIGT!

Tapen og beskyttelsesproppen fjernes først, når turbopumpen tilsluttes systemet.

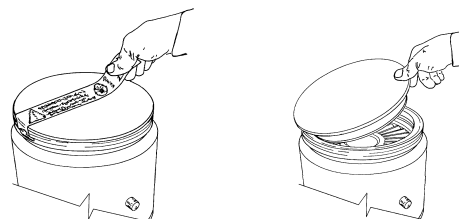

LANGE	KLEMMETYPE	ANT.	DREJNINGSMOMENT
ISO 100	Dobbelt klemme med M10 gevind	4	22 Nm
	Enkelt klemme med M8 gevind	8	11 Nm
ISO 160	Dobbelt klemme med M10 gevind	4	22 Nm
	Enkelt klemme med M10 gevind	8	22 Nm
ISO 200	Dobbelt klemme med M10 gevind	6	22 Nm
	Enkelt klemme med M10 gevind	12	22 Nm

Turbopumpen med ConFlat indløbsflange skal tilsluttes på vakuumkammeret ved hjælp af Varian monteringsudstyret. I bilaget "Teknisk Information" findes yderligere detaljer.

BEMÆRK

Navigator TV 551/701 kan ikke fastgøres i fundamentet.

VIGTIGT!

TV 551/701 Navigator hører til den anden installationsklasse (eller overspændingsklasse) jf. normen EN 61010-1. Slut derfor anordningen til en forsyningslinie, som opfylder kravene i denne klasse.

TV 551/701 Navigator er forsynet med konnektorer til ind-/udgange og til seriel kommunikation. Konnektorerne skal tilsluttes de eksterne kredsløb, således at det ikke er muligt at opnå adgang til de spændingsførende dele. Kontrollér, at anordningen, der er tilsluttet TV 551/701 Navigator, har en passende isolering. Dette gælder også i tilfælde af enkeltfejl som angivet i normen EN 61010-1.

Der henvises til bilaget "Teknisk Information" for oplysninger vedrørende installation af ekstraudstyret.

ANVENDELSE

Dette afsnit beskriver de vigtigste driftsprocedurer. Inden anvendelse af systemet, bør samtlige elektriske og pneumatiske tilslutninger udføres. I forbindelse med opvarmning af vakuumkammeret må indløbsflangens temperatur ikke overstige 120° C.

ADVARSEL!

Pumpen må aldrig aktiveres, hvis indløbsflangen ikke er tilsluttet vakuumkammeret, eller hvis pumpen ikke er lukket ved hjælp af lukkeflangen.

Rør aldrig turbopumpen eller dens tilbehør i forbindelse med opvarmningsprocedurerne. Den høje temperatur kan resultere i skade på personer.

VIGTIGT!

Undgå sammenstød, vibrationer eller bratte bevægelser i forbindelse med brug af turbopumpen. Der er risiko for beskadigelse af lejerne.

Pumpen skal forsynes med luft eller ædelgasser, der ikke indeholder støv eller faste partikler. Indgangstrykket ved den specielle dør skal være mindre end 2 bar (over atmosfærisk tryk). I forbindelse med pumpning af aggressive gasser er disse pumper udstyret med en dør, igennem hvilken det er nødvendigt at forsyne pumpen med ædelgasser (kvælstof eller argon) for at beskytte lejerne (se bilaget "Teknisk Information").

ADVARSEL!

Når pumpen anvendes til toksiske, brandfarlige eller radioaktive gasser, følges fremgangsmåden for den enkelte gastype.

Anvend ikke pumpen til eksplosive gasser.

Start og anvendelse af TV 551/701 Navigator

For at starte TV 551/701 er det tilstrækkeligt at tilslutte et forsyningsstik. Den indbyggede styreenhed genkender blokerings- og startsignaler automatisk, og starter pumpen.

Pumpen startes første gang ved hjælp af SOFT START metoden. Når startprocessen er afsluttet, frakobles denne funktion automatisk med hensyn til alle efterfølgende aktiveringer af pumpen, der vil ske uden SOFT START metoden.

For at aktivere SOFT START metoden på ny skal ovennævnte måde programmeres ved hjælp af software (se afsnit "RS 232 COMMUNICATION DESCRIPTION" i bilaget "Teknisk Information").

Den grønne LED LD1, der er anbragt på panelet på TV 551/701's fundament, angiver systemets funktion ved blink:

- konstant tændt: pumpen er i normal rotation
- langsomme blink: (periode på ca. 400 ms); systemet er i stilling for acceleration, bremsing, stop eller "Waiting for interlock"
- hurtige blink: (periode på ca. 200 ms); fejl.

Stop af TV 551/701 Navigator

For at afbryde TV 551/701 Navigator er det tilstrækkeligt at afbryde strømtilførselen. Den indbyggede styreenhed afbryder straks pumpen.

Nødstop

Afbrydelse af TV 551/701 Navigator i nødsituationer sker ved at koble ledningen fra styreenheden.

VEDLIGEHODELSE

TV 551/701 Navigator behøver ikke nogen vedligeholdelse. Ethvert indgreb skal foretages af autoriseret personale.

ADVARSEL!

Inden der foretages noget som helst indgreb på systemet, skal strømmen først afbrydes, og luften i pumpen skal fjernes ved at åbne ventilen. Vent med foretagelse af indgrebet til rotoren er standset, og til temperaturen på pumpens overflade er under 50°C.

I tilfælde af skader på systemet kontaktes et Varian reparationsværksted eller "Varian advanced exchange service", der udskifter systemet med et repareret system.

BEMÆRK

Inden systemet sendes til reparationsværkstedet eller "Varian advanced exchange service" skal "Sikkerheds- og tilstandsdocumentet", der er vedlagt denne instruktionsmanual, udfyldes. En kopi af dette dokument skal indsættes i systemets emballage inden afsendelse.

Skrotning af systemet skal foregå i overensstemmelse med det pågældende lands særlige love.

ALLMÄN INFORMATION

Utrustningen är avsedd för yrkesmässig användning. Användaren bör läsa denna bruksanvisning, samt övrig dokumentation från Varian före användning av utrustningen. Varian tar inget ansvar för skador helt eller delvis till följd av åsidosättande av instruktionerna, olämplig användning av person utan tillräcklig kunskap, obehörigt bruk av utrustningen eller hantering som strider mot gällande lokala föreskrifter.

Systemet TV 551/701 Navigator består av en turbomolekylär pump för höga och mycket höga vakuumtillämpningar och en styrenhet. Systemet kan användas för pumpning av alla typer av gas eller gasföreningar. Dock lämpar sig inte systemet för pumpning av vätskor eller fasta partiklar.

Pumpningen åstadkoms med hjälp av en högvarv turbin (max 42000 varv/minut) som drivs av en trefas hög effektmotor. Inga tillsatssämnen används i TV 551/701 Navigator, som därför passar för tillämpningar som kräver ett "rent" vakuum.

TV 551/701 Navigator har dessutom en hjälpkontakt som gör det möjligt att förse ström till en extra ventilator, att kontrollera avluftningsventilen, och att fjärrstyra den med hjälp av en hostdator som är ansluten genom seriell förbindelse (RS 232/RS 485).

De följande avsnitten innehåller all information som behövs för att garantera operatörens säkerhet under användningen. Detaljerade uppgifter finns i bilagan "Technical information".

I bruksanvisningen används följande standardrubriker:



! VARNING!

Varningsmeddelandena informerar operatören om att en speciell procedur eller en viss typ av arbete måste utföras exakt enligt anvisningarna. I annat fall finns risk för svåra personskador.



VIKTIGT !

Detta varningsmeddelande visas framför procedurer som måste följas exakt för att inte risk för maskinskada skall uppstå.

OBSERVERA

Detta visar på viktig information i texten.

FÖRVARING

Följande krav på omgivningsförhållanden gäller vid transport och förvaring av TV 551/701 Navigator:

- temperatur: från -20°C till +70°C
- relativ luftfuktighet: 0 - 95% (utan kondens)

Efter lång förvaring skall pumpen startas med MJUKSTART - metoden.

FÖRBEREDELSE FÖR INSTALLATIONEN

TV 551/701 Navigator levereras i ett särskilt skyddande emballage. Kontakta det lokala försäljningskontoret om emballaget visar tecken på skador som kan ha uppstått under transporten. Se till att TV 551/701 Navigator inte tappas eller utsätts för stötar vid upppackningen.

Kasta inte packmaterialet i soporna. Materialet är återvinningsbart till 100% och uppfyller EU-direktiv 85/399 om miljöskydd.



VIKTIGT !

Komponenter som skall utsättas för vakuum får inte hanteras med bara händer p g a kontamineringsrisken. Använd alltid handskar eller liknande skydd.

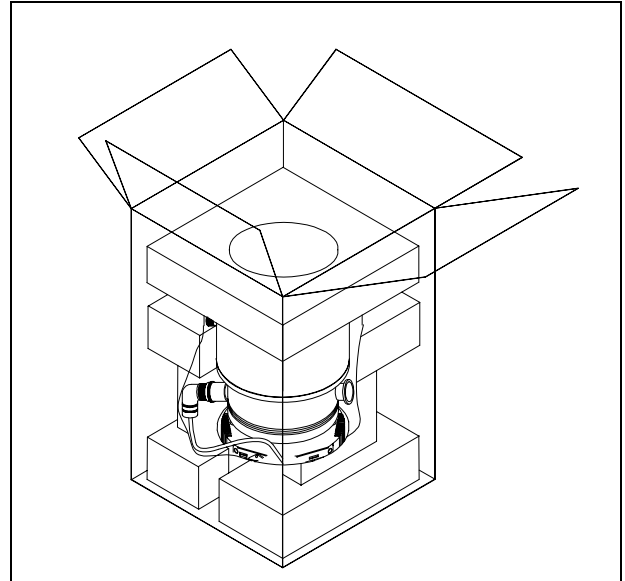

OBSERVERA

Normal påverkan från omgivningen kan inte skada TV 551/701 Navigator. Trots det är det säkrast att hålla pumpen nerpackad tills den har installerats i systemet, för att förhindra att det kommer in damm eller annat i den.

INSTALLATION

Installera och använd inte pumpen i miljöer som utsätts för påverkan från atmosfären (regn, snö, is), damm, aggressiva gaser, och inte heller i explosiv eller brandfarlig miljö.

Följande krav på omgivningsförhållanden gäller vid drift:

- maximitryck: 2 bar (över atmosfäriskt tryck)
- temperatur: från +5°C till +35°C (se bild i "Technical Information")
- relativ luftfuktighet: 0 - 95% (utan kondens).

I närvaro av magnetfält ska pumpen skyddas med en särskild skärm. Se bilagan "Technical information" för ytterligare upplysningar. TV 551/701 Navigator måste anslutas till en huvudpump (se schemat i "Technical information").

TV 551/701 Navigator kan installeras i valfri position. Fäst pumpen i ett stabilt läge genom att ansluta pumpens intagsfläns till en fast fläns som måste tåla ett vridmoment på 4000 Nm kring sin axel.

VIKTIGT !

Ta bort tejpens och skyddsproppens först när turbopumpen ska anslutas till systemet.

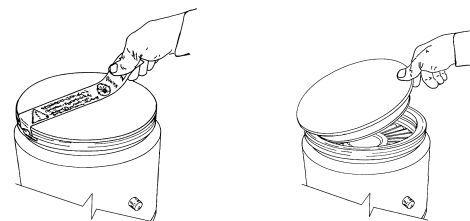

Turbopumpen med ISO-intagsfläns ska fästas i vakuumkammaren med hjälp av dubbla eller enkla klamrar. Den följande tabellen beskriver olika flänsstorlekar, olika typer av klamrar, nödvändigt antal klamrar och åtdragningsmoment.

FLÄNS	TYP AV KLAMMER	ANT.	ÅTDRAGNINGSMOMENT
ISO 100	Dubbel klammer, gänga M10	4	22 Nm
	Enkel klammer, gänga M8	8	11 Nm
ISO 160	Dubbel klammer, gänga M10	4	22 Nm
	Enkel klammer, gänga M10	8	22 Nm
ISO 200	Dubbel klammer, gänga M10	6	22 Nm
	Enkel klammer, gänga M10	12	22 Nm

Turbopumparna med intagsfläns ConFlat ska fästas till vakuumkammaren med hjälp av Varian fästdelar. För detaljer hänvisas till bilaga "Technical Information"

OBSERVERA

TV 551/701 Navigator-systemet kan inte fastspännas med sin egen bas.

VIKTIGT !

TV 551/701 Navigator tillhör den andra installationsklassen (eller överspänningsklassen) enligt standard EN 61010-1. Anslut därför anordningen till en elledning som uppfyller kraven för denna klass.

TV 551/701 Navigator är utrustad med kontaktdon för ingångarna/utgångarna och för den seriella kommunikationen som ska anslutas till de externa kretsarna så att det inte går att komma åt någon spänningsförande del. Kontrollera att anordningen som är ansluten till TV 551/701 Navigator har en lämplig isolering även vid ett enskilt fel enligt standard EN 61010-1.

Installation av tillbehörsutrustning beskrivs i "Technical Information".

ANVÄNDNING

Anvisningar för riktig användning finns i styrenhetens bruksanvisning.

Innan du använder systemet ska du utföra alla elektriska och pneumatiska anslutningar. Om vakuumkammaren uppvärms får temperaturen vid inloppet aldrig överstiga 120°C.



VARNING!

Sätt aldrig igång pumpen om intagsflänsen varken är kopplad till vakuumkammaren eller är blockerad på plats med läsflänsen.

Vidrör inte turbopumpen eller några tillbehör under uppvärmningen för att undvika brännskador.

VIKTIGT!

Undvik sammanstötningar, svängningar eller plötsliga förflyttningar av turbopumpen när den är igång. Lagren kan bli skadade.

Pumpen ska förses med luft eller med ädelgaser som ärfria från damn eller andra partiklar. Ingångstrycket mot rätt dörr måste understiga 2 bar (utöver det atmosfäriska trycket).

För pumpning av frätande gaser är dessa pumpar försedda med en speciell öppning igenom vilken man ska leda en ström av ädelgas (kväve eller argon) för att skydda lagren (se bilagan "Technical information").



VARNING!

Då pumpen används för pumpning av giftiga, lättantändliga eller radioaktiva gaser, bör man följa de särskilda anvisningarna för varje enskild gas.

Använd ej pumpen i närheten av explosiva gaser.

Start och användning av TV 551/701 Navigator

För att starta TV 551/701 behöver du bara ansluta till ett eluttag. Den inbyggda styrenheten känner automatiskt igen förreglings- och startsignaler, och startar pumpen.

Pumpens första start sker i "Mjukstart"-läget som i slutet av inledningscykeln slås av automatiskt. Därefter sker pumpens inledningar utan funktionen "Mjukstart". För att återaktivera "Mjukstart" måste man återställa ovannämnda läge genom mjukvaran (se stycket "RS 232 COMMUNICATION DESCRIPTION" i bilagan "Technical information").

Den gröna lysdioden LD1 på underdelen av TV 551/701 anger, genom frekvensen av dess blinkningar, hur systemet fungerar:

- fast sken: pumpen roterar normalt;
- långsamt blinkande (ungefär var 400 ms) : systemet är i läge för acceleration, bromsning, Stop eller "Waiting for interlock";
- hastigt blinkande (ungefär 200 ms) : feltillstånd.

Att stänga av TV 551/701 Navigator

Om du vill stänga av TV 551/701 Navigator behöver du bara dra ut elkabeln ur vägguttaget. Den inbyggda styrenheten avbryter omedelbart pumpens funktion.

Nödstopp

Dra ut elsladden från styrenheten för att utföra ett nödstopp av TV 551/701 Navigator.

UNDERHÅLL

TV 551/701 Navigator är underhållsfritt. Allt servicearbete måste utföras av auktoriserad personal.



VARNING!

Innan något arbete utförs på systemet måste pumpens strömförsörjning avbrytas och pumpen luftas genom att den aktuella ventilen öppnas. Vänta sedan tills rotorn stannat samt tills pumpens yttemperatur är lägre än 50°C.

Om pumpen havererar, kontakta Varian reparationsverkstad eller Varian utbytesservice, som kan ersätta systemet med ett renoverat system.

OBSERVERA

Innan systemet lämnas in till tillverkaren för reparation eller utbyte mot en renoverad enhet, måste "hälsa- och säkerhetsbladet" som medföljer bruksanvisningen fyllas i och skickas in till den lokala återförsäljaren. Bifoga dessutom en kopia av bladet med pumpen.

Skrotning av pumpen skall ske enligt gällande lagstiftning.

GENERELL INFORMASJON

Dette utstyret er beregnet til bruk av profesjonelle brukere. Brukeren bør lese denne brukerveiledningen og all annen informasjon fra Varian før utstyret tas i bruk. Varian kan ikke holdes ansvarlig for hendelser som skjer på grunn av manglende oppfølging av disse instruksjonene, selv delvis, feilaktig bruk av utrent personell, ikke autoriserte endringer av utstyret eller handlinger som på noen måte er i strid med nasjonale bestemmelser.

TV 551/701 Navigator systemet består av en turbo-molekylær pumpe for bruk i høy- eller ultrahøye vakuumanlegg og en styreenhet. Systemet kan pumpe nesten alle typer gass eller gassforening. Det er ikke beregnet for å pumpe væsker eller faste partikler.

Pumpingen oppnås med en høyhastighetsturbin (maks. 42000 opm) koplet til en trefaset elektrisk motor. TV 551/701 Navigator har ingen forurensende stoffer og er derfor egnet for anlegg med behov for "rene" vakuum.

TV 551/701 Navigator har dessuten hjelpekontakter som gir muligheter for forsyning av en ekstra vifte, styring av utluftingsventilen, og fjernstyring av systemet med en serietilkoplet vertsmaskin.

De følgende avsnitt inneholder all informasjon som er nødvendig for å sikre brukeren når utstyret er i bruk. For mer detaljert bruk vises det til tillegget "Teknisk informasjon".

Denne manualen bruker følgende standardprotokoll :



ADVARSEL!

Disse meldingene skal tiltrekke seg brukerens oppmerksomhet til en spesiell fremgangsmåte eller praksis som, hvis den ikke følges, kan medføre alvorlige skader.



FORSIKTIG!

Denne advarselen vises foran fremgangsmåter som, dersom de ikke følges, kan føre til at utstyret skades.

MERK

Merknadene inneholder viktig informasjon som er hentet fra teksten.

LAGRING

Når TV 551/701 Navigator transporteres eller lagres, må følgende miljømessige krav oppfylles:

- temperatur: fra -20°C til +70°C
- relativ fuktighet: 0 - 95% (uten kondens)

Skal utstyret lagres lengre, må pumpen MYKSTARTES (se styreenhetens manual).

KLARGJØRE TIL INSTALLASJON

TV 551/701 Navigator leveres i en spesiell beskyttelsesemballasje. Viser denne tegn på skader som kan ha oppstått under transporten, må du ta kontakt med det lokale salgskontoret.

Når TV 551/701 Navigator pakkes ut, må du se til at det ikke slippes ned eller utsettes for noen form for støt.

Emballasjen må ikke kastes på en ulovlig måte. Alle materialer er 100% resirkulerbare og er i samsvar med EU-direktiv 85/399 om miljøbeskyttelse.



FORSIKTIG!

For å unngå avgassingsproblemer, må ingen del som skal utsettes for vakuum håndteres med bare hendene. Bruk alltid hansker eller andre og passende verneutstyr.

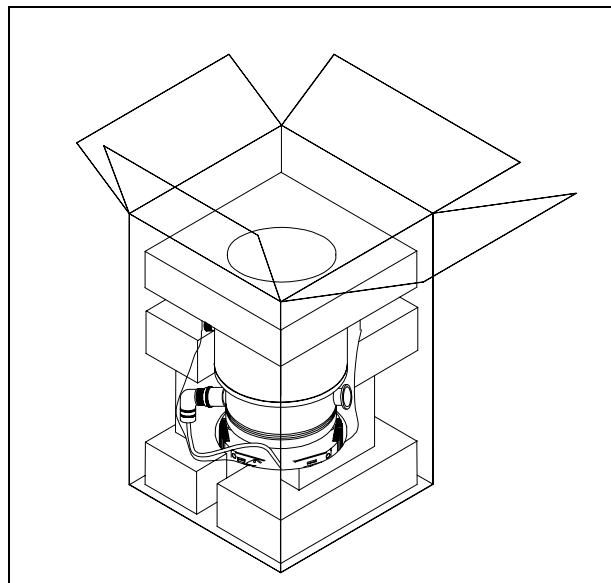

MERK

Normale miljømessige belastninger kan ikke ødelegge TV 551/701 Navigator. Likevel anbefaler vi å holde pumpen lukket til den er montert i systemet, slik at den ikke forurenses eller utsettes for nedstøving.

INSTALLASJON

Ikke installer eller bruk systemet i miljøer som utsettes for regn, snø eller is, støv, aggressive gasser, eksplosjonsfarlige miljøer eller miljøer med stor brannfare.

Under bruk må følgende forhold respekteres:

- maksimalt trykk: 2 bar (over atmosfærisk trykk)
- temperatur: fra +5°C til +35°C (se diagram i tillegget "Teknisk informasjon")
- relativ fuktighet: 0 - 95% (uten kondens)

Ved magnetfelt må pumpen beskyttes av dertil egnede skjermer. Se "Teknisk informasjon" for detaljer.

TV 551/701 Navigator må koples til en hovedpumpe (se skjema i "Teknisk informasjon").

TV 551/701 Navigator kan monteres i en valgfri stilling. Fest TV 551/701 Navigator i en stabil stilling med inngangsslensen festet mot en fast koplingsflens med et dreiemoment på 4000 Nm rundt akselen. Turbopumpene med ISO innløpsflens skal festes til vakuumkammeret med doble eller enkle klemmer.

Følgende tabell angir det nødvendige antall klemmer og det relevante strammemomentet for de enkelte flensdimensjonene og typer klemmer.



FORSIKTIG!

Tapen og beskyttelsesproppen skal fjernes først når turbopumpen koples til systemet.

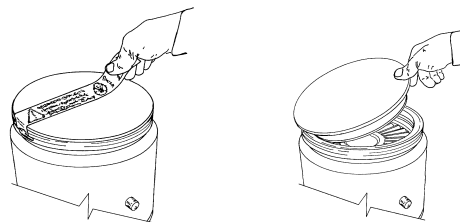

FLENS	TYPE KLEMME	ANT.	STRAMME-MOMENT
ISO 100	Dobbel klemme, gjenge M10	4	22 Nm
	Enkel klemme, gjenge M8	8	11 Nm
ISO 160	Dobbel klemme, gjenge M10	4	22 Nm
	Enkel klemme, gjenge M10	8	22 Nm
ISO 200	Dobbel klemme, gjenge M10	6	22 Nm
	Enkel klemme, gjenge M10	12	22 Nm

Turbopumpen med ConFlat inngangsfleus skal festes til vakuumkammeret ved hjelp av de spesielle låsedelene fra Varian. For detaljer henvises det til "Teknisk informasjon".

MERK

TV 551/701 Navigator må ikke festes gjennom fundamentet.

FORSIKTIG!

TV 551/701 Navigator hører til installasjonsklasse (eller overspenningsklasse) nummer 2 i følge EN 61010-1 standarden. Kople derfor anordningen til en hovedledning som tilfredsstillere kravene for denne klassen.

TV 551/701 Navigator er utstyrt med koplingsstykker for inn-/utgangene og seriekommunikasjonen som må koples til de ytre strømkretsene slik at ingen deler under spenning er tilgjengelige. Forsikre deg om at isoleringen av anordningen koplet til TV 551/701 Navigator har en egnet isolering, også under forhold med en enkel feil i følge EN 61010-1 standarden.

For installasjon av tilleggsutstyr vises det til "Teknisk informasjon".

BRUK

Alle instruksjoner for korrekt bruk finnes i dette avsnittet. Les nøye gjennom denne manualen før systemet tas i bruk. Mens oppvarmingen av kammeret pågår må temperaturen ved inngangsfleusen ikke overskride 120°C.

ADVARSEL!

Ikke start pumpen hvis inngangsfleusen ikke er koplet til vakuumkammeret, eller ikke er lukket med lukkefleusen.

Ikke berør turbopumpen eller noe av tilleggsutstyret under oppvarmingen. De høye temperaturene kan føre til brannskader.

FORSIKTIG!

Unngå støt, svingninger eller plutselige bevegelser av turbinpumpen når den er i funksjon. Lagrene kan skades.

Bruk støv- og partikkelfri luft eller inaktiv gass ved forsyning av pumpen. Trykket ved inngangen må ikke være mindre enn 2 bar (over atmosfærisk trykk).

Ved pumping av etsende gasser er disse pumpene utstyrt med en spesiell åpning. Til denne åpningen skal flyt av inaktive gasser (argon eller kvelstoff) koples for å beskytte lagrene (se "Teknisk informasjon").

ADVARSEL!

Når pumpen brukes for å pumpe giftige, brannfarlige eller radioaktive gasser skal de relevante forskriftene for de enkelte gasstypene følges.

Pumpen skal ikke brukes i eksplosjonsfarlige miljøer.

Starte og bruke TV 551/701 Navigator

TV 551/701 startes ved å sette strømkabelen i veggkontakten. Den innebygde styreenheten kjenner automatisk igjen blokkerings- og startsignaler, og starter pumpen.

Første igangsetting av pumpen skjer med MYK START, som etter denne første igangsettingscyklusen deaktiveres, slik at etterfølgende igangsettinger skjer uten MYK START. For å oppnå en MYK START igjen er det nødvendig å tilbakestille modusen via software (se avsnittet "RS 232 COMMUNICATION DESCRIPTION" i tillegget "Teknisk Informasjon").

Den grønne lysdioden LD1 på TV 551/701 basepanel angir systemets funksjon ved hjelp av blink:

- den lyser fast: pumpen roterer normalt
- den blinker langsomt (ca. hver 400 ms): systemet er i stilling for akselerasjon, bremsing, stopp eller "Waiting for interlock"
- den blinker hurtig (ca. hver 200 ms): feiltilstand.

Stoppe TV 551/701 Navigator

TV 551/701 Navigator stoppes ved å kople det fra strømforsyningen. Den innebygde styreenheten stanser pumpen umiddelbart.

Nødstop

Trekk ut nettkabelen fra styreenheten for å stoppe TV 551/701 Navigator i en nødsituasjon.

VEDLIKEHOLD

TV 551/701 Navigator er vedlikeholdsfritt. Alt arbeid på systemet må kun utføres av autorisert personell.

ADVARSEL!

Før noe arbeid gjøres på systemet må det frakoples tilførselen, pumpen må luftes ved å åpne den aktuelle ventilen og deretter vente til rotoren har stanset og pumpens overflatetemperatur er lavere enn 50°C.

Dersom systemet stanser, må du ta kontakt med Varians reparasjonsservice eller med Varians avanserte bytteservice som kan tilby overholte system til erstatning for det ødelagte systemet.

MERK

Før systemet returneres til produsenten for reparasjon, eller som innbytte for et overholt system, må det vedlagte skjemaet "Helse og sikkerhet" fylles inn og sendes til det lokale salgskontoret. En kopi av dette arket må vedlegges systemet som sendes tilbake.

Dersom et system skal kasseres, må dette skje i henhold til nasjonale bestemmelser.

YLEISIÄ TIETOJA

Tämä laite on tarkoitettu ammattimaiseen käyttöön. Ennen laitteen käyttöönottoa tulee käyttäjän lukea huolellisesti ohjekirja ja muut Varianin toimittamat lisätiedot. Varian ei ota vastuuta seurauksista, jotka johtuvat laitteen käyttöohjeiden täydellisestä tai osittaisesta laiminlyönnistä, ammattitaidottoman henkilön virheellisestä laitteen käytöstä, valtuuttamattomista toimenpiteistä tai kansallisen lainsäädännön vastaisesta käytöstä.

TV 551/701 Navigator on kokonaisjärjestelmä, joka muodostuu valvojalla varustetusta turbomolekyylipumpusta korkean ja ultrakorkean tyhjiön käyttöä varten. Järjestelmä kykenee pumppaamaan kaiken tyyppisiä kaasuja tai kaasukoostumuksia. Se ei sovellu nesteiden tai kiinteiden hiukkasten pumppaamiseen.

Pumppaus saadaan aikaan korkealla nopeudella (42000 kierrosta/min. max) pyörivän turbiinin avulla, jota käyttää korkeatehoinen kolmivaiheinen sähkömoottori. TV 551/701 Navigator -järjestelmässä ei ole lainkaan liikaavia aineita, joten se soveltuu myös "puhdasta" tyhjiötä vaativiin käyttötarpeisiin.

TV 551/701 Navigator -järjestelmään kuuluu lisäksi apuliittimiä, joiden avulla on mahdollista käyttää lisätuuletinta, ohjata tuuletusventtiiliä ja käyttää järjestelmää kauko-ohjauksella sarjakytetyin isäntätietokoneen avulla (RS 232/RS 485).

Seuraavissa kappaleissa on kaikki tarpeelliset tiedot laitteen käyttäjän turvallisuuden takaamiseksi laitteen käytön aikana. Yksityiskohtaiset tiedot löytyvät osasta "Tekniset tiedot".

Tämä käsikirja käyttää seuraavanlaisia merkintöjä:



VAARA!

Vaara-merkit saavat käyttäjän kiinnittämään huomion erityiseen käyttö- tai toimintatapaan, jonka vääränlainen suoritus voi johtaa vakaviin henkilövaurioihin.



HUOMIO!

Huomio-merkit varoittavat toiminnoista, joiden laiminlyönti voi johtaa laitteen vahingoittumiseen.

HUOM

Huomautukset sisältävät tärkeää tekstissä käsiteltyä tietoa.

VARASTOINTI

TV 551/701 Navigator -järjestelmän kuljetuksen ja varastoinnin aikana eivät seuraavat ympäristöä koskevat olosuhteet saa ylittyä:

- lämpötila: - 20°C - +70°C
- suhteellinen kosteus: 0 - 95% (ei tiivistävä)

Jos varastointiaika on hyvin pitkä, tulee pumppu käynnistää SOFT START-menetelmällä.

VALMISTELUT ASENNUSTA VARTEN

TV 551/701 Navigator toimitetaan erityisessä suoja-pakkauksessa; mikäli siinä on mahdollisesti kuljetuksen aikana tapahtuneita vaurioita, ottakaa yhteys paikalliseen myyntitoimistoon.

Pakkauksen purkamisen aikana tulee varoa erityisesti TV 551/701 Navigatorin putoamista tai siihen kohdistuvia iskuja tai tärinöitä. Pakkausta ei tule jättää ympäristöön. Pakkausmateriaali voidaan kierrättää kokonaisuudessaan ja se vastaa EY-direktiiviä 85/399 ympäristön suojelusta.



HUOMIO!

Jotta kaasun vuoto-ongelmilta vältyttäisiin, ei tyhjiölle altistuviin osiin tule koskea paljain käsin. Käyttäkää aina käsineitä tai muuta sopivaa suojausta.

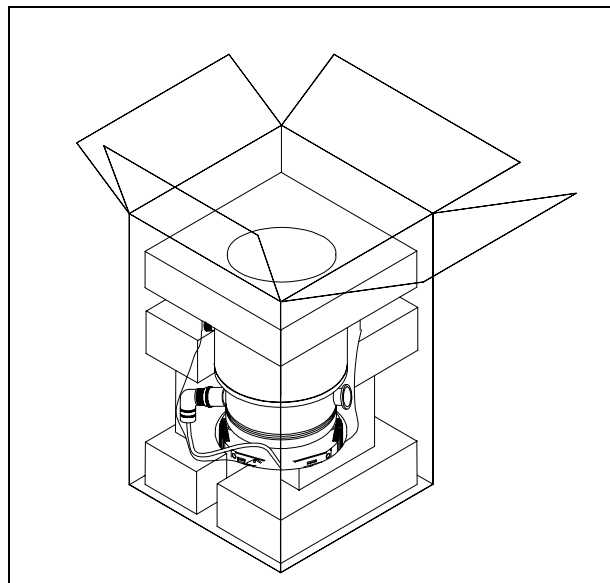

HUOM

TV 551/701 Navigator ei vahingoitu ollessaan kosketuksissa ilman kanssa (auki). On kuitenkin suositeltavaa pitää se suljettuna, kunnes se asennetaan järjestelmään. Siten vältetään laitteen mahdollinen pölysaastuminen.

ASENNUS

Pumppua ei tule asentaa ja/tai käyttää ympäristössä, missä se joutuu kosketuksiin säättekijöiden (sateen, jään tai lumen), pölyjen tai aggressiivisten kaasujen kanssa tai joissa on olemassa räjähdys- tai tulipalovaara.

Käytön aikana on noudatettava seuraavia ympäristöä koskevia ehtoja:

- maksimipaine: 2 baaria yli atmosfäärin paineen
- lämpötila: + 5°C - +35°C (ks. "Tekniset tiedot" -liitteen kaaviota).
- suhteellinen kosteus: 0 - 95 % (ei tiivistävä)

Mikäli läsnä on magneettikenttiä, tulee pumppu suojata tähän tarkoitukseen olevilla suojilla. Lisätietoja löytyy "Tekniset tiedot" -liitteestä.

TV 551/701 Navigator tulee kytkeä pääpumppuun (ks. "Tekniset tiedot" -liitteen kaaviota).

TV 551/701 Navigator voidaan asentaa mihin tahansa asentoon. Kiinnittäkää TV 551/701 Navigator vakaaseen asentoon liittämällä turbopumpun sisääntulolaippa kiinteään vastalaippaan, joka kestää 4000 Nm:n momentin akselinsa ympäri. Turbopumppu ISO-sisääntulolaipalla tulee kiinnittää tyhjiökammioon kaksois- tai yksinkertaisilla kiinnikkeillä. Seuraavassa taulukossa ovat kaikki laippakoot ja kiinnikemallit, kiinnikkeiden vaadittava määrä ja kiristysmomentti.



HUOMIO!

Irrottakaa teippi ja poistakaa suojakansi vasta, kun turbopumppu kytketään järjestelmään.

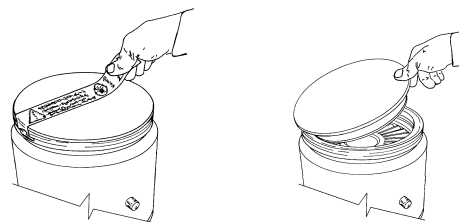

LAIPPA	KIINNIKE	MÄÄ-RÄ	KIRISTYS-MOMENTTI
ISO 100	Kaksoiskiinnike, kierteitys M10	4	22 Nm
	Yksinkertainen kiinnike, kierteitys M8	8	11 Nm
ISO 160	Kaksoiskiinnike, kierteitys M10	4	22 Nm
	Yksinkertainen kiinnike, kierteitys M10	8	22 Nm
ISO 200	Kaksoiskiinnike, kierteitys M10	6	22 Nm
	Yksinkertainen kiinnike, kierteitys M10	12	22 Nm

Turbopumppu ConFlat-sisääntulolaipalla tulee kiinnittää tyhjiökammioon sopivien Varianin mekaanisten varusteiden avulla. Lisätietoja löytyy "Tekniset tiedot" -liitteestä.

HUOM

TV 551/701 Navigatoria ei voida kiinnittää perustansa kautta.



HUOMIO!

TV 511/701 Navigator kuuluu toiseen EN 61010-1 säännösten mukaiseen asennusluokkaan (tai ylijänniteluokkaan). Kytke laite tämän vuoksi sähköverkkoon, joka täyttää tämän luokan vaatimukset.

TV 551/701 Navigator laitteissa on liittimet sisääntuloille/ulostuloille sekä sarjakytkenälle, jotka on kytkettävä ulkoisiin järjestelmiin siten, ettei mihinkään jännitteen alaisena olevaan osaan päästä käsiksi. Varmista, että TV 551/701 Navigator laitteeseen kytketyn laitteen eristys riittää myös yksittäisen toimintahäiriön yhteydessä EN 61010-1 säännösten edellyttämällä tavalla.

Ks. "Tekniset tiedot" -liitettä lisävarusteiden asentamista varten.

KÄYTTÖ

Tähän kappaleeseen on kirjattu tärkeimmät käyttötoimenpiteet. Suorittakaa ennen järjestelmän käyttöä kaikki sähkö- ja paineilmakytkennät. Tyhjiökammion mahdollisen lämmityksen aikana sisääntulolaipan lämpötila ei saa ylittää 120°C:ta.



VAARA!

Älkää käyttäkö pumppua, ellei sisääntulolaippaa ole kytketty tyhjiökammioon tai pumppua suljettu sulkulaipalla.

Älkää koskeko turbopumppuun tai sen lisäosiin lämmittämisen aikana. Korkea lämpötila saattaa aiheuttaa henkilöiden loukkaantumisia.



HUOMIO!

Vältä kolhuja, heiluntaa tai äkkiliikkeitä turbopumpun toiminnan aikana, sillä laakerit voivat vahingoittua.

Käytä pumppuun ilmansyöttöön ilmaa tai jalokaasua, joissa ei ole pölyä tai hiukkasia. Erityisen aukon läpi syötettävän paineen tulee olla alle 2 baaria (yli atmosfäärin paineen).

Pumput on varustettu aggressiivisten kaasujen pumppausta varten aukolla, jonka läpi pumppuun kuljetetaan jalokaasuja (typpi tai argon) laakereiden suojaamiseksi (katso "Tekniset tiedot" -liite).



VAARA!

Kun pumppua käytetään myrkyllisten, paloherkkien tai radioaktiivisten kaasujen pumppaamiseen, noudattakaa jokaiselle kaasulle sopivaa menettelytapaa.

Älkää käyttäkö pumppua räjähdysherkkien kaasujen lähellä.

TV 551/701 Navigatorin käynnistys ja käyttö

TV 551/701 Navigatorin käynnistykseen riittää, että se kytketään sähköverkkoon. Sisäänrakennettu valvoja tunnistaa automaattisesti lukitus- ja käynnistysignaalit ja käynnistää pumpun.

Pumpun ensimmäinen käynnistys tapahtuu "Soft Start" -menetelmällä, joka inaktivoituu automaattisesti käynnistysjakson jälkeen. Siten pumpun seuraavat käynnistykset tapahtuvat ilman "Soft Start" -toimintoa. Jotta käynnistys voitaisiin suorittaa uudelleen "Soft Start" -menetelmällä, tulee yllämainittu tapa aktivoida uudelleen ohjelmiston kautta (ks. kappale "RS 232 VIESTINNÄN KUVAAUS" "Tekniset tiedot" -liitteessä).

Vihreä LED LD1, joka sijaitsee TV 551/701:n perustan paneelissa, osoittaa vilkkumistiheydellään järjestelmän toimintaolosuhteet:

- palaa jatkuvasti: pumppu pyörii normaalisti;
- vilkkuu hitaasti (noin 400 ms:n jakso): systeemi on kiihdytys-, jarrutus-, pysäytys- tai "Waiting for interlock"-tilassa;
- vilkkuu nopeasti (noin 200 ms:n jakso): virhetila.

TV 551/701 Navigatorin pysäyttäminen

TV 551/701 Navigatorin pysäyttämiseen riittää, että se kytketään irti sähköverkosta. Sisäänrakennettu valvoja pysäyttää pumpun välittömästi.

Hätäpysäytys

TV 551/7012 Navigator on pysäytettävä hätätilassa irrottamalla sähkökaapeli ohjausyksiköstä.

HUOLTO

TV 551/701 Navigator ei vaadi lainkaan huoltoa. Mahdolliset toimenpiteet tulee jättää valtuutetun henkilön tehtäväksi.



VAARA!

Ennen minkään tyyppistä toimenpidettä järjestelmässä kytkekää se irti sähköverkosta, päästäkää pumppuun ilmaa avaamalla siihen tarkoitettu venttiili ja odottakaa roottorin täydellistä pysähtymistä. Antakaa tämän jälkeen pumpun pintalämmön laskea alle 50°C:en.

Laitteen vahingoittuessa on mahdollista käyttää Varianin korjauspalvelua tai "Varian advanced exchange service" -vaihtopalvelua, jonka kautta saatte uudistetun pumpun vahingoittuneen tilalle.

HUOM

Ennen järjestelmän lähettämistä valmistajalle korjausta tai vaihtopalvelua varten on ehdottomasti täytettävä ja toimitettava paikalliseen myyntitoimistoon "Turvallisuus ja Terveys" -kaavake, joka on liitteenä ohjekirjassa. Kyseisen kaavakkeen kopio tulee liittää järjestelmän pakkaukseen ennen sen lähettämistä.

Mikäli pumppu täytyy romuttaa, toimikaa sen hävittämisessä kansallisen lainsäädännön määräämällä tavalla.

ΓΕΝΙΚΕΣ ΠΛΗΡΟΦΟΡΙΕΣ

Αυτή η συσκευή προορίζεται για επαγγελματική χρήση. Ο χρήστης θα πρέπει να διαβάσει προσεκτικά τις οδηγίες του παρόντος εγχειρίδιου οδηγιών και οποιαδήποτε άλλη πρόσθετη πληροφορία που δίνει η Varian, πριν από τη χρησιμοποίηση της συσκευής. Η Varian δεν φέρει καμία ευθύνη όσον αφορά την ολική ή μερική αθέτηση των οδηγιών, την ακατάλληλη χρήση εκ μέρους ανεκπαίδευτου προσωπικού, μη εξουσιοδοτημένες επεμβάσεις ή χρήση που δεν συμφωνεί με τις ειδικές εθνικές διατάξεις. Το TV 551/701 Navigator είναι ένα ολοκληρωμένο σύστημα αποτελούμενο από μία στροβιλομοριακή αντλία για εφαρμογές υψηλού και υπερ - υψηλού κενού, ολοκληρωμένο από το σχετικό ελεγκτή (controller). Το σύστημα είναι ικανό να αντλήσει οποιοδήποτε είδος αερίου ή αεριούχο προιόν, αλλά δεν είναι κατάλληλο για την άντληση υγρών ή στερεών σωματιδίων.

Η ενέργεια άντλησης επιτυγχάνεται διαμέσου μίας τουρμπίνας που περιστρέφεται σε υψηλή ταχύτητα (42000 στρ.άλεπτ. max.) κινούμενη από έναν τριφασικό ηλεκτρικό κινητήρα υψηλών επιδόσεων. Το TV 551/701 Navigator στερείται παντελώς ρυπαντικών παραγόντων, οπότε είναι κατάλληλο για εφαρμογές οι οποίες απαιτούν ένα άκαθαρό κενό.

Το TV 551/701 Navigator έχει επίσης βοηθητικούς συνδετήρες διαμέσου των οποίων είναι δυνατή η τροφοδότηση ενός πρόσθετου ανεμιστήρα, ο έλεγχος της βαλβίδας αερισμού (vent), η καθοδήγηση από απόσταση διαμέσου ενός computer host συνδεδεμένου μέσω διατεταγμένης (serial) γραμμής (RS232/RS485). Στις επόμενες παραγράφους αναφέρονται όλες οι απαραίτητες πληροφορίες που εγγυούνται την ασφάλεια του χειριστή κατά τη διάρκεια της χρησιμοποίησης της συσκευής. Λεπτομερείς πληροφορίες δίνονται στο παράρτημα ΨΤεχνικές ΠληροφορίεςΨ. ("Technical Information")

Αυτό το εγχειρίδιο χρησιμοποιεί τους ακόλουθους συμβατικούς όρους

**ΚΙΝΔΥΝΟΣ!**

Οι ενδείξεις κινδύνου ελκύουν την προσοχή του χειριστή σε μία διαδικασία ή σε μία ειδική εργασία η οποία αν δεν εκτελεστεί σωστά, θα μπορούσε να προκαλέσει σοβαρές προσωπικές βλάβες.

**ΠΡΟΣΟΧΗ**

Οι ενδείξεις προσοχής εμφανίζονται πριν από τις διαδικασίες οι οποίες, αν δεν τηρηθούν, θα μπορούσαν να προκαλέσουν βλάβες στη συσκευή.

ΣΗΜΕΙΩΣΗ

Οι σημειώσεις περιέχουν σημαντικές πληροφορίες που έχουν αποσπαστεί από το κείμενο.

ΑΠΟΘΗΚΕΥΣΗ

Κατά τη διάρκεια της μεταφοράς και της αποθήκευσης του TV 551/701 Navigator πρέπει να τηρούνται οι ακόλουθες περιβαλλοντικές συνθήκες:

- θερμοκρασία: από -20°C ως +70°C
- σχετική υγρασία: 0 - 95% (αυξημένη)

Αν ο χρόνος αποθήκευσης είναι πολύ μεγάλος, ανάβετε την αντλία με τον τρόπο SOFT START.

ΠΡΟΕΤΟΙΜΑΣΙΑ ΓΙΑ ΤΗΝ ΕΓΚΑΤΑΣΤΑΣΗ

Το TV 551/701 Navigator προμηθεύεται σε μία ειδική προστατευτική συσκευασία: αν υπάρχουν ενδείξεις βλάβης που θα μπορούσαν να έχουν προκληθεί κατά τη διάρκεια της μεταφοράς, έρχεστε σε επαφή με το τοπικό τμήμα πωλήσεων.

Κατά τη διάρκεια του ανοίγματος της συσκευασίας, δώστε ιδιαίτερη προσοχή ώστε να μην αφηθεί και πέσει το TV 551/701 Navigator και να μην υποστεί χτυπήματα ή δονήσεις. Μην εγκαταλείπετε τη συσκευασία στο περιβάλλον. Το υλικό ανακυκλώνεται πλήρως και ανταποκρίνεται στην Οδηγία της Ε.Ο.Κ. 85/399 για τη διαφύλαξη του περιβάλλοντος.

**ΠΡΟΣΟΧΗ**

Για να αποφύγετε προβλήματα απαγωγής αερίου, μην αγγίζετε με γυμνά χέρια τα συστατικά που είναι προορισμένα να εκτεθούν στο κενό.

Χρησιμοποιείτε τα γάντια ή άλλη κατάλληλη προστασία.

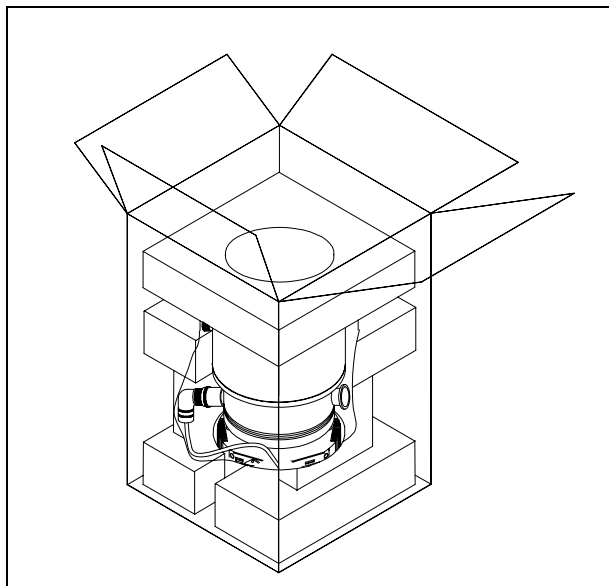
**ΣΗΜΕΙΩΣΗ**

Το TV 551/701 Navigator δεν βλέπεται απλά παραμένοντας εκτεθειμένο στο περιβάλλον. Εντούτοις συμβουλεύεται να διατηρείτε κλειστή την αντλία μέχρι τη στιγμή της εγκατάστασης στο σύστημα ώστε να αποφευχθεί μία ενδεχόμενη ρύπανση από σκόνη.

ΕΓΚΑΤΑΣΤΑΣΗ

Η αντλία δε θα πρέπει να εγκατασταθεί καιδή να χρησιμοποιηθεί σε χώρους εκτεθειμένους σε ατμοσφαιρικούς παράγοντες (βροχή, πάγο, χιόνι), σκόνης, χημικά αέρια, σε χώρους όπου υπάρχει κίνδυνος έκρηξης ή κίνδυνος πυρκαγιάς.

Κατά τη διάρκεια της λειτουργίας πρέπει να τηρούνται οι ακόλουθες συνθήκες περιβάλλοντος:

- μέγιστη πίεση: 2 bar πάνω από την ατμοσφαιρική πίεση
- θερμοκρασία: από + 5°C μέχρι + 35°C (βλέπε διάγραμμα στο παράρτημα ΨΤεχνικές ΠληροφορίεςΨ).
- σχετική υγρασία: 0 - 95% (αυξημένη).

Σε παρουσία ηλεκτρομαγνητικών πεδίων η αντλία πρέπει να προστατεύεται με κατάλληλα προκαλύμματα. Βλέπε το παράρτημα ΨΤεχνικές ΠληροφορίεςΨ για περισσότερες λεπτομέρειες.

Το TV 551/701 πρέπει να είναι συνδεδεμένο σε μία πρωτεύουσα αντλία (βλέπε σχήμα στις ΨΤεχνικές ΠληροφορίεςΨ).

Το TV 551/701 Navigator μπορεί να εγκατασταθεί σε οποιαδήποτε θέση. Στερεώστε το TV 551/701 Navigator σε σταθερή θέση ενώνοντας τη φλάντζα εισόδου της τουρμποαντλίας με μία σταθερή κόντροφλάντζα ικανή να αντέξει σε ένα ζεύγος 4000 Nm γύρω από τον άξονά της. Η τουρμποαντλία με φλάντζα εισόδου ISO πρέπει να στερεωθεί στον θάλαμο κενού μέσω διπλών ή μονών δαγκάνων. Η ακόλουθη ταμπέλλα περιγράφει, για κάθε μέγεθος φλάντζας και είδος δαγκάνης, τον απαραίτητο αριθμό δαγκάνων και με ποιο ζεύγος βιδώματος πρέπει να σφιχτούν.

**ΠΡΟΣΟΧΗ**

Ξεκολλήστε το αυτοκόλλητο και βγάλτε το προστατευτικό καπάκι μόνο τη στιγμή της σύνδεσης της τουρμποαντλίας στο σύστημα.

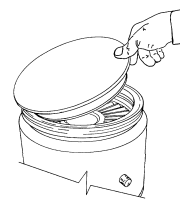

ΦΛΑΝΤΖΑ	ΕΙΔΟΣ ΔΑΓΚΑΝΗΣ	N.	ΖΕΥΓΟΣ ΒΙΩΜΑΤΟΣ
ISO 100	Διπλή δαγκάνη με ελίκωση M10	4	22 Nm
	Μονή δαγκάνη με ελίκωση M8	8	11 Nm
ISO 160	Διπλή δαγκάνη με ελίκωση M10	4	22 Nm
	Μονή δαγκάνη με ελίκωση M10	8	22 Nm
ISO 160	Διπλή δαγκάνη με ελίκωση M10	4	22 Nm
	Μονή δαγκάνη με ελίκωση M10	8	22 Nm

Η τουρμποαντλία με φλάντζα εισόδου ConFlat πρέπει να στερεωθεί στο θάλαμο κενού μέσω των κατάλληλων μηχανικών εξαρτημάτων Varian. Για περισσότερες λεπτομέρειες βλέπε το παράρτημα "Τεχνικές Πληροφορίες".

ΣΗΜΕΙΩΣΗ

Το TV 551/701 Navigator δεν μπορεί να στερεωθεί διαμέσου της βάσης του.



ΠΡΟΣΟΧΗ

Ο TV 551/701 Navigator ανήκει στη δεύτερη κατηγορία εγκαταστασιμότητας (ή υπερτασιμότητας) που προβλέπεται από τον κανονισμό EN 61010-1. Κατά συνεπεία συνδεάτε τη διατάξη σε μια γραμμή τροφοδοτησιμότητας η οποία ικανοποιεί αυτήν την κατηγορία.

Ο TV 551/701 Navigator εαχει βυασιματα για τη εισοαδοή/εξοαδοή και για τη σειριακη επικοινωνια που πρλαπει να συνδεθουαν στα εξοτερικα κυκλωματα εασι ωρασε να μην ειαναι προσιτα κανεανι μεαροή υποα ταραση. Βεβαιωθειατε οατι η μοανωση τηή συνδεμεανηή διαταξηή στον TV 551/701 Navigator εαχει μια κατααλληλη μοανωση ακοαμα και σε καταασιταση μονηαή βλααβηή οαπηή πρβλαπειτα αποα τον κανονισμοα EN 61010-1.

Για την εγκατάσταση των προαιρετικών αξεσουάρ, βλέπε "Τεχνικές Πληροφορίες".

ΧΡΗΣΗ

Σε αυτήν την παράγραφο αναφέρονται οι κυριότερες επιχειρησιακές διαδικασίες.

Πριν να χρησιμοποιήσετε το σύστημα πραγματοποιείτε όλες τις ηλεκτρικές και πνευματικές συνδέσεις. Κατά τη διάρκεια της ενδεχόμενης θέρμανσης του θαλάμου κενού, η θερμοκρασία στη φλάντζα εισόδου δεν πρέπει να ξεπερνάει τους 120°C.



ΚΙΝΔΥΝΟΣ!

Μην αφήνετε ποτέ να λειτουργεί η αντλία αν η φλάντζα εισόδου δεν είναι συνδεδεμένη στο θάλαμο κενού ή δεν είναι κλειστή με τη φλάντζα κλεισίματος.

Μην αγγίζετε την τουρμποαντλία και τα ενδεχόμενα εξαρτήματά της κατά τις εργασίες θέρμανσης. Η υψηλή θερμοκρασία μπορεί να προκαλέσει προσωπικές βλάβες.



ΠΡΟΣΟΧΗ

Αποφυαγετε συγκρουασειή, ολισθηασειή ηα αποατομηή μετακινηασειή τηή αντλιααή τουαρμπο οαταν βριαακεται σε λειτουργια. Θα μπορούααν να πααθουαν ζημιααή τα κουζιναατα. Για να διοχετευατε με αέρα την αντλία χρησιμοποιείτε αέρα ή αδρανές αέριο καθαρό από σκόνη ή άλλα στοιχεία. Η πίεση εισόδου διαμέσου της ειδικής πόρτας, πρέπει να είναι μικρότερη από 2 bar (πάνω από την ατμοσφαιρική πίεση)

Για την άντληση πολεμικών αερίων αυτές οι αντλίες είναι εφοδιασμένες με μια ειδική θυρίδα μέσω της οποίας είναι αναγκαία η διοχέτευση αδρανούς αερίου (Αζωτο ή Αργό) για να προστατευτούν τα έδρανα (βλέπε το παράρτημα "Τεχνικές Πληροφορίες")



ΚΙΝΔΥΝΟΣ!

Όταν η αντλία χρησιμοποιείται για την άντληση τοξικών, εύφλεκτων ή ραδιενεργών αερίων, ακολουθείτε τις κατάλληλες χαρακτηριστικές διαδικασίες του κάθε αερίου.

Μη χρησιμοποιείτε την αντλία παρουσία εκρηκτικών αερίων.

Έναυση και Χρήση του TV 551/701 Navigator

Για να ανάψετε το TV 551/701 αρκεί να προμηθεύσετε την τάση τροφοδοτήσης. Ο ενσωματωμένος controller αναγνωρίζει αυτομααατηή την παρουαααα των σημααατων interlock και εκκיאνησηή κι ανααβει την αντλιαα.

Η πρώτη εκκίνηση της αντλίας γίνεται με τον τρόπο "Soft Start", που στο τέλος του κύκλου έναυσης, απενεργοποιείται αυτομάτως, οπότε όλες οι επόμενες έναυσεις γίνονται χωρίς τον τρόπο "Soft Start". Για να έχετε ξανά μία εκκίνηση με ενεργό "Soft Start" χρειάζεται να αποκαταστήσετε τον αναφερθέντα τρόπο διαμέσου software (βλέπε την παράγραφο "RS 232 COMMUNICATION DESCRIPTION" στο παράρτημα "Τεχνικές Πληροφορίες").

Το πράσινο LED LD1 το οποίο βρίσκεται στο πλαίσιο της βάσης του TV 551/701 Navigator ενδεικνύει, με τη συχνότητα που αναβοσβήνει, τις επιχειρησιακές συνθήκες του συστήματος:

- σταθερά αναμένοη η αντλία είναι σε κανονική περιστροφή
- αναβοσβήνει αργά (περίοδος περίπου 400 ms): Το σύστημα είναι σε κατάσταση ανάβασης, ή επιβράδυνσης, ή stop, ή "Waiting for interlock".
- αναβοσβήνει γρήγορα (περίοδος περίπου 400 ms): εσφαλμένη συνθήκη.

Σταμάτημα του TV 551/701 Navigator

Για να σταματήσετε το TV 551/701 Navigator είναι αρκετό να αφαιρέσετε την τάση τροφοδοτήσης. Ο ενσωματωμένος ελεγκτής σταματά αμέσως την αντλία.

Σταμάτημα Έκτακτης Ανάγκης

Για να σταματηρασε σε συνθηκαεε εακτακτηε ανααγκηε το TV 551/701 Navigator πρλαπει να βγααλετε το καλωαδιο τρφοαοατηεε αποα τον controller.

ΣΥΝΤΗΡΗΣΗ

Το TV 551/701 Navigator δε χρειάζεται καμία συντήρηση. Οποιαδήποτε επέμβαση πρέπει να γίνεται από ειδικευμένο προσωπικό.



ΚΙΝΔΥΝΟΣ!

Πριν επιχειρήσετε οποιαδήποτε επέμβαση στο σύστημα, αποσυνδέστε το από την τροφοδοσία, κάντε εξαέρωση στην αντλία ανοίγοντας την ειδική βαλβίδα, περιμένετε μέχρι να σταματήσει τελείως ο ρότορ και αναμένετε η επιφανειακή θερμοκρασία της αντλίας να είναι κατώτερη από 50°C.

Σε περίπτωση βλάβης μπορείτε να απευθυνθείτε στο service της Varian ή στο "Varian advanced exchange service", που σας δίνει τη δυνατότητα να αντικαταστήσετε την χαλασμένη αντλία με μία άλλη αναζωογονημένη.

ΣΗΜΕΙΩΣΗ

Πριν επιστρέψετε στον κατασκευαστή την αντλία για επισκευή ή για advanced exchange service, εναα απαααίτητο να συμπληρωατε και να παρουαααατε στο τοπικό Γραφείο Παώηαεων, το έντυπο ώαγιουααία και Υγείααή συνημμένο στο παρών εαχειρίδιο οαηιων. Αντίγραφο του ίδιου έντυπου πρλαπει να υπάραει μέσα στη συακευααία τηε αντλιαε πρην από την αποατολή.

Όταν πλέον ένα σύστημα πρέπει να διαλυθεί, προχωρείτε στην εξουδετέρωσή του τηρώντας τις ειδικές εθνικές διατάξεις.

GENERAL INFORMATION

This equipment is destined for use by professionals. The user should read this instruction manual and any other additional information supplied by Varian before operating the equipment. Varian will not be held responsible for any events occurring due to non-compliance, even partial, with these instructions, improper use by untrained persons, non-authorized interference with the equipment or any action contrary to that provided for by specific national standards.

The TV 551/701 Navigator is an integrated system with a turbo-molecular pump for high and ultra-high vacuum applications with its relevant controller. The system can pump any type of gas or gas compound. It is not suitable for pumping liquids or solid particles. The pumping action is obtained through a high speed turbine (max. 42000 rpm) driven by a high-performance 3-phase electric motor. The TV 551/701 Navigator is free of contaminating agents and, therefore, is suitable for applications requiring a "clean" vacuum.

It is equipped with auxiliary connectors to supply an additional fan, to control the vent valve, to be controlled from a remote site by means of an host computer connected through a serial line (RS232 or RS485).

The following paragraphs contain all the information necessary to guarantee the safety of the operator when using the equipment. Detailed information is supplied in the appendix "Technical Information".

This manual uses the following standard protocol:



WARNING!

The warning messages are for attracting the attention of the operator to a particular procedure or practice which, if not followed correctly, could lead to serious injury.



CAUTION

The caution messages are displayed before procedures which, if not followed, could cause damage to the equipment.

NOTE

The notes contain important information taken from the text.

STORAGE

When transporting and storing the pumps, the following environmental requirements should not be exceeded:

- temperature: from -20° to +70 °C
- relative humidity: 0 - 95% (non-condensing)

If the storage time is long start the pump using the SOFT START mode.

PREPARATION FOR INSTALLATION

The TV 551/701 Navigator is supplied in a special protective packing. If this shows signs of damage which may have occurred during transport, contact your local sales office.

When unpacking the system, be sure not to drop it and avoid any kind of sudden impact or shock vibration to it.

Do not dispose of the packing materials in an unauthorized manner. The material is 100% recyclable and complies with EEC Directive 85/399.



CAUTION

In order to prevent outgassing problems, do not use bare hands to handle components which will be exposed to vacuum. Always use gloves or other appropriate protection.

NOTE

Normal exposure to the environment cannot damage the TV 551/701 Navigator. Nevertheless, it is advisable to keep it closed until it is installed in the system, thus preventing any form of pollution by dust.

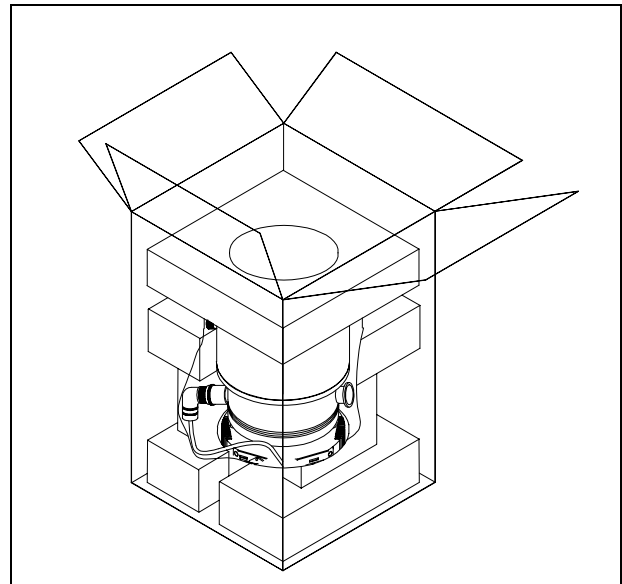

INSTALLATION

Do not install or use the pump in an environment exposed to atmospheric agents (rain, snow, ice), dust, aggressive gases, or in explosive environments or those with a high fire risk. During operation, the following environmental conditions must be respected:

- maximum pressure: 2 bar above atmospheric pressure
- temperature: from +5 °C to +35 °C (see the diagram pressure-temperature in the appendix "Technical Information")
- relative humidity: 0 - 95% (non-condensing)

In the presence of magnetic fields the pump must be protected using a ferromagnetic shield. See the appendix "Technical Information" for detailed information.

The TV 551/701 Navigator must be connected to a primary pump (see "Technical Information").

The TV 551/701 Navigator can be installed in any position. Fix the TV 551/701 Navigator in a stable position connecting the inlet flange of the turbopump to a fixed counter-flange capable of withstanding a torque of 4000 Nm around its axis.

The turbopump with ISO inlet flange must be fixed to the vacuum chamber by means of clamps or claws. The following table shows, for each flange and fixing device, the necessary number of clamps or claws and the relevant fixing torque.

FLANGE	FIXING DEVICE	N.	FIXING TORQUE
ISO 100	M10 clamps	4	22 Nm
	M8 claws	8	11 Nm
ISO 160	M10 clamps	4	22 Nm
	M10 claws	8	22 Nm
ISO 200	M10 clamps	6	22 Nm
	M10 claws	12	11 Nm



CAUTION!

Do not remove the adhesive and protective cap before connecting the turbopump to the system.

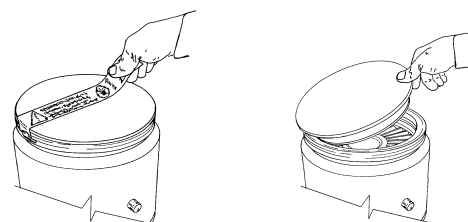

The turbopump with ConFlat inlet flange must be fixed to the vacuum chamber by means of the appropriate Varian hardware. See the appendix "Technical Information" for a detailed description.

NOTE

The TV 551/701 Navigator cannot be fixed by means of its base.

**CAUTION**

The TV 551/701 Navigator belongs to the second installation (or overvoltage) category as per directive EN 61010-1. Connect the device to a mains line that satisfy the above category. The TV 551/701 Navigator has Input/Output and serial communication connectors that must be connected to external circuits in such a way that no electrical part is accessible. Be sure that the insulation of the device connected to the TV 551/701 Navigator is adequate even in the case of single fault as per directive EN 61010-1.

For installation of optional accessories, see "Technical Information".

USE

This paragraph details the fundamental operating procedures. Make all electrical and pneumatic connections before the use of the system.

While heating the vacuum chamber, the temperature of the inlet flange must not exceed 120 °C.

**WARNING!**

Never use the turbopump when the inlet flange is not connected to the vacuum chamber or is not blanked.

Do not touch the turbopump or any of its accessories during the heating process. The high temperatures may cause burns.

**CAUTION**

Avoid impacts, oscillations or harsh movements of the pump when in operation. The bearings may become damaged.

Use air or inert gas free from dust or particles for venting the pump. The pressure at the vent port must be less than 2 bar (above atmospheric pressure).

For pumping aggressive gases, these pumps are fitted with a special port to allow a steady flow of inert gas (like N₂, Ar) for pump bearing protection (see the appendix "Technical Information").

**WARNING!**

When employing the pump for pumping toxic, flammable, or radioactive gases, please follow the required procedures for each gas disposal.

Do not use the pump in presence of explosive gases.

Switching on and Use of TV 551/701 Navigator

To switch on the TV 551/701 Navigator it is necessary to supply the mains. The integrated controller automatically recognizes the interlock and start signals presence and start up the pump.

The first pump start up is in "Soft Start" mode. When the start up cycle is finished, the "Soft Start" mode automatically is disabled, and the following start ups are without the "Soft Start" mode. To re-enable the "Soft Start" mode it must be activated by the suitable software command (see the paragraph "RS 232/485 COMMUNICATION DESCRIPTION" in the appendix "Technical Information").

The green LED located on the TV 551/701 Navigator base front panel indicates with its flashing frequency the system operating conditions:

- with no flashing: the pump is normally rotating;
- slowly flashing (period of about 400 ms): the system is in ramp, or in braking, or in Stop, or in "Waiting for interlock" status;
- fast flashing (period of about 200 ms): error condition.

TV 551/701 Navigator Switching off

To switch off the TV 551/701 Navigator it is necessary to remove the mains. The integrated controller immediately stops the pump.

Emergency Stop

To immediately stop the TV 551/701 Navigator in an emergency condition it is necessary to remove the supply cable from the mains plug.

MAINTENANCE

The TV 551/701 Navigator does not require any maintenance. Any work performed on the system must be carried out by authorized personnel.

**WARNING!**

Before carrying out any work on the system, disconnect it from the mains, vent the pump by opening the appropriate valve, wait until the rotor has stopped turning and wait until the surface temperature of the pump falls below 50 °C.

In the case of breakdown, contact your local Varian service center who can supply a reconditioned system to replace that broken down.

NOTE

Before returning the system to the constructor for repairs, or replacement with a reconditioned unit, the "Health and Safety" sheet attached to this instruction manual must be filled-in and sent to the local sales office. A copy of the sheet must be inserted in the system package before shipping.

If a system is to be scrapped, it must be disposed of in accordance with the specific national standards.

DESCRIPTION OF THE TV 551/701 NAVIGATOR

The TV 551/701 Navigator pumping system consists of a pump with a dedicated controller fixed to it. The system is available in four models for TV 551 and two models for TV 701. The models of each group differ in the high vacuum flange.

The TV 551 Navigator four models are:

- Model 969-8832 with ISO 160 high vacuum flange;
- Model 969-8833 with ConFlat 8" external diameter high vacuum flange;
- Model 969-98834 with ISO 100 high vacuum flange;
- Model 969-8835 with ConFlat 6" external diameter high vacuum flange.

The TV 701 Navigator two models are:

- Model 969-8836 with ISO 200 high vacuum flange;
- Model 969-8837 with ConFlat 10" external diameter high vacuum flange.

The following figures show the six models.

The pumps only are available with the following models:

1. TV 551 Navigator pumps:
 - Model 969-8922 with ISO 160 high vacuum flange
 - Model 969-8923 with ConFlat 8" external diameter high vacuum flange
 - Model 969-8924 with ISO 100 high vacuum flange
 - Model 969-8925 with ConFlat 6" external diameter high vacuum flange
2. TV 701 Navigator pumps:
 - Model 969-8926 with ISO 200 high vacuum flange
 - Model 969-8927 with ConFlat 10" external diameter high vacuum flange

The controller is also available as an option in two models:

- Model 969-8974 for TV 551 Navigator;
- Model 969-8975 for TV 701 Navigator.

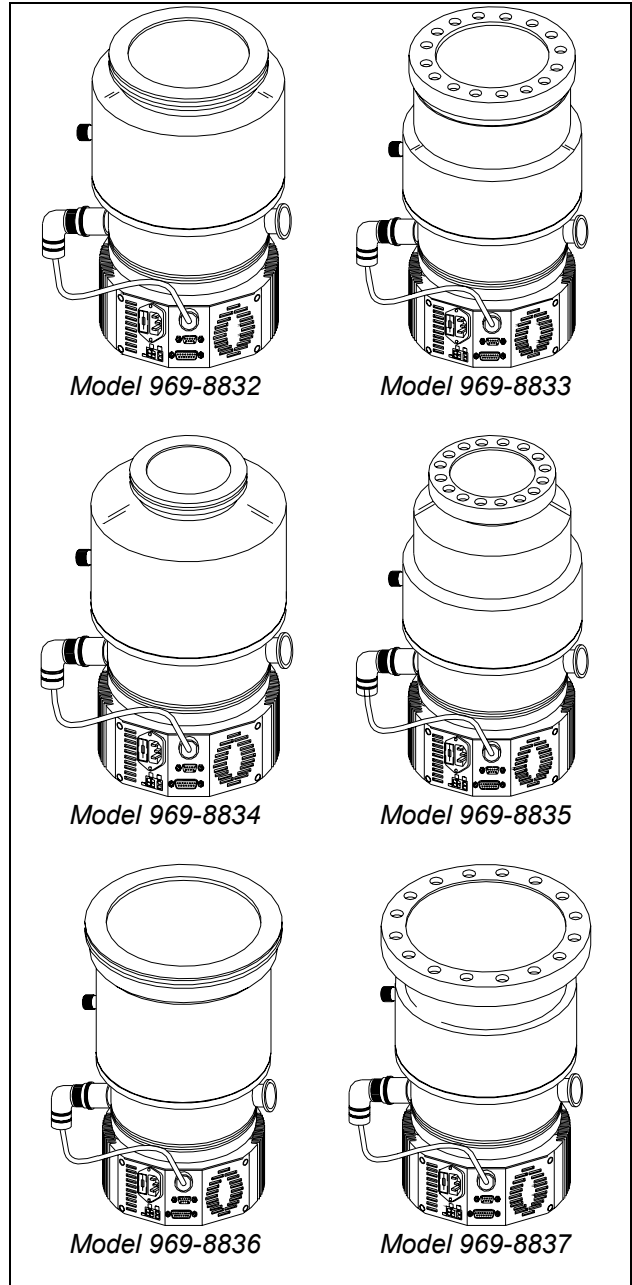

Pump Description

The pump consists of a high frequency motor driving a turbine fitted with 8 bladed stages and 4 Macrotrorr stages. The turbine rotates in an anti-clockwise direction when viewed from the high vacuum flange end.

The turbine is made of high-strength aluminium alloy, machined from a single block.

Proceeding from the high vacuum to the for vacuum region, the turbine stages sequence is:

- 1st stage with a blade angle of 40°,
- 2nd stage with a blade angle of 34°,
- 3rd stage with a blade angle of 28°,
- 4th and 5th stages with a blade angle of 24°,
- 6th stage with a blade angle of 20°,
- 7th and 8th stages with a blade angle of 16°.

The Macrotrorr stages are in the form of four discs.

The turbine rotor is supported by permanently lubricated high precision ceramic ball bearings installed on the forevacuum side of the pump.

The static blades of the stator are made of stainless steel. These are supported and accurately positioned by spacer rings.

The Macrotrorr stators are in the form of self-positioning machined discs with pumping channels and an opening restricted by the corresponding rotor discs. These are made of aluminium alloy.

During normal operation, the motor is fed with a voltage of 54 Vac three-phase at 715 Hz. To reduce losses during start-up to a minimum, the frequency increases according to a ramp with a higher initial voltage/frequency ratio.

The pump can be water cooled or air cooled: in the first case the customer can use the dedicated channels on the pump body, in the second case an external optional fan is available.

A thermistor sensor is mounted near the upper bearing to prevent the pump from overheating.

The pump is balanced after assembly with a residual vibration amplitude less than 0.01 μm .

The pump can operate in any position and can be supported on the high vacuum flange. The connection of the forevacuum on the side of the pump is a KF 25 NW flange.

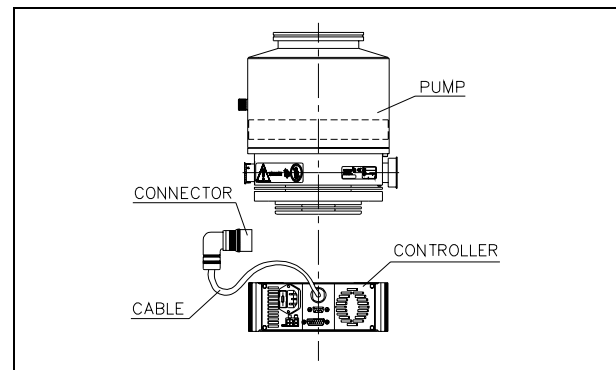

Controller Description

The dedicated controller is a solid-state frequency converter which is driven by a single chip micro-computer and is composed of two PCBs which include power supply and 3-phase output, analog and input/output section, microprocessor and digital section.

The power supply, together with the 3-phase output, converts the single phase AC mains supply into a 3-phase, low voltage, medium frequency output which is required to power the pump.

The controller can be operated by a remote host computer via the serial connection. A Windows-based software is available (optional).

TECHNICAL SPECIFICATION

CHARACTERISTIC	TV 551	TV 701	
Pumping speed (with inlet screen)	CFF 6"/ ISO100: 350 l/s He: 450 l/s H ₂ : 450 l/s	CFF 8"/ ISO160: 550 l/s 600 l/s 510 l/s	CFF 10"/ ISO200: 690 l/s 620 l/s 510 l/s
Compression ratio			
N ₂	1 x 10 ⁹	1 x 10 ⁹	
He	1 x 10 ⁷	1 x 10 ⁷	
H ₂	1 x 10 ⁶	1 x 10 ⁶	
Base pressure (According to standard DIN 28 428, the base pressure is that measured in a leak-free test dome, 48 hours after the completion of test dome bake-out, with a Turbopump fitted with a ConFlat flange and using the recommended pre-vacuum pump)	with minimum recommended mechanical pump: < 1 x 10 ⁻¹⁰ mbar (< 1 x 10 ⁻¹⁰ Torr) with minimum recommended diaphragm pump: 2 x 10 ⁻⁹ mbar (1.5 x 10 ⁻⁹ torr)		
Inlet flange	ISO 160, ISO 100, CF 6", CF 8"	ISO 200, CF 10"	
Foreline flange	KF 25 NW		
Rotational speed	42000 rpm		
Start-up time	< 5 minutes		
Recommended forepump			
Mechanical Diaphragm	Varian SD 300 Varian MD60	Varian 450 Varian MD60	
Operating position	Any		
Operating ambient temperature	+5 °C to +35 °C		
Cooling requirements	Natural air convection Water optional (use water with electrical conductivity ≤ 500 μS/cm)		
Cooling water	flow: 200 l/h (0.89 GPM) temperature: + 10° C to + 30° C pressure: 3 to 5 bar (45 to 75 Psi)		
Bakeout temperature	120° C at inlet flange max. (CF flange) 80° C at inlet flange max. (ISO flange)		

Vibration level (displacement)	< 0.01 μm at inlet flange	
Lubricant	permanent lubrication	
Noise level	<45 dB(A) at 1 meter	
Power supply:		
Input voltage:	100 to 240 Vac	
Input freq.:	50/60 Hz	
Max input power:	600 VA	
Stand-by power:	30 to 35 W	
Max operating power:	TV 551: 325 W with water cooling 220 W with air cooling	
	TV 701: 350 W with water cooling 250 W with air cooling	
Protection fuse	1 x 6.3 A	
Compliance with:	UNI EN 292-1 UNI EN 292-2 EN-CENELEC 55011 IEC 1000-4-2 (ex 801-2) IEC 1000-4-3 (ex 801-3) IEC 1000-4-4 (ex 801-4) EN 61010-1 (IEC 1010-1) EN 1012-2	
Power cable	With European or NEMA plug 3 meters long (optional)	
Serial communication (Navigator kit)	RS232 cable with a 9-pin D type male connector and a 9-pin D type female connector, and Navigator software (optional)	
Storage temperature	-20° C to +70° C	
Weight kg (lbs)		
ISO flange	19.4 (43)	19.4 (43)
CF flange	23.4 (51.6)	25.5 (54.2)
Controller	5.4 (12)	

NOTE

When the TV 551/701 Navigator has been stored at a temperature less than 5°C, wait until the system has reached the above mentioned temperature.

TV 551/701 NAVIGATOR OUTLINE

The following figures show the TV 551/701 Navigator outlines (dimensions are in inches [mm]).

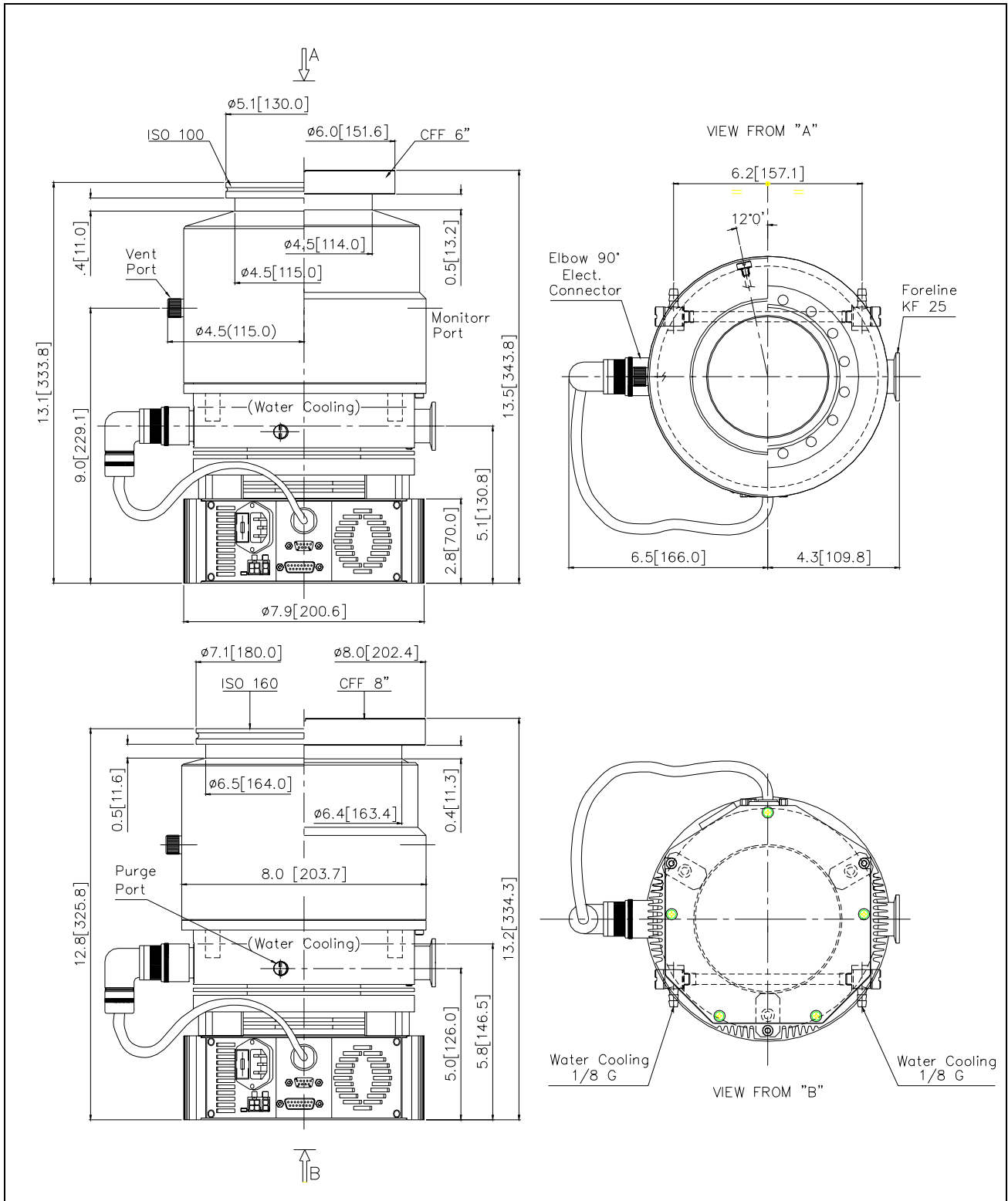

TV 551 Navigator outline

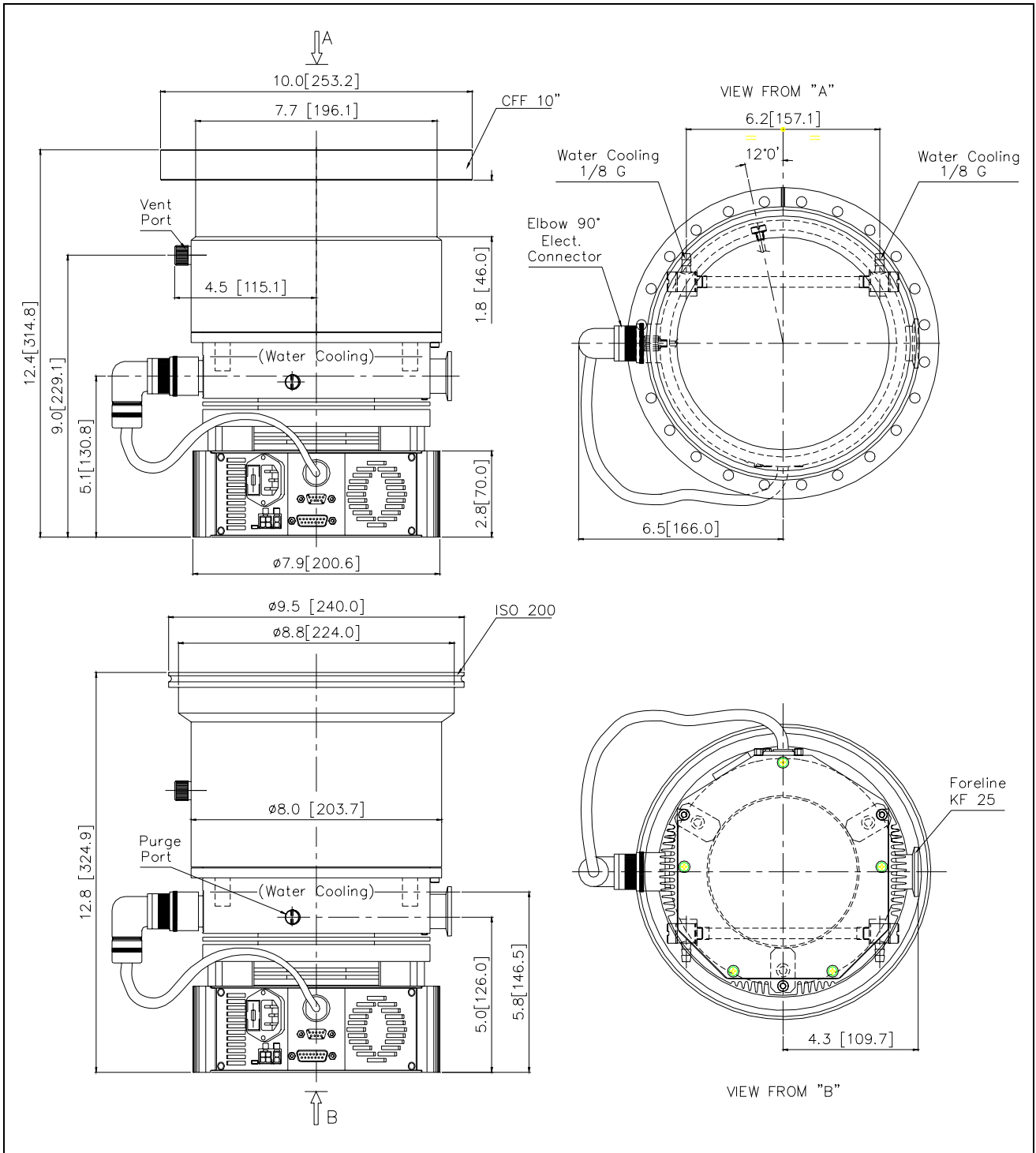

TV 701 Navigator outline

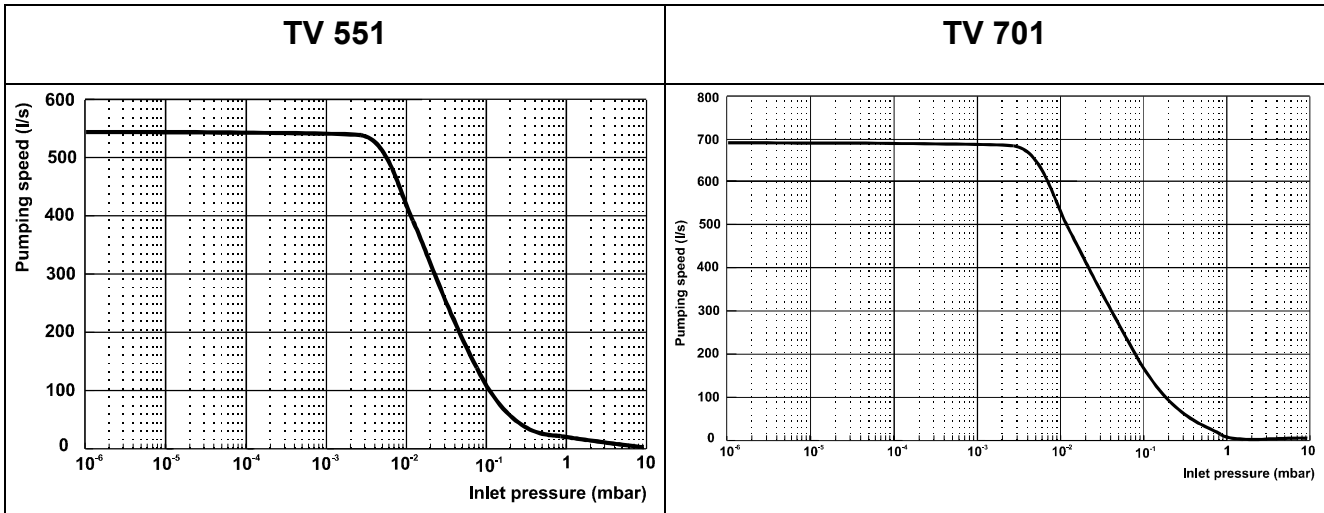

Graph of nitrogen pumping speed vs inlet pressure (with inlet screen)

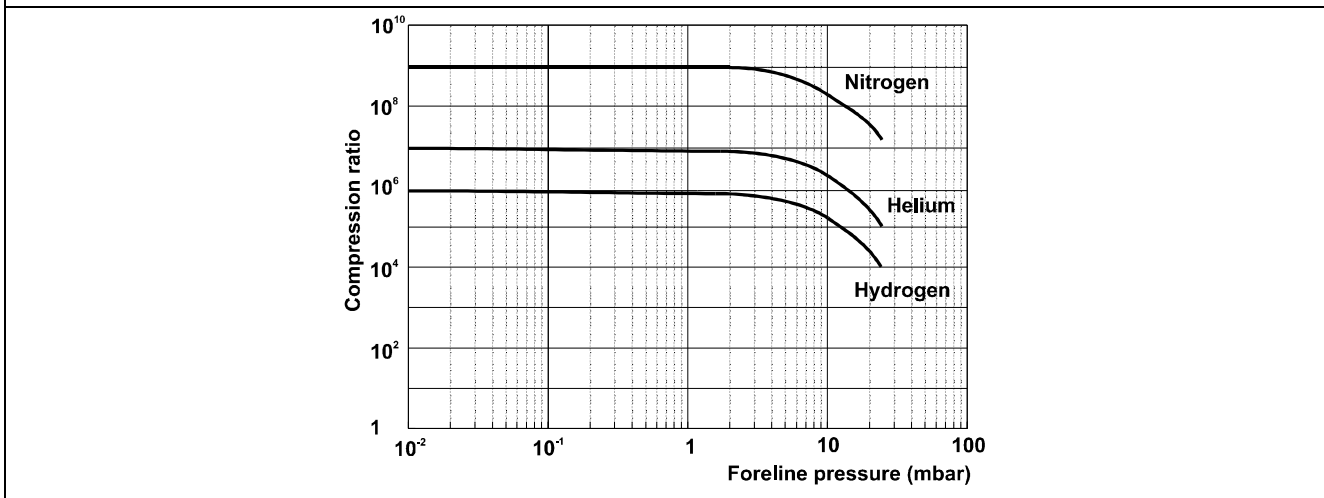

Graph of compression ratio vs foreline pressure

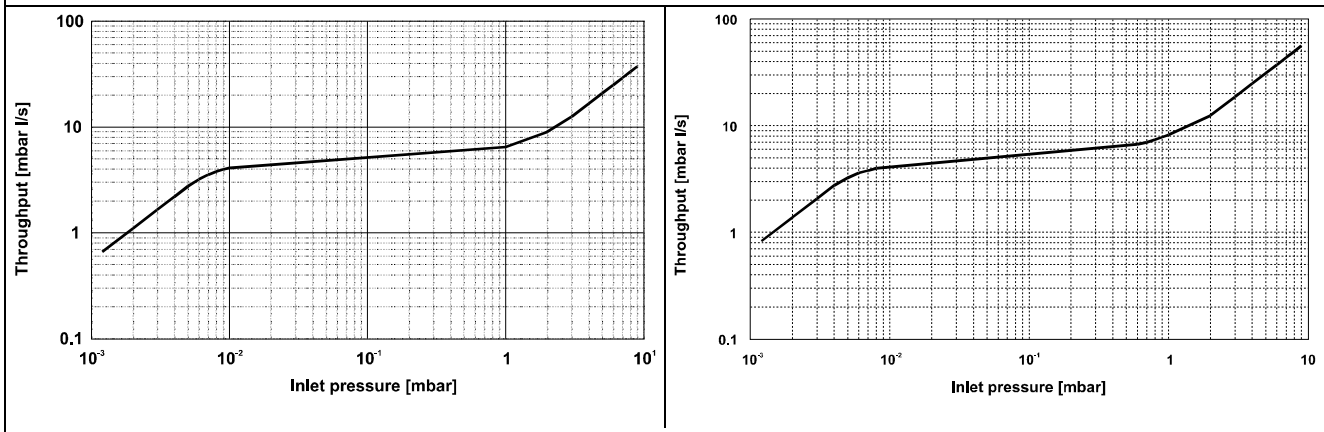

Graph of nitrogen throughput vs inlet pressure using the recommended mechanical forevacuum pump

INTERCONNECTIONS

The following figure shows the TV 551/701 interconnections.

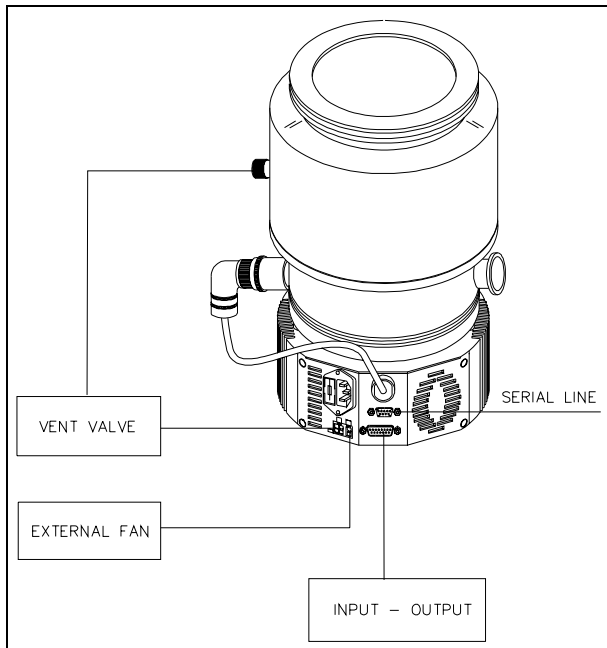

P3 - Vent

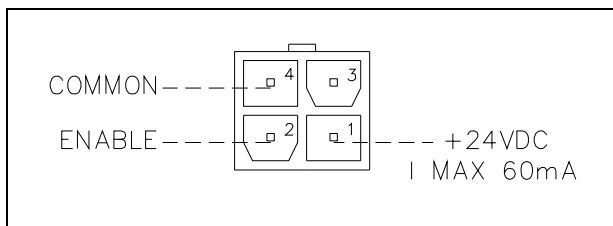

This is a dedicated 24 Vdc connector to control the optional vent valve.

P4 – External fan

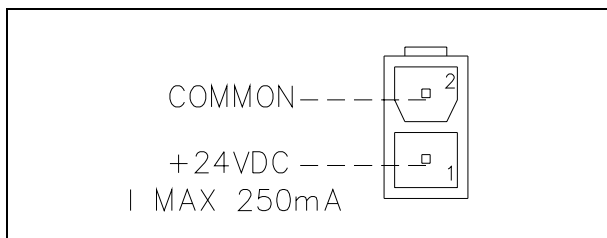

This is a dedicated 24 Vdc connector to supply the optional external fan.

J1 - IN-OUT

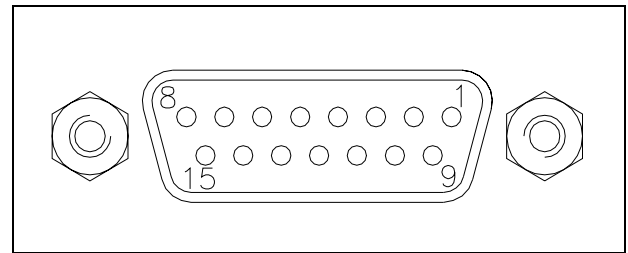

This connector carries all the input and output signals to remote control the TV 551/701 Navigator.

It is a 15-pins D type connector; the available signals are detailed in the table, the following paragraphs describe the signal characteristics and use.

PIN N.	SIGNAL NAME	INPUT/OUTPUT
1	START/STOP (+)	I
2	START/STOP (-)	I
3	INTERLOCK (+)	I
4	INTERLOCK (-)	I
5	SPEED SETTING (+)	I
6	SPEED SETTING (-)	I
7	SOFT START (+)	I
8	SOFT START (-)	I
9	+24 Vdc	O
10	SPARE	
11	PROGRAMMABLE SET POINT	O
12	SPARE	
13	FAULT OUTPUT	O
14	PROGRAMMABLE ANALOG SIGNAL (+)	O
15	<ul style="list-style-type: none"> GROUND PROGRAMMABLE ANALOG SIGNAL (-) 	O

Signal description

START/STOP: input signal to start or stop the pump. With the supplied cover connector the START/STOP (+) signal is connected to the +24 Vdc pin and the START/STOP (-) signal to the GROUND pin: in this condition the pump automatically starts as soon as the controller recognises the input supply ("Plug & Pump").

INTERLOCK: input signal to control the pump rotation. With the supplied cover connector the INTERLOCK (+) signal is connected to the +24 Vdc pin and the INTERLOCK (-)signal to the GROUND pin.

SPEED SETTING: PWM input signal to set the pump speed. The PWM signal characteristics must be the following:

- frequency: 100 Hz +/-20%
- amplitude: 24 V max
- duty cycle range: from 25% to 75%
- corresponding to a pump speed from 272 Hz to 714 Hz (see the following diagram).

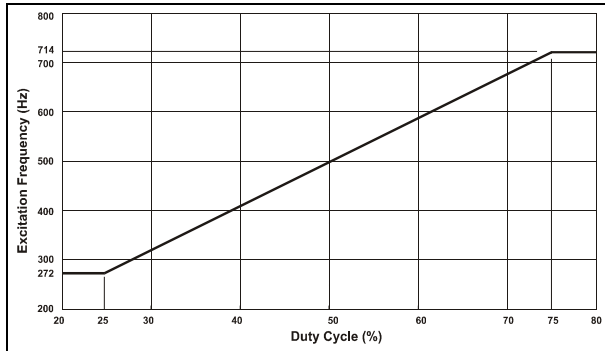

SOFT START: this input is used to provide a "soft start" to the pump; in this condition the ramp-up time could be up to 150 min.

PROGRAMMABLE ANALOG SIGNAL: this output signal is a voltage (from 0 to 10 Vdc) proportional to a reference quantity (frequency or power) set by the user. The default setting is the frequency (see the following example diagrams).

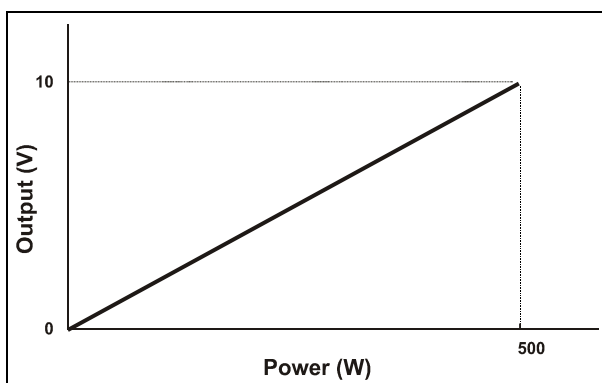
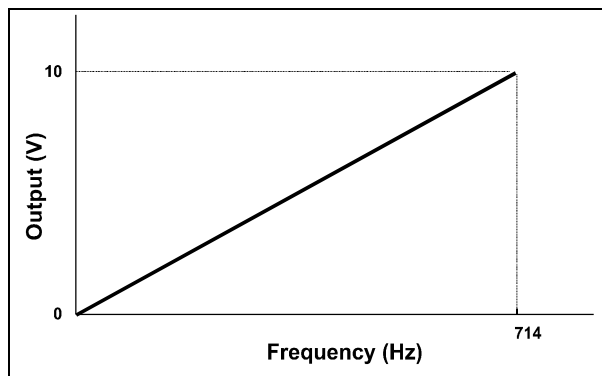

FAULT: this open collector output signal is ON when a system fault condition is detected.

PROGRAMMABLE SET POINT: this open collector output signal is enabled when the reference quantity chosen (frequency, current or time) is higher than the set threshold. The signal can be "high level active" (that is the output is normally at 0 Vdc and becomes 24 Vdc when activated), or "low level active" (that is the output is normally at 24 Vdc and becomes 0 Vdc when activated). Moreover, if the reference quantity is the frequency or the current drawn, it is possible to set the hysteresis (in % of the threshold value) to avoid bouncing.

For example:

- reference quantity: frequency
- threshold: 500 Hz
- hysteresis: 1%
- activation type: "high level"

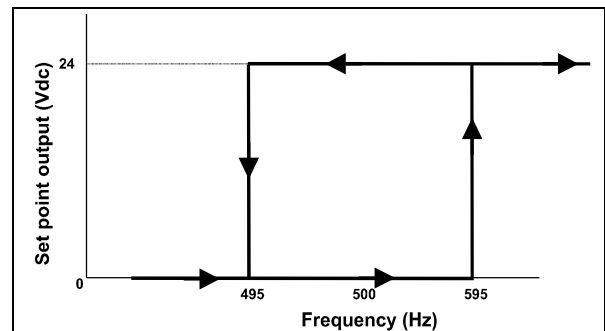

The set point output stays at 0 Vdc until the frequency becomes higher than 505 Hz (that is 500 Hz + 1% of 500 Hz), then the output goes at 24 Vdc and stays at 24 Vdc until the frequency becomes lower than 495 Hz (that is 500 Hz - 1% of 500 Hz).

It is possible to delay the set point checking for a programmable delay time.

The PROGRAMMABLE SET POINT signal has the following default settings:

- reference quantity: frequency
- threshold: 643 Hz
- hysteresis: 2%
- activation type: high level
- delay time: 0 second

NOTE

The Navigator Software (optional) allows the operator to set all the programmable feature.

When no external input-output device is available this connector must be closed with the supplied mating connector that short-circuits the START and INTERLOCK inputs with the GROUND input (see the following figure).

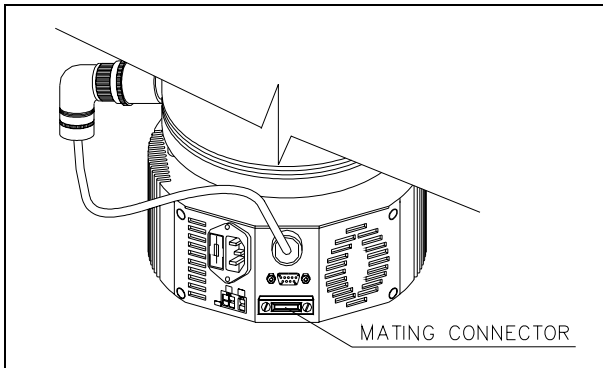

How to connect the output open collector of the controller

Here below there are the typical connections of the output open collector of TV551/701 Navigator to an external system. Two cases are considered:

1. the customer supplies the 24 Vdc
2. the customer does not supply the 24 Vdc.

Please note that on the connector a 24 Vdc, 60 mA voltage, a GROUND signal and the open collector pin are available.

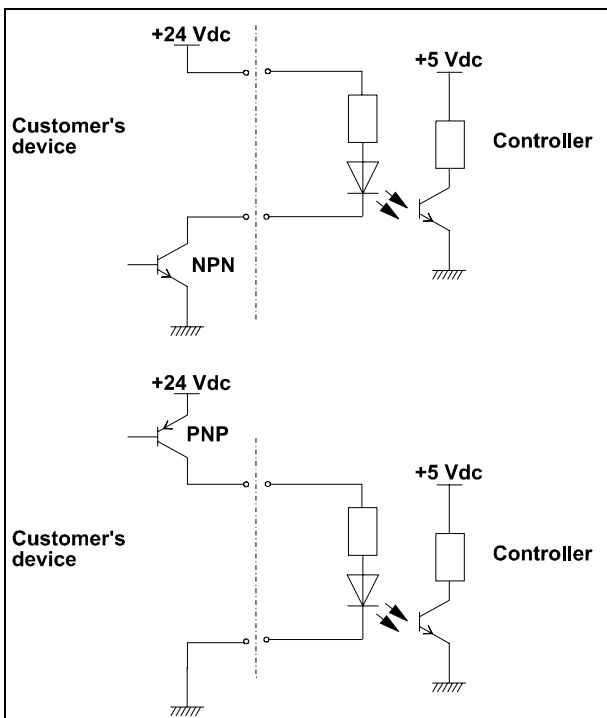

Case 1

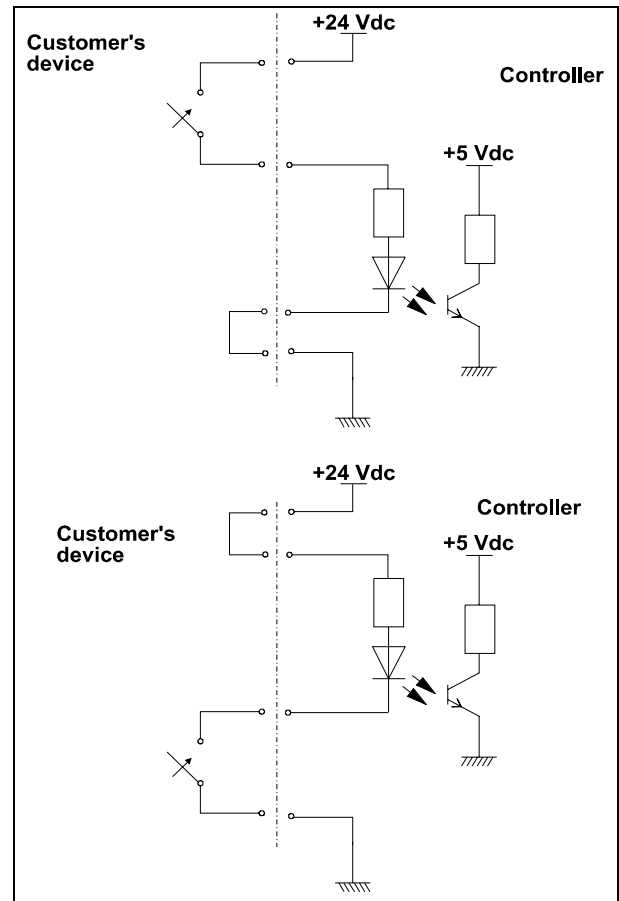

Case 2 with relay utilisation

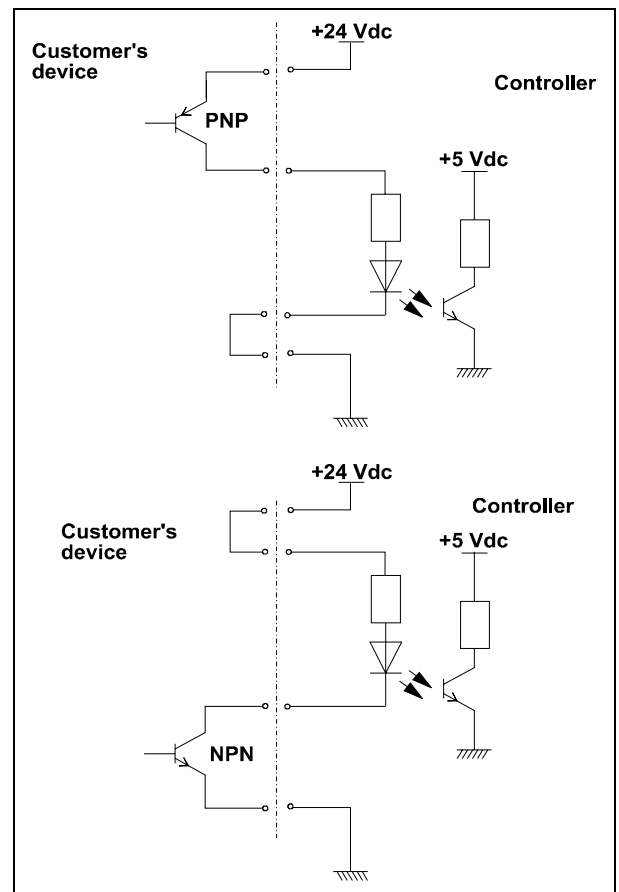

Case 2 with transistor utilisation

P2 - Serial

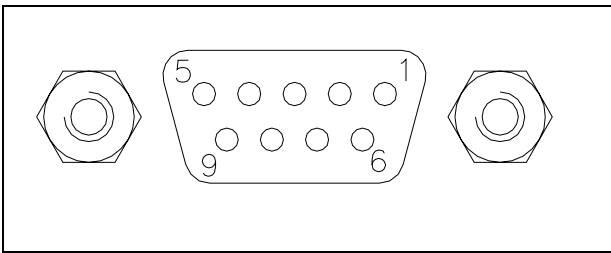

This is a 9 pin D-type serial input/output connector to control via an RS 232 or RS 485 connection the TV 551/701.

PIN N.	SIGNAL NAME
1	SPARE
2	TX (RS232)
3	RX (RS232)
4	SPARE
5	GND
6	A + (RS485)
7	SPARE
8	B - (RS485)
9	RESERVED

Note that the vent valve can also be controlled by means of the serial connection.

A serial communication kit with a serial cable and the Navigation software is available (optional).

RS 232/RS 485 COMMUNICATION DESCRIPTION

Both the RS 232 and the RS 485 interfaces are available on the connector P2.

The communication protocol is the same (see the structure below), but only the RS 485 manages the address field. Therefore to enable the RS 485 is necessary to select the type of communication as well as the device address by means of the Navigator software.

Communication Format

- 8 data bit
- no parity
- 1 stop bit
- baud rate: 600/1200/2400/4800/9600 programmable

Communication Protocol

The communication protocol is a MASTER/SLAVE type where:

- Host = MASTER
- Controller = SLAVE

The communication is performed in the following way:

1. the host (MASTER) send a MESSAGE + CRC to the controller (SLAVE);
2. the controller answer with an ANSWER + CRC to the host.

The MESSAGE is a string with the following format:

<STX>+<ADDR>+<WIN>+<COM>+<DATA>+<ETX>+<CRC>

where:

NOTE

When a data is indicated between two quotes ('...') it means that the indicated data is the corresponding ASCII character.

- <STX> (Start of transmission) = 0x02
- <ADDR> (Unit address) = 0x80 (for RS 232)
<ADDR> (Unit address) = 0x80 + device number (0 to 31) (for RS 485)
- <WIN> (Window) = a string of 3 numeric character indicating the window number (from '000' to '999'); for the meaning of each window see the relevant paragraph.
- <COM> (Command) = 0x30 to read the window, 0x31 to write into the window
- <DATA> = an alphanumeric ASCII string with the data to be written into the window. In case of a reading command this field is not present. The field length is variable according to the data type as per the following table:

DATA TYPE	FIELD LENGTH	VALID CHARACTERS
Logic (L)	1	'0' = OFF '1' = ON
Numeric (N)	6	'-', '.', '0' ... '9' right justified with '0'
Alphanumeric (A)	10	from blank to '_' (ASCII)

- <ETX> (End of transmission) = 0x03
- <CRC> = XOR of all characters subsequent to <STX> and including the <ETX> terminator. The value is hexadecimal coded and indicated by two ASCII character.

The addressed SLAVE will respond with an ANSWER whose structure depends from the MESSAGE type.

When the MESSAGE is a reading command, the SLAVE will respond transmitting a string with the same structure of the MESSAGE.

NOTE

Using the RS 485 interface, the message structure remains identical to the one used for the RS 232 interface, the only difference being that the value assigned to the ADDRESS <ADDR>

Examples:

Command: START
Source: PC
Destination: Controller

02	80	30	30	30	31	31	03	42	33
STX	ADDR	WINDOW			WR	ON	ETX	CRC	

Source: Controller
Destination: PC

02	80	06	03	38	35
STX	ADDR	ACK	ETX	CRC	

Command: STOP
Source: PC
Destination: Controller

02	80	30	30	30	31	30	03	42	32
STX	ADDR	WINDOW			WR	OFF	ETX	CRC	

Source: Controller
Destination: PC

02	80	06	03	38	35
STX	ADDR	ACK	ETX	CRC	

Command: SOFT-START (ON)
Source: PC
Destination: Controller

02	80	31	30	30	31	31	03	42	32
STX	ADDR	WINDOW			WR	ON	ETX	CRC	

Source: Controller
Destination: PC

02	80	06	03	38	35
----	----	----	----	----	----

STX	ADDR	ACK	ETX	CRC	
-----	------	-----	-----	-----	--

Command: SOFT-START (OFF)
Source: PC
Destination: Controller

02	80	31	30	30	31	30	03	42	33
STX	ADDR	WINDOW			WR	OFF	ETX	CRC	

Source: Controller
Destination: PC

02	80	06	03	38	35
STX	ADDR	ACK	ETX	CRC	

Window Meanings

N.	Read/Write	Data Type	Description	Admitted Values
000	R/W	L	Start/Stop (in remote mode the window is a read only)	Start = 1 Stop = 0
008	R/W	L	Remote (default) or Serial configuration	Remote = 1 Serial = 0 (default = 1)
100	R/W	L	Soft Start (write only in Stop condition)	YES = 1 NO = 0 (default = 1 the first time and 0 the following)
101	R/W	N	Set Point type	0 = Frequency 1 = Current 2 = Time (default = 0)
102	R/W	N	Set Point threshold (expressed in Hz, mA or s)	(default = 643)
103	R/W	N	Set Point delay: time between the pump start and the set point check (seconds)	0 to 99999 (default = 0)
104	R/W	L	Set Point signal activation type: the signal can be "high level active" or "low level active"	0 = high level active 1 = low level active (default = 0)
105	R/W	N	Set point hysteresis (in % of threshold)	0 to 100 (default = 2)
106	R/W	L	Intercooling	0 = NO 1 = YES

N.	Read/Write	Data Type	Description	Admitted Values
107	R/W	L	Active Stop (write only in stop)	0 = NO 1 = YES
108	R/W	N	Baud rate	600 = 0 1200 = 1 2400 = 2 4800 = 3 9600 = 4 (default = 4)
109	W	L	Pump life/cycle time/cycle number reset	To reset write '1'
110	R/W	L	Interlock type (default = 1)	Impulse = 0 Continuous = 1
111	R/W	L	Analog output type: output voltage signal proportional to frequency or power	0 = frequency 1 = power (default = 0)
120	R/W	N	Rotational frequency setting (Hz)	272 to 714 (default = 714)
121	R/W	N	Maximum rotational frequency in Hz (active only in Stop condition)	272 to 714 (default = 714)
122	R/W	L	Set vent valve on/off (on = closed)	On = 1 Off = 0 (default = 1)
123 124	Reserved to Varian service			
125	R/W	L	Set the vent valve operation	Automatic = 0 (see note 1.) On command = 1 (see note 2.)
126	R/W	N	Vent valve opening delay (expressed in 0.2 sec)	0 to 65535 (corresponding to 0 to 13107 sec)
130	Reserved to Varian service			
200	R	N	Pump current in mA dc	
201	R	N	Pump voltage in Vdc	
202	R	N	Pump power in W (pump current x pump voltage duty cycle)	
203	R	N	Driving frequency in Hz	

N.	Read/Write	Data Type	Description	Admitted Values
204	R	N	Pump temperature in °C	0 to 70
205	R	N	Pump status	Stop = 0 Waiting intlk = 1 Starting = 2 Auto-tuning = 3 Braking = 4 Normal = 5 Fail = 6
206	R	N	Error code	Bit description: see the following figure
210	R (see note 3.)	N	Actual rotation speed in Hz	150 to 714
300	R	N	Cycle time in minutes (zeroed by the reset command)	0 to 4x10 ⁹
301	R	N	Cycle number (zeroed by the reset command)	0 to 4x10 ⁹
302	R	N	Pump life in hours (zeroed by the reset command)	0 to 4x10 ⁹
320 to 399	Reserved to Varian service			
400	R	A	CRC EPROM (QE)	QE5XXXX (where "XXXX" are variable)
402	R	A	CRC Param. (PA)	PA5XXXX (where "XXXX" are variable)
500	Reserved to Varian service			
503	R/W	N	RS 485 address	0 to 31 (default = 0)
504	R/W	L	Serial type select	0 = RS 232 1 = RS 485 (default = 0)

NOTES

1. Automatic means that when the controller stops, the vent valve is opened with a delay defined by window n. 126; when the controller starts, the vent valve is immediately closed.
2. On command means that the vent valve is opened or closed by means of window n. 122.
3. These commands remove the pump motor supply for a short time. If they are used continuously, they can cause the pump stopping.

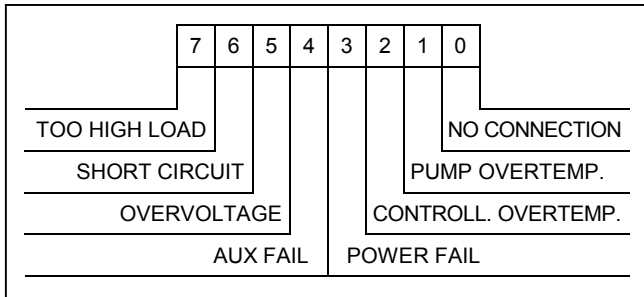

Window N. 206 Bit Description

INLET SCREEN INSTALLATION

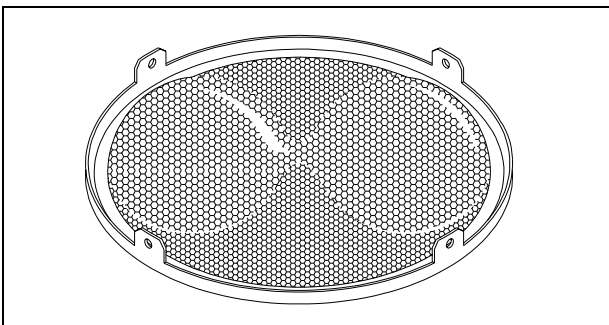
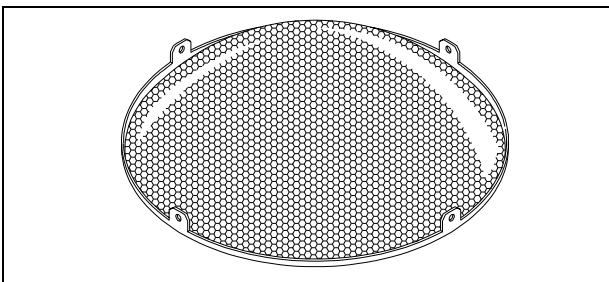
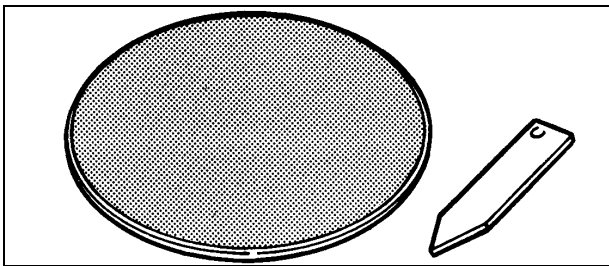

The inlet screens mod. 969-9302, 969-9304 and 969-9316 prevents the blades of the pump from being damaged by debris greater than 0.7 mm diameter.

The inlet screen, however, does reduce the pumping speed by about 10%.

The inlet screen is fitted in the upper part of the pump, as shown in the figure.

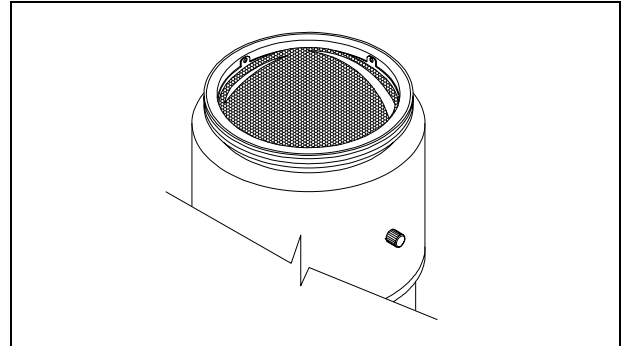

The screen can be mounted on each pump.

The screen can be removed as shown in the following figure.

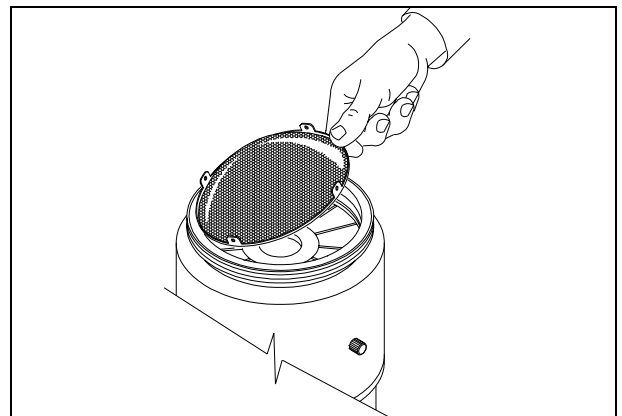

The following figure shows the overall flange dimensions with the protection screen fitted on pump with ISO flange and pump with CFF flange.

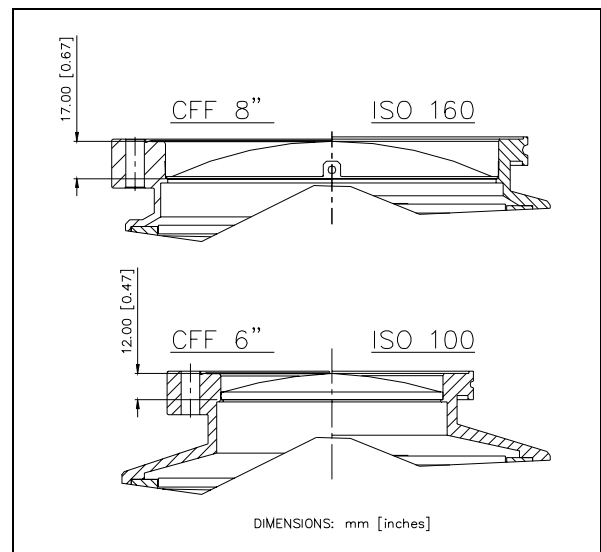

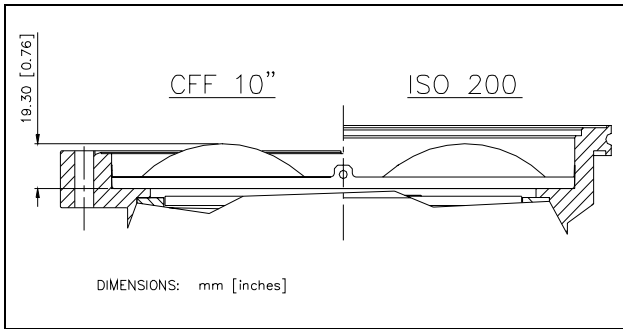

HEATER BAND INSTALLATION

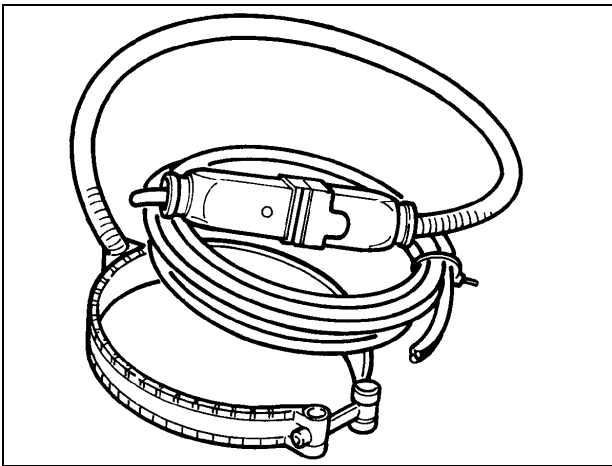

The heater band model 969-9808 and 969-9807 can be used to heat the pump casing when a bakeout is needed.

The heater band is applied to the upper part of the pump casing, as shown in the figure, and heats it to a temperature of about 80° C.

The heater band must be mounted such that there is perfect thermal contact with the pump wall to obtain fast and efficient heating.

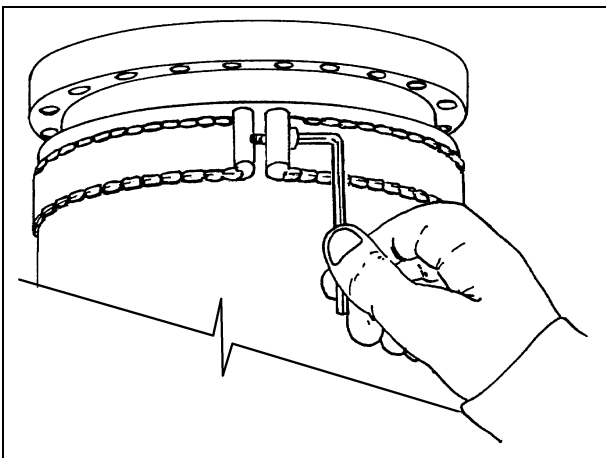

Switch on the heater while the turbopump is in operation. In the event of turbopump overheat, the pump will be automatically cut out by the thermistor sensor.

NOTE

The turbopump must be "baked" only when operating with an inlet pressure less than 10^{-4} mbar and with water cooling.

CAUTION

If the chamber of the system is "baked" at a high temperature, a shield should be installed to prevent thermal radiation heating the high vacuum flange on the pump. The maximum temperature allowed for the inlet flange is 120° C.

AIR COOLING KIT INSTALLATION

TV 551/701 with Navigator Controller

An air cooling kit (mod. 969-9339) is available to improve the TV 551/701 cooling during heavy operational conditions (optional).

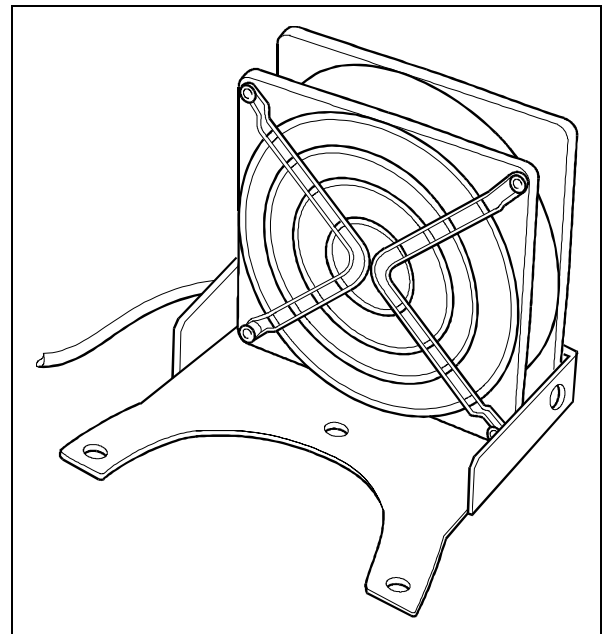

Fan specifications:

- air flow: 200m³/h
- input voltage: 24 Vdc
- dimensions: 127 x 127 x 38 mm (5 x 5 x 1.5 in.)
- power: 4.7 W

The fan bracket is shaped so that it can be mounted close to the pump.

To fix the fan to the TV 551/701 case execute the following procedure (see the following figure):

1. Fix the fan to the suitable bracket by means of the furnished screws;
2. Fix the bracket to the pump body between the pump and the controller;
3. Connect the fan supply to the P4 connector of the controller.

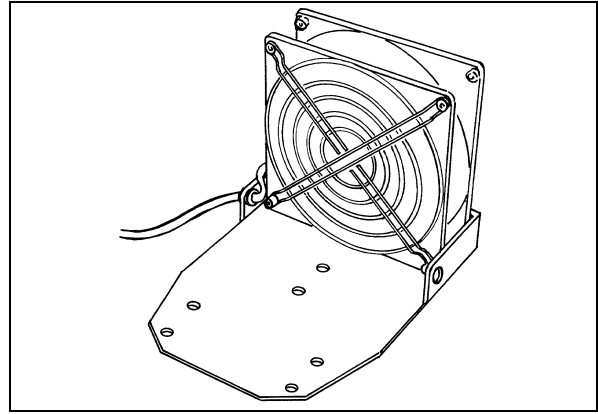

Fan specification:

- air flow: 25 l/s (51 CFM)
 - input voltage: 120 Vac 50-60 Hz
 - maximum power: 17 W
 - dimensions: 119 x 119 mm (4.69 x 4.79 inches)
- To fix the fan to the pump, position it ensuring that the holes in the plate line up with those in the pump base.

Insert the respective washers and screws and tighten with a screwdriver.

Connect the fan to the controller.

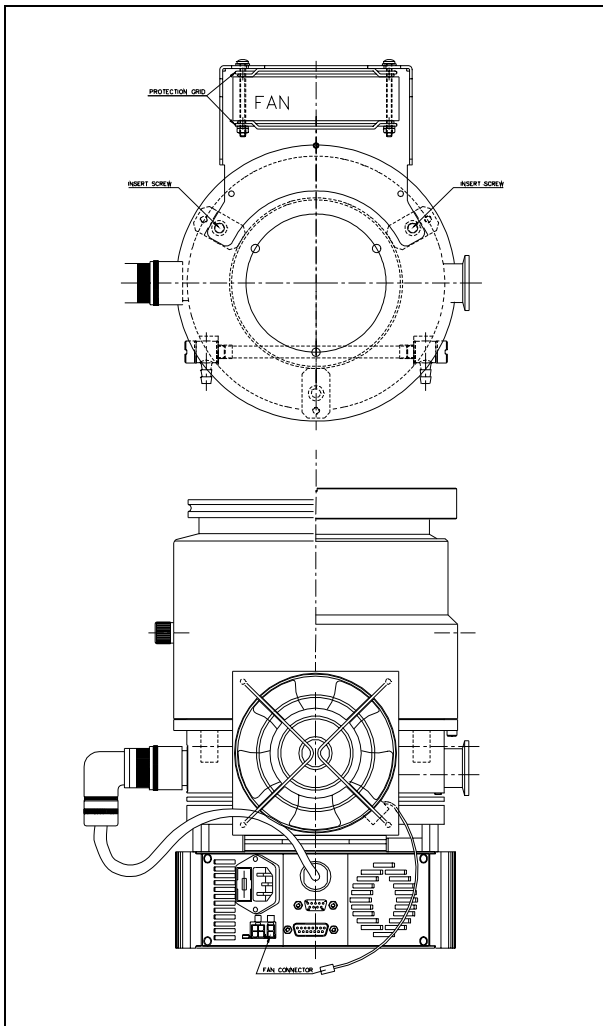

TV 551/701 Pump with Standard Rack Controller

When the TV 551/701 pumps are used with the standard rack controller, it is necessary to utilize the air cooling kit model 969-9314.

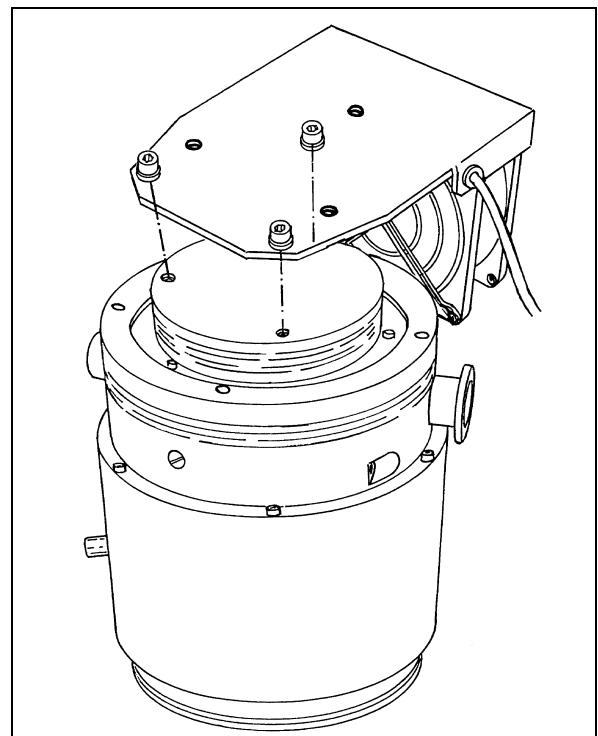

WATER COOLING KIT INSTALLATION

The water cooling kit mod. 969-9347 or 969-9337 must be installed when the pump is used under heavy load conditions or when air cooling is insufficient.

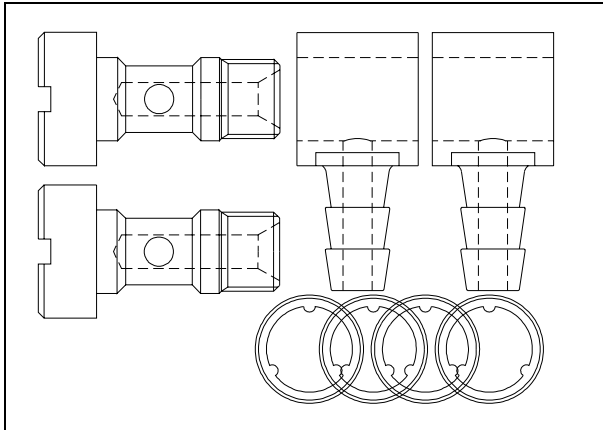

Model 969-9337

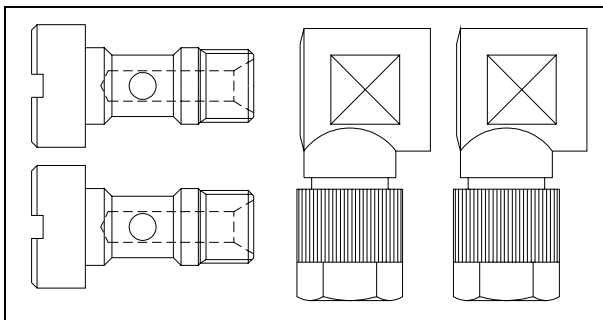

Model 969-9347

The kit is assembled as shown in the figure.

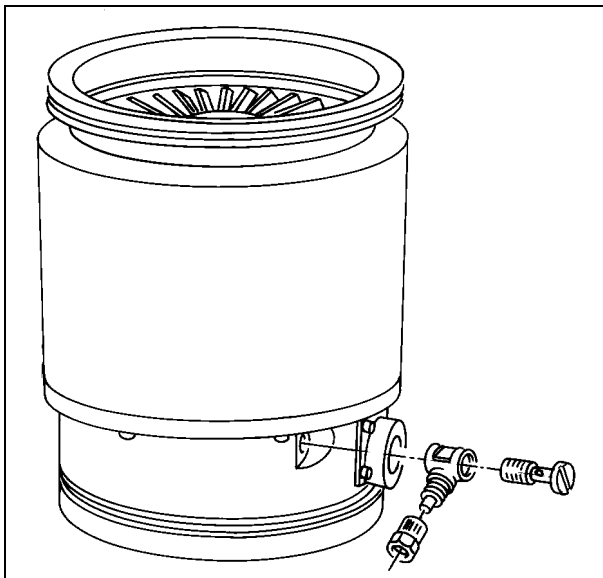

Two rubber or plastic hoses from the water supply must be fitted to the two water cooling banjos.

Cooling may be carried out either through an open circuit with eventual discharge of the water, or using a closed circuit cooling system.

The water temperature must be between +10°C and +30°C, with an inlet pressure between 3 and 5 bar. This allows a flow of about 200 l/h.

NOTE

The water electrical conductance must be $\leq 500 \mu\text{s/cm}$. When the conductance is higher, in closed water circuit, the use of up to 20% of Ethyl-Glycole is suggested.

VENT ACCESSORIES

The vent valve and vent device allow to avoid undesired venting of the pump during temporary power failure and enables an automatic vent operation.

TV 551/701 Navigator Controller Compatible Vent Valve mod. 969-9834

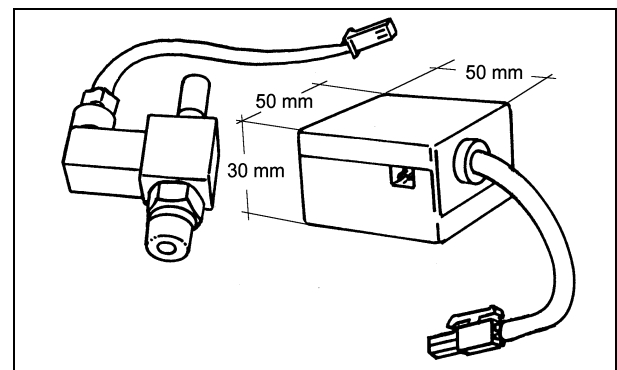

This vent valve waits before opening a minimum time of about 5 sec. This time can be increased up to about 220 min. by means of a setting of the Navigator software (optional).

To install the vent valve, unscrew the threaded plug (see figure below).

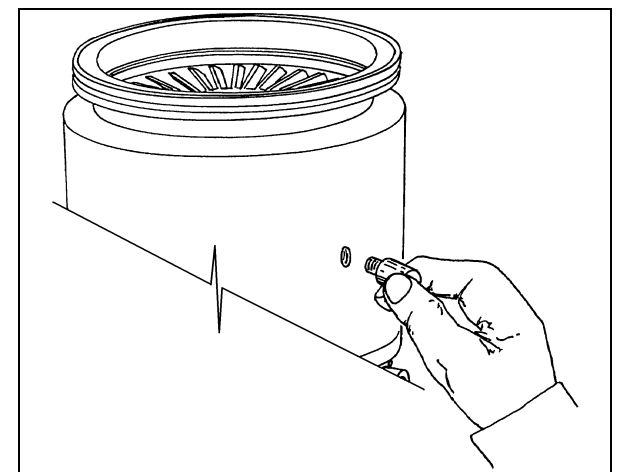

Then screw the vent valve into the pump and tighten it using a 16 mm hexagonal spanner with a torque of 2.5 Nm.

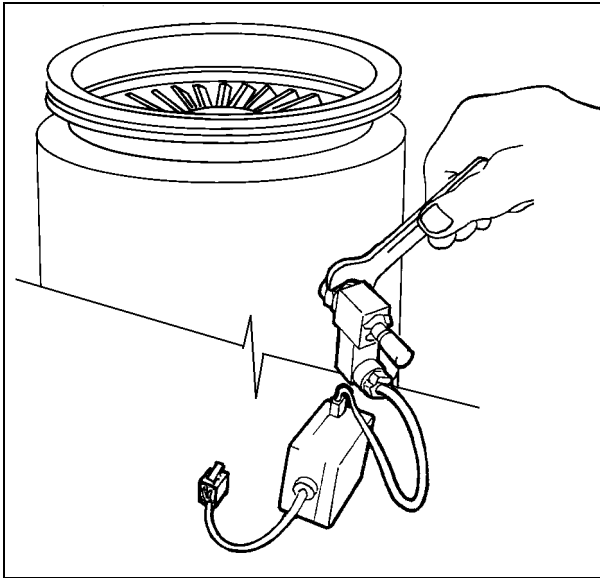

⚠ CAUTION

Do not overtighten the valve as this may damage the thread on the pump.

Then connect the cable from the valve to the suitable connector on the controller (see the preceding paragraph "INTERCONNECTIONS").

**Standard Rack Controller Compatible
Vent Valve mod. 969-9843**

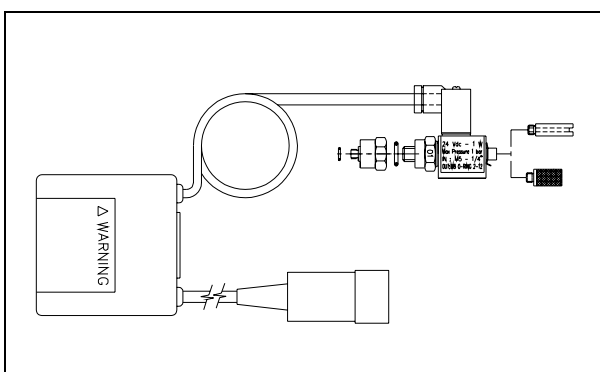

This vent valve has a fixed delay time of about 5 sec. This time can be increased up to about 220 min. by means of a setting of the Navigator software (optional).

To install the vent valve execute the same steps as the vent valve model 969-9834 (see the above paragraph).

Vent Device mod. 969-9831

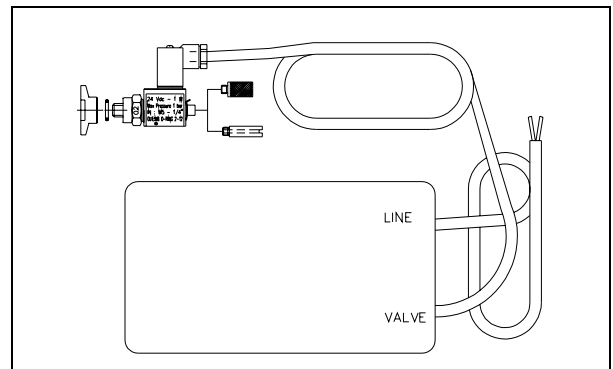

The vent device has adjustable delay time (up to 36 min.).

To install the vent device unscrew and remove the threaded plug (see figure below).

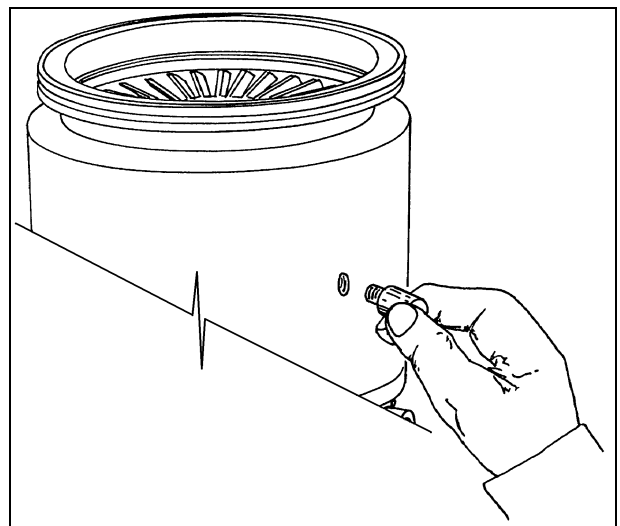

Screw the flange mod. 969-9108 on the pump, taking care of the o-ring right position.

Assemble the seal ring and lock the vent device in position using the KF klamp.

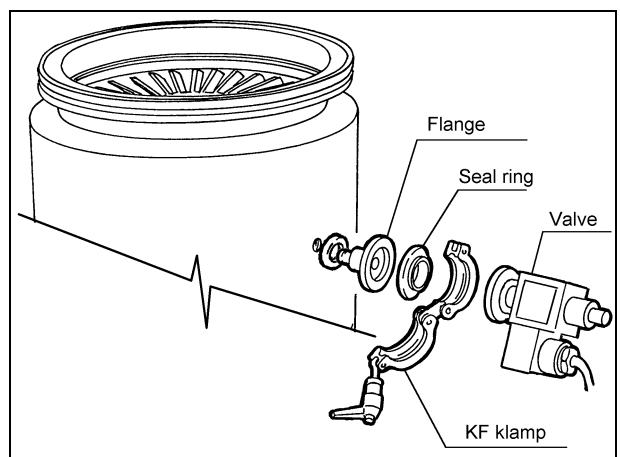

VIBRATION ISOLATOR INSTALLATION

Six vibration isolators for ISO and CFF inlet flange version pumps are available as accessories.

The four model part numbers are the following:

- model 969-9344 for ISO 100 flange;
- model 969-9345 for ISO 160 flange;
- model 969-9346 for ISO 200 flange;
- model 969-9334 for CFF 6" flange;
- model 969-9335 for CFF 8" flange;
- model 969-9336 for CFF 10" flange.

They typically reduce the vibration transmitted from the TV-551/701 Navigator to the system by a factor of 20.

Please refer to the relevant instruction manual.

PURGE VALVE INSTALLATION

A gas purge valve is available to protect the pump bearings against particulate and corrosive gases that could move into the pump.

To install the gas purge valve it is necessary to unscrew the purge port cover as shown in the following figure,

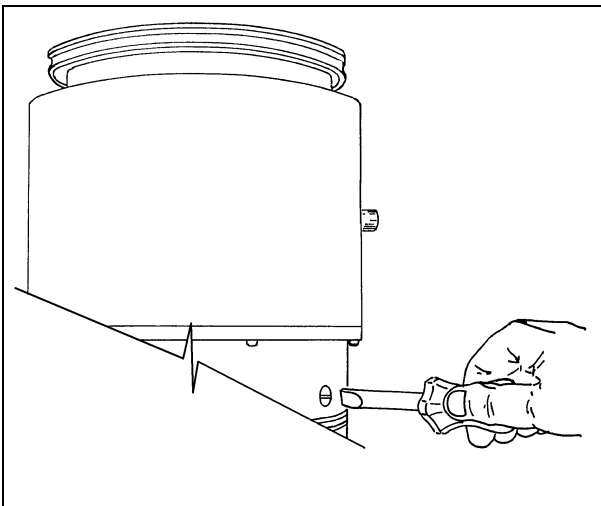

and then screw the gas purge valve (with a torque of 2.5 Nm) as shown in the following figure.

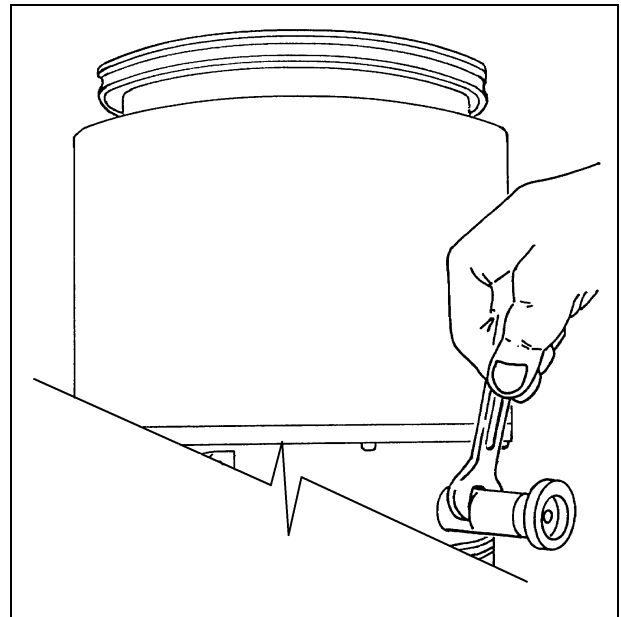

SERIAL CABLE INSTALLATION

The supplied serial cable must be installed when the TV 551/701 Navigator or the optional vent valve have to be controlled by means of a remote computer.

The cable is installed fixing the 9 pin D-type connector into the P2 serial connector as shown in the following figure.

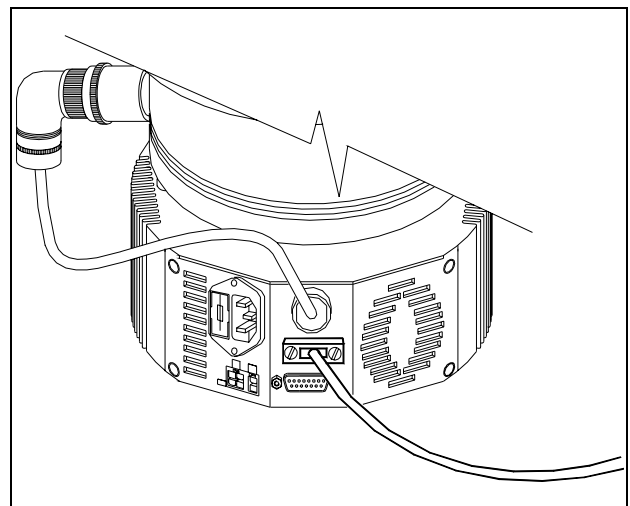

TV 551/701 CONTROLLER INSTALLATION

The controller can be mounted in two position:

- bottom mounting (as per the complete system)
- side mounting.

To install the controller execute the following procedures.

Bottom mounting

See the following figure.

1. Turn the pump upside-down;
2. Place the three fixing blocks with the through holes toward the inside, and fix them with the three M6 screws to the pump bottom;
3. Place the controller on the blocks, with the pump cable toward the pump body;
4. Fix the controller to the blocks by means of the three socket head screws M5;
5. Turn the pump again;
6. Plug the line card and connect the pump cable to the pump;
7. Connect the mating connector with the jumper on the interlock signal to start the pump.

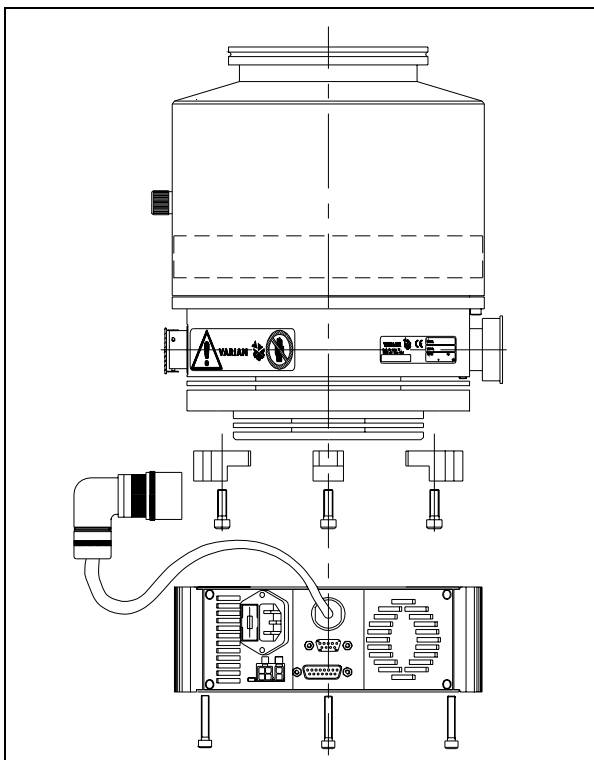

Side mounting

NOTE

The L-shaped bracket (P/N 969-9349) is available as an option.

See the following figure.

1. Place the L-shaped bracket on the controller, with the pump cable toward the bracket, and fix it by means of the three socket head screws M5, the washers and the nuts. The 6 holes on the bracket allows to mount the controller with the rotation angle that you like;
2. Turn the pump upside-down;
3. Place the bracket on the pump bottom (the hole on the bracket has the same diameter as the pump bottom flange);
4. Screw a little bit the three screws M6 in the holes on the pump bottom;
5. Rotate the bracket until the controller is on the chosen position;
6. Tighten the screws properly;
7. Turn the pump again;
8. Plug the line card and connect the pump cable to the pump;
9. Connect the mating connector with the jumper on the interlock signal to start the pump.

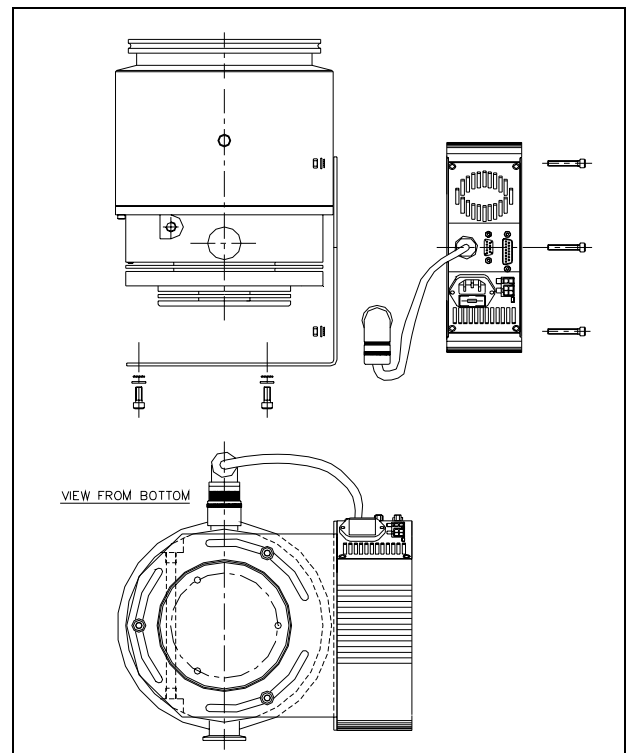

TYPICAL LAYOUT DIAGRAM

With Navigator Controller

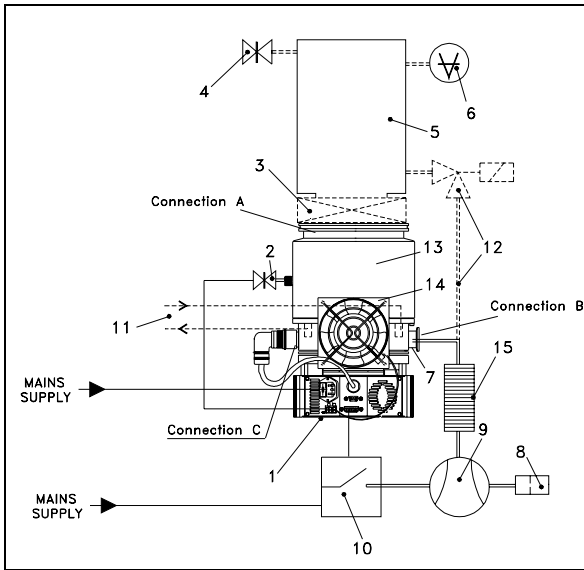

1. Turbo-V Navigator controller
2. Vent valve
3. Vacuum pump shut-off valve (optional)
4. System vent valve (optional)
5. Vacuum chamber
6. Ionization gauge
7. Fore-vacuum pump connecting flange
8. Oil mist eliminator
9. Fore-vacuum pump with internal one-way valve
10. Fore-vacuum pump control relay
11. Connection for water cooling
12. Roughing line with valve (optional)
13. Turbopump
14. Fan
15. Flexible connection

With Standard Rack Controller

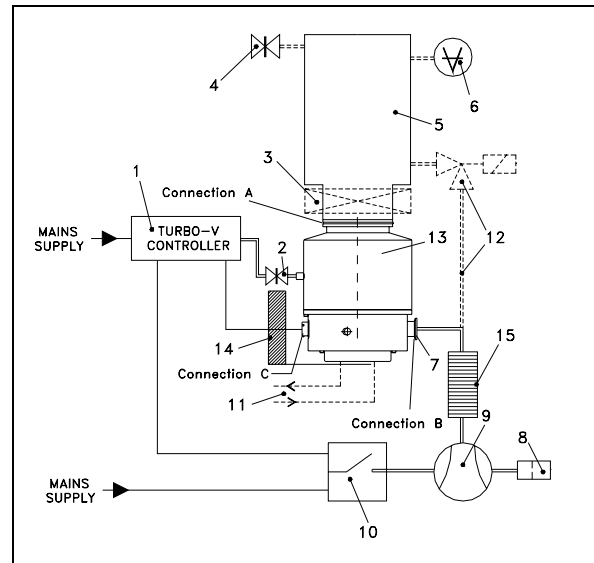

1. Turbo-V standard rack controller
2. Vent valve
3. Vacuum pump shut-off valve (optional)
4. System vent valve (optional)
5. Vacuum chamber
6. Ionization gauge
7. Fore-vacuum pump connecting flange
8. Oil mist eliminator
9. Fore-vacuum pump with internal one-way valve
10. Fore-vacuum pump control relay
11. Connection for water cooling
12. Roughing line with valve (optional)
13. Turbopump
14. Fan
15. Flexible connection

Connection A - HIGH VACUUM FLANGE

To connect the Turbo-V551/701 pump to the ISO inlet flange, remove the outer ring and position the centering ring as shown in the figure.

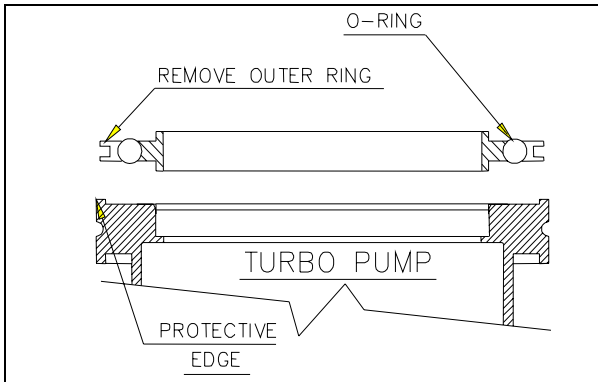

Then fix the two flanges with the clamps or claws as shown in the figure.

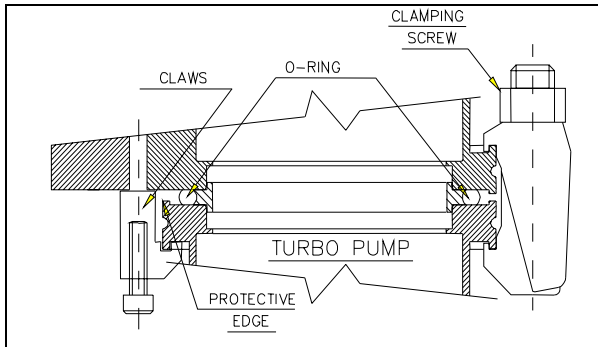

For ConFlat flange connections we recommend using Varian hardware.

To facilitate assembly and dismantling, apply Felpro C-100 high temperature lubricant to the screw threads protruding from the flange and between the nuts and flange.

Note that the connections can be made only with the bolt in the lower side.

Attach the units and tighten each one in turn. Repeat the sequential tightening until the flange faces meet.

CAUTION

Exercise care when tightening nuts and bolts to avoid creating dents in the envelope as this may cause the pump rotor to lock.

Connection configurations

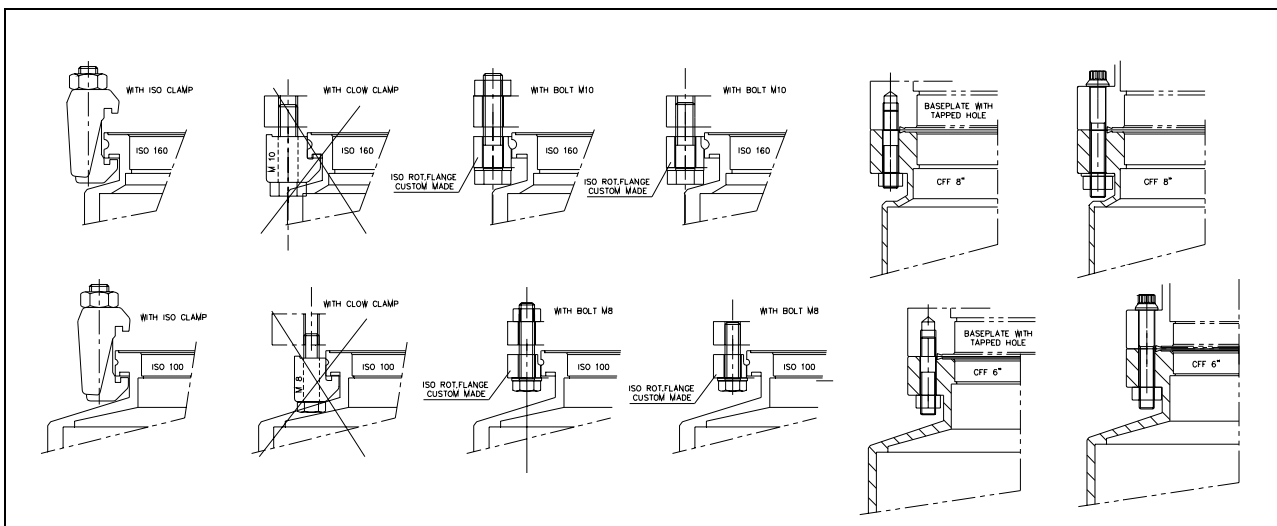

Connection B - FORE-VACUUM PUMP

A flange KF 25 NW is available to connect the Turbo-V551/701 pump to the fore-vacuum pump. A hose or vacuum approved pipe can be used. If a rigid pipe is used, any vibration generated by the mechanical pump must be eliminated through the use of bellows.

NOTE

The Turbo-V551/701 pump is characterized by its high compression ratio also for oil vapors. When using a mechanical oil-sealed pump, it is advisable to install a suitable trap between the turbopump and the fore-vacuum pump in order to prevent oil backstreaming.

Connection C - ELECTRICAL

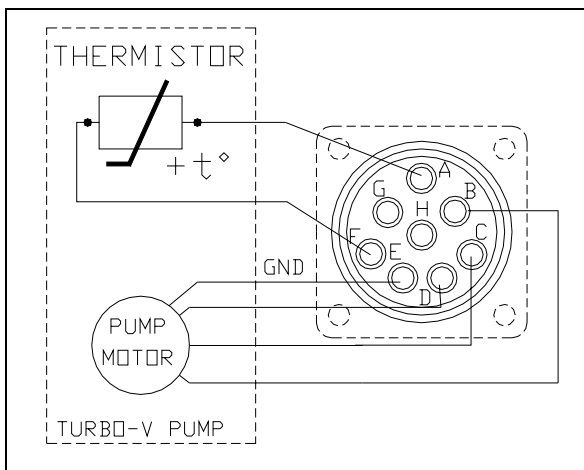

The turbopump is connected to the controller through an 8-pin connector. Pins B, C and D are the 3-phase supply to the motor, pins A and F are connected to the temperature sensor (NTC type, 30 KΩ resistance at 25° C) and pin E is connected to the pump ground; pins G and H are not connected.

If the temperature sensor is disconnected, the pump will not start. To prevent damage to the pump when the temperature exceeds 60° C, the sensor automatically cuts out the power supply.

PUMP USED WITH CORROSIVE GASES

To prevent damage to the bearings, an inert gas must flow into the pump body around the upper bearing towards the forevacuum line. To supply the inert purge gas (e. g. nitrogen) to the pump through the purge port, connect a gas purge valve between the pressure regulator and the pump.

Adjust the pressure regulator in order to read a gas flow rate of 0.1 to 0.8 mbar l/s.

CAUTION

To prevent bearing damage, Varian suggests a minimum purge gas flow rate of 10 sccm (0.17 mbar l/s). This value can be exceeded, according to the process requirements. Please contact Varian for specific applications.

The purge gas throughput with the recommended forepump of 15 m³ /h (11 CFM) allows to achieve a high vacuum pressure in the 10⁻⁸ mbar range.

The recommended gas flow maintains a pressure into the pump body higher than the forevacuum pressure. The recommended procedure to vent the system and the pump avoiding the contact between the pump bearings and the corrosive gas is described in the following points:

1. Close the corrosive gas flow into the system.
2. Leaving the Turbo-V pump and the backing pump running and the purge gas flowing, wait for enough time to evacuate the corrosive gas from the system.
3. Open the Turbo-V vent port slowly until to reach atmospheric pressure in the system.
4. Turn off the Turbopump.
5. When the Turbo-V pump and the backing pump are stopped and the system is at atmospheric pressure, for a better bearing protection it is advisable to leave the purge gas flowing into the Turbo-V pump, with the chamber or the Turbo-V vent valve opened, to avoid system overpressures. If the vent valve can't be kept opened, the backing pump should be left operating.

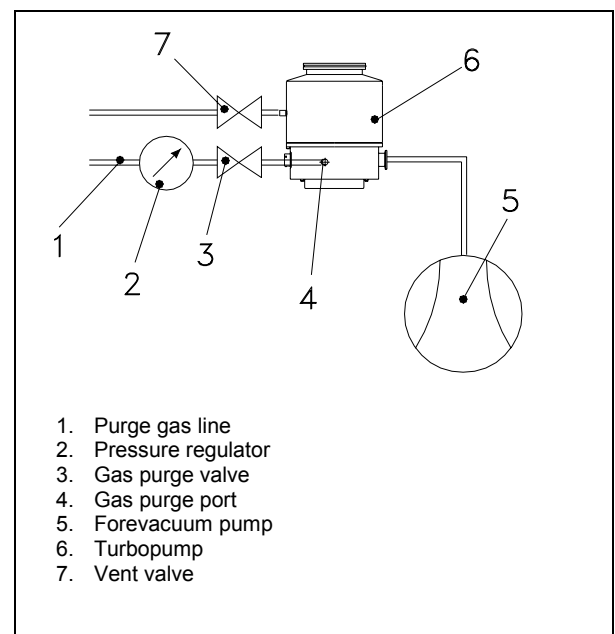

Purge layout

PUMP USED IN PRESENCE OF MAGNETIC FIELDS

Magnetic fields induce eddy currents in the rotor of a turbomolecular pump that tend to oppose to its rotation.

The result is increased electrical power consumption by the motor, most of which is dissipated in the rotor.

Since the rotor is not in contact with the stator the above power can leave the rotor mainly by radiation and hence the rotor may be overheated while static parts of the pump remain cool.

This effect is strongly dependant from the intensity, time function and distribution of the magnetic field.

In general, therefore, an increase in pump current can be expected.

If this increase is lower than 50% of the current value drawn by the motor in high vacuum operation, no particular problem should be expected.

However if the effect is grater, than the case should be carefully reviewed by Varian's specialist. As a matter of fact, in case of high magnetic fields, also important forces might be generated and applied to the rotor.

ACCESSORIES AND SPARE PARTS

DESCRIPTION	PART NUMBER
Mains cable NEMA Plug, 3m long	969-9958
Mains cable European Plug, 3m long	969-9957
Serial cable and Navigator Software	969-9883
Inlet screen DN 100	969-9302
Inlet screen DN 160	969-9304
Inlet screen DN 200	969-9316
Heater band, 220 V	969-9807
Heater band, 120 V	969-9808
Water cooling kit (plastic model)	969-9347
Water cooling kit (metallic model)	969-9337
Air cooling kit for Navigator Controller	969-9339
Air cooling kit for standard rack controller	969-9314
Bracket for Navigator Controller side mounting	969-9349
Vibration isolator, ISO 100	969-9344
Vibration isolator, CF 6"	969-9334
Vibration isolator, ISO 160	969-9345
Vibration isolator, CF 8"	969-9335
Vibration isolator, ISO 200	969-9346
Vibration isolator, CF 10"	969-9336
Vent flange, NW 10 KF / M8	969-9108
Vent device with adjustable delay time for standard rack controller	969-9831
Vent valve for standard rack controller	969-9843
Vent valve for Navigator Controller	969-9834
Purge valve with KF16 flange	969-9239
Purge valve with 7/16" flange	969-9240
Forepump DS 302, with 1 ph., universal motor	949-9325
Dry forevacuum pump MD 60, 120 V	949-9411
Dry forevacuum pump MD 60, 220 V	949-9412
Triscroll Dry Vacuum Pump PTS 300 single phase, universal motor	PTS03001UNIV
Triscroll Dry Vacuum Pump PTS 300 3 phase, universal motor	PTS03003UNIV



Request for Return



1. A Return Authorization Number (RA#) **WILL NOT** be issued until this Request for Return is completely filled out, signed and returned to Varian Customer Service.
2. Return shipments shall be made in compliance with local and international **Shipping Regulations** (IATA, DOT, UN).
3. The customer is expected to take the following actions to ensure the **Safety** of workers at Varian: (a) Drain any oils or other liquids, (b) Purge or flush all gasses, (c) Wipe off any excess residues in or on the equipment, (d) Package the equipment to prevent shipping damage, (for Advance Exchanges please use packing material from replacement unit).
4. Make sure the shipping documents clearly show the RA# and then return the package to the Varian location nearest you.

North and South America

Varian Vacuum Technologies
 121 Hartwell Ave
 Lexington, MA 02421
 Phone : +1 781 8617200
 Fax: +1 781 8609252

Europe and Middle East

Varian SpA
 Via Flli Varian 54
 10040 Leini (TO) – ITALY
 Phone: +39 011 9979111
 Fax: +39 011 9979330

Asia and ROW

Varian Vacuum Technologies
 Local Office

CUSTOMER INFORMATION

Company name:	
Contact person: Name:	Tel:
Fax:	E-Mail:
Ship Method:	Shipping Collect #: P.O.#:
<u>Europe only</u> : VAT reg. Number:	<u>USA only</u> : <input type="checkbox"/> Taxable <input type="checkbox"/> Non-taxable
Customer Ship To:	Customer Bill To:
.....
.....

PRODUCT IDENTIFICATION

Product Description	Varian P/N	Varian S/N	Purchase Reference

TYPE OF RETURN (check appropriate box)

<input type="checkbox"/> Paid Exchange	<input type="checkbox"/> Paid Repair	<input type="checkbox"/> Warranty Exchange	<input type="checkbox"/> Warranty Repair	<input type="checkbox"/> Loaner Return
<input type="checkbox"/> Credit	<input type="checkbox"/> Shipping Error	<input type="checkbox"/> Evaluation Return	<input type="checkbox"/> Calibration	<input type="checkbox"/> Other

HEALTH and SAFETY CERTIFICATION

Varian Vacuum Technologies **CAN NOT ACCEPT** any equipment which contains **BIOLOGICAL HAZARDS** or **RADIOACTIVITY**. Call Varian Customer Service to discuss alternatives if this requirement presents a problem.

The equipment listed above (check one):

HAS NOT been exposed to any toxic or hazardous materials

OR

HAS been exposed to any toxic or hazardous materials. In case of this selection, check boxes for any materials that equipment was exposed to, check all categories that apply:

- Toxic Corrosive Reactive Flammable Explosive Biological Radioactive

List all toxic or hazardous materials. Include product name, chemical name and chemical symbol or formula.

.....

Print Name: Customer Authorized Signature:

Print Title: Date:/...../.....

NOTE: If a product is received at Varian which is contaminated with a toxic or hazardous material that was not disclosed, **the customer will be held responsible** for all costs incurred to ensure the safe handling of the product, and **is liable** for any harm or injury to Varian employees as well as to any third party occurring as a result of exposure to toxic or hazardous materials present in the product.

Do not write below this line

Notification (RA)#: Customer ID#: Equipment #:

FAILURE REPORT

TURBO PUMPS and TURBOCONTROLLERS

<input type="checkbox"/> Does not start <input type="checkbox"/> Does not spin freely <input type="checkbox"/> Does not reach full speed <input type="checkbox"/> Mechanical Contact <input type="checkbox"/> Cooling defective	<input type="checkbox"/> Noise <input type="checkbox"/> Vibrations <input type="checkbox"/> Leak <input type="checkbox"/> Overtemperature	POSITION <input type="checkbox"/> Vertical <input type="checkbox"/> Horizontal <input type="checkbox"/> Upside-down <input type="checkbox"/> Other:	PARAMETERS Power: Rotational Speed: Current: Inlet Pressure: Temp 1: Foreline Pressure: Temp 2: Purge flow:
TURBOCONTROLLER ERROR MESSAGE:			OPERATION TIME:

ION PUMPS/CONTROLLERS

<input type="checkbox"/> Bad feedthrough <input type="checkbox"/> Vacuum leak <input type="checkbox"/> Error code on display	<input type="checkbox"/> Poor vacuum <input type="checkbox"/> High voltage problem <input type="checkbox"/> Other
Customer application:	

VALVES/COMPONENTS

<input type="checkbox"/> Main seal leak <input type="checkbox"/> Solenoid failure <input type="checkbox"/> Damaged sealing area	<input type="checkbox"/> Bellows leak <input type="checkbox"/> Damaged flange <input type="checkbox"/> Other
Customer application:	

LEAK DETECTORS

<input type="checkbox"/> Cannot calibrate <input type="checkbox"/> Vacuum system unstable <input type="checkbox"/> Failed to start	<input type="checkbox"/> No zero/high background <input type="checkbox"/> Cannot reach test mode <input type="checkbox"/> Other
Customer application:	

INSTRUMENTS

<input type="checkbox"/> Gauge tube not working <input type="checkbox"/> Communication failure <input type="checkbox"/> Error code on display	<input type="checkbox"/> Display problem <input type="checkbox"/> Degas not working <input type="checkbox"/> Other
Customer application:	

PRIMARY PUMPS

<input type="checkbox"/> Pump doesn't start <input type="checkbox"/> Doesn't reach vacuum <input type="checkbox"/> Pump seized	<input type="checkbox"/> Noisy pump (describe) <input type="checkbox"/> Over temperature <input type="checkbox"/> Other
Customer application:	

DIFFUSION PUMPS

<input type="checkbox"/> Heater failure <input type="checkbox"/> Doesn't reach vacuum <input type="checkbox"/> Vacuum leak	<input type="checkbox"/> Electrical problem <input type="checkbox"/> Cooling coil damage <input type="checkbox"/> Other
Customer application:	

FAILURE DESCRIPTION

(Please describe in detail the nature of the malfunction to assist us in performing failure analysis):

NOTA: Su richiesta questo documento è disponibile anche in Tedesco, Italiano e Francese.
REMARQUE : Sur demande ce document est également disponible en allemand, italien et français.
HINWEIS: Auf Anfrage ist diese Unterlage auch auf Deutsch, Italienisch und Französisch erhältlich.

Sales and Service Offices

Argentina **Varian Argentina Ltd.**

Sucursal Argentina
Av. Ricardo Balbin 2316
1428 Buenos Aires
Argentina
Tel: (54) 1 783 5306
Fax: (54) 1 786 5172

Australia **Varian Australia Pty Ltd.**

679-701 Springvale Road
Mulgrave, Victoria ZZ 3170
Australia
Tel: (61) 395607133
Fax: (61) 395607950

Benelux **Varian Vacuum Technologies**

Rijksstraatweg 269 H,
3956 CP Leersum
The Netherlands
Tel: (31) 343 469910
Fax: (31) 343 469961

Brazil **Varian Industria e Comercio Ltda.**

Avenida Dr. Cardoso de Mello 1644
Vila Olimpia
Sao Paulo 04548 005
Brazil
Tel: (55) 11 3845 0444
Fax: (55) 11 3845 9350

Canada **Central coordination through:**

Varian Vacuum Technologies
121 Hartwell Avenue
Lexington, MA 02421
USA
Tel: (781) 861 7200
Fax: (781) 860 5437
Toll Free: (800) 882 7426

China **Varian Technologies - Beijing**

Room 1201, Jinyu Mansion
No. 129A, Xuanwumen Xidajie
Xicheng District
Beijing 1000031 P.R. China
Tel: (86) 10 6608 1530
Fax: (86) 10 6608 1534

France and Wallonie **Varian s.a.**

7 avenue des Tropiques
Z.A. de Courtaboeuf – B.P. 12
Les Ulis cedex (Orsay) 91941
France
Tel: (33) 1 69 86 38 13
Fax: (33) 1 69 28 23 08

Germany and Austria **Varian Deutschland GmbH**

Alsfelder Strasse 6
Postfach 11 14 35
64289 Darmstadt
Germany
Tel: (49) 6151 703 353
Fax: (49) 6151 703 302

India **Varian India PVT LTD**

101-108, 1st Floor
1010 Competent House
7, Nangal Raya Business Centre
New Delhi 110 046
India
Tel: (91) 11 5548444
Fax: (91) 11 5548445

Italy **Varian Vacuum Technologies**

Via F.lli Varian, 54
10040 Leini, (Torino)
Italy
Tel: (39) 011 997 9111
Fax: (39) 011 997 9350

Japan **Varian Vacuum Technologies**

Sumitomo Shibaura Building, 8th Floor
4-16-36 Shibaura
Minato-ku, Tokyo 108
Japan
Tel: (81) 3 5232 1253
Fax: (81) 3 5232 1263

Korea **Varian Technologies Korea, Ltd.**

Shinsa 2nd Bldg. 2F
966-5 Daechi-dong
Kangnam-gu, Seoul
Korea 135-280
Tel: (82) 2 3452 2452
Fax: (82) 2 3452 2451

Mexico **Varian S.A.**

Concepcion Beistegui No 109
Col Del Valle
C.P. 03100
Mexico, D.F.
Tel: (52) 5 523 9465
Fax: (52) 5 523 9472

Taiwan **Varian Technologies Asia Ltd.**

18F-13 No.79, Hsin Tai Wu Road
Sec. 1, Hsi Chih
Taipei Hsien
Taiwan, R.O.C.
Tel: (886) 2 2698 9555
Fax: (886) 2 2698 9678

UK and Ireland **Varian Ltd.**

28 Manor Road
Walton-On-Thames
Surrey KT 12 2QF
England
Tel: (44) 1932 89 8000
Fax: (44) 1932 22 8769

United States **Varian Vacuum Technologies**

121 Hartwell Avenue
Lexington, MA 02421
USA
Tel: (781) 861 7200
Fax: (781) 860 5437
Toll Free: (800) 882 7426

Other Countries **Varian Vacuum Technologies**

Via F.lli Varian, 54
10040 Leini, (Torino)
Italy
Tel: (39) 011 997 9111
Fax: (39) 011 997 9350

Internet Users:

Customer Service & Technical Support:
vtt.customer.service@varianinc.com

Worldwide Web Site:
www.varianinc.com/vacuum

Order On-line:
www.evarian.com

Representatives in most countries



VARIAN