

TRIVAC

Rotary Vane Vacuum Pumps, Oil-Sealed;
1.5 to 65 m³ x h⁻¹ (0.7 to 38.3 cfm)

S 1,5, Single-Stage

TRIVAC E, Two-Stage

TRIVAC B, Two-Stage

171.01.02

Excerpt from the Oerlikon Leybold Vacuum Full Line Catalog

Product Section C01

Edition October 2010

Contents

General

Applications and Accessories C01.03

Products

Small Compact Pump S 1,5 C01.04

**TRIVAC D 2,5 E,
Two-Stage, Vane Vacuum Pump** C01.06

TRIVAC B, Two-Stage Rotary Vane Vacuum Pumps C01.10

TRIVAC D 4 B and D 8 B C01.12

TRIVAC D 16 B and D 25 B C01.16

TRIVAC D 40 B and D 65 B C01.20

TRIVAC D 16 B-DOT C01.24

TRIVAC D 16 B-Ex
(Explosion Protected and Pressure Burst Resistant) C01.26

TRIVAC BCS, Two-Stage Rotary Vane Vacuum Pumps C01.28

TRIVAC D 16 BCS to D 65 BCS C01.30

TRIVAC D 16 BCS-PFPE to D 65 BCS-PFPE C01.34

Motor Dependant Data for the TRIVAC B, BCS and BCS-PFPE . C01.38

Accessories

Exhaust Filter Drain Tap. C01.44

Oil Drain Tap C01.44

Oil Drain Kit. C01.44

Oil Suction Facility AR-V Controlled by Solenoid Valve C01.45

Manually Operated Oil Suction Facility AR-M C01.45

Exhaust Filters AF 8 to AF 25 C01.46

Condensate Traps AK 8 to AK 25. C01.46

AR 4-8, AR 16-25, AR 40-65 C01.48

Exhaust Filters with Lubricant Return
ARS 16-25 and ARS 40-65 C01.49

Exhaust Filters with Lubricant Return ARP 4-8,
Exhaust Filters AF 4-8, AF 16-25, AF 40-65 C01.50

Condensate Separators AK 4-8, AK 16-25, AK 40-65 C01.52

Dust Filters FS 2-4, FS 8-16, FS 30-60. C01.53

Dust Separators AS 8-16 and AS 30-60. C01.54

Molecular Filters MF 8-16 and MF 30-60 C01.54

Cold Trap TK 4-8 C01.56

Fine Vacuum Adsorption Traps FA 2-4, FA 8-16, FA 30-60. C01.57

Mechanical Oil Filters OF 4-25 and OF 40-65 C01.58

Chemical Oil Filters CF 4-25 and CF 40-65. C01.58

Chemical Filters with Safety Isolation Valve
CFS 16-25 and CFS 40-65. C01.60

Inert Gas System IGS 16-25 and IGS 40-65. C01.61

Limit Switch System LSS 16-25 and LSS 40-65. C01.62

Roots Pump Adaptor C01.63

OF1000 Oil Filtering System C01.64

RST Refillable Traps C01.68

SE Smoke Eliminator. C01.69

Compact Oil Mist Exhaust Filters. C01.80

General Accessories

Flange Components, Valves C01.71

Miscellaneous

Vacuum Pump Oils C01.72

Services C01.80

60 Hz Curves C01.84



S 1,5

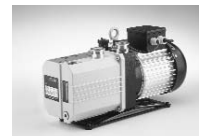

TRIVAC E

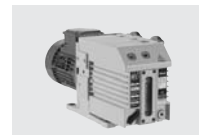

TRIVAC B



TRIVAC B-Ex



TRIVAC BCS

General

Applications and Accessories

Pumps	Pumps															
	S 1.5	TRIVAC D 2.5 E	TRIVAC D 4 B	TRIVAC D 8 B / TRIVAC NT 5	TRIVAC D 16 B / TRIVAC NT 10	TRIVAC D 25 B / TRIVAC NT 16	TRIVAC D 40 B	TRIVAC D 65 B	TRIVAC D 16 B-DOT / NT 16-DOT	TRIVAC D 16 B-Ex	TRIVAC D 16 BCS, D 25 BCS	TRIVAC D 40 BCS	TRIVAC D 65 BCS	TRIVAC D 16 + D 25 BCS-PFPE	TRIVAC D 40 BCS-PFPE	TRIVAC D 65 BCS-PFPE
Applications																
Production of semiconductors																
Vacuum coating																
Research and development																
Chemistry/pharmaceuticals																
Metallurgy/furnaces																
Lamps and tubes manufacture																
Car industry																
Laser engineering																
Space simulation																
Analytical engineering																
Environment engineering																
Cooling and air-conditioning																
Electrical engineering																
Mechanical engineering																
Medicine technology																
Vacuum drying cabinets																
Chemistry and research labs																
Freeze drying systems																
Backing pump for high vacuum pump systems																

Accessories

Page

Exhaust filter drain tap	C01.44															
Oil drain tap	C01.44															
Oil drain kit	C01.44															
Oil suction facility ¹⁾ AR-V	C01.45															
Oil suction facility ¹⁾ AR-M	C01.45															
Exhaust filters AF	C01.46/50															
Condensate traps / separators AK	C01.46/52															
Exhaust filters with lubricant return ARP / AR	C01.48															
Exhaust filters with lubricant return ARS	C01.49															
Dust filters FS	C01.53															
Dust separators AS	C01.54															
Molecular filters MF	C01.54															
Cold trap TK	C01.56															
Fine vacuum adsorption traps FA	C01.57															
Mechanical oil filters OF	C01.58															
Chemical oil filters CF	C01.58															
Chemical filters with safety isolation valve CFS	C01.60															
Inert gas system IGS	C01.61															
Limit switch system LSS	C01.62															
Roots pump adaptor	C01.63															
Flange components, valves	C01.71															
Vacuum pump oils	C01.72															

¹⁾ For pumps with gas ballast only

Products

Small Compact Pump S 1,5

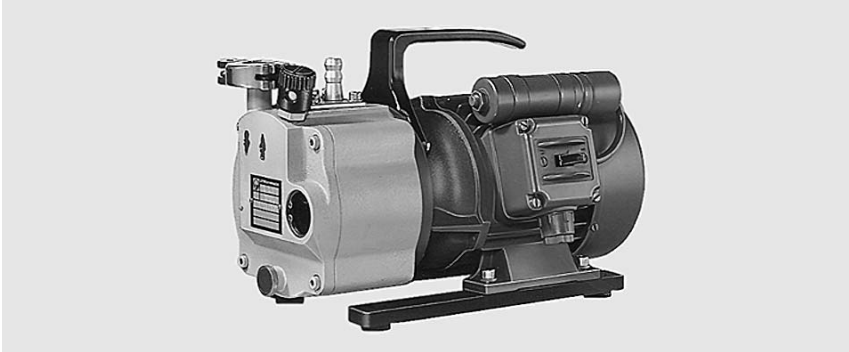

The S 1,5 is a single-stage, oil-sealed rotary vane pump with a gas ballast valve. It is driven by a flange mounted AC motor. The shaft of the pump and the shaft of the motor are linked by means of a pinned coupling.

Advantages to the User

- Very small and light-weight
- Low ultimate pressure
- High water vapor tolerance
- Low noise operation
- Simple to connect
- Easy to maintain and use

Typical Applications

- In all areas of vacuum engineering where a low intake pressure is required
- Evacuation of refrigerant circuits
- For suction, lifting, emptying, filling and tensioning
- For installation in mobile instruments

Supplied Equipment

- DN 16 small flange connection on the intake side
- Centering ring and clamping ring
- Exhaust port designed as a DN 6 hose nozzle
- Carrying handle
- Built-in ON/OFF switch and overcurrent circuit breaker
- Oil filling

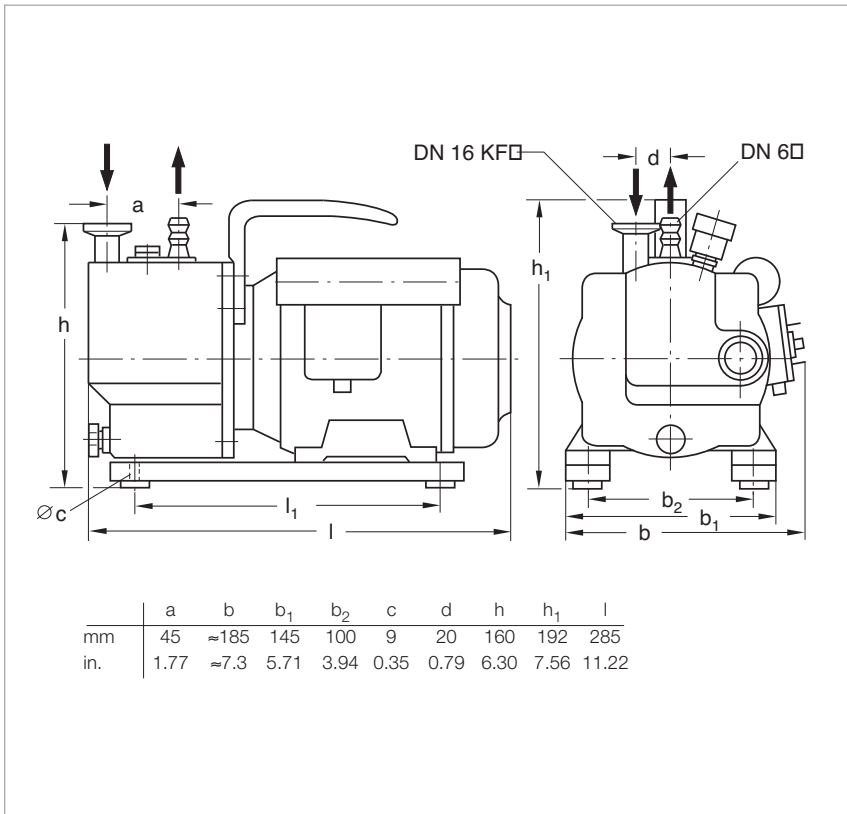

Dimensional drawing for the S 1,5

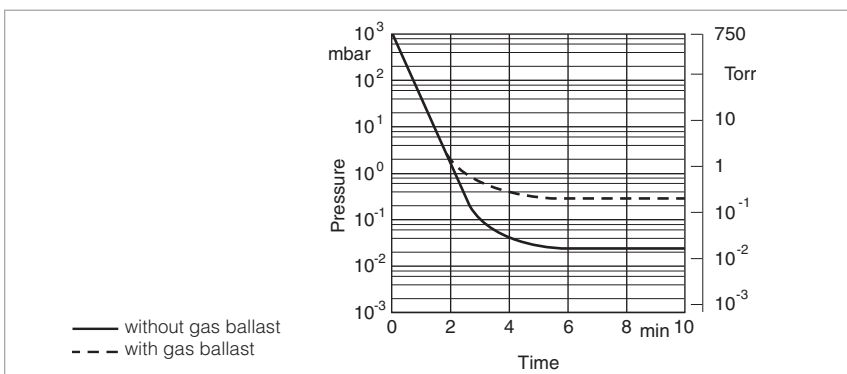

Pump-down characteristics of a 10 l vessel at 50 Hz

Technical Data

S 1,5

		50 Hz	60 Hz
Nominal pumping speed ¹⁾	m ³ /h (cfm)	1.9 (1.1)	2.3 (1.3)
Pumping speed ¹⁾	m ³ /h (cfm)	1.75 (1)	2.1 (1.2)
Ultimate partial pressure without gas ballast ¹⁾	mbar (Torr)	3 x 10 ⁻² (2.3 x 10 ⁻²)	3 x 10 ⁻² (2.3 x 10 ⁻²)
Ultimate total pressure with gas ballast ¹⁾	mbar (Torr)	5 x 10 ⁻¹ (3.8 x 10 ⁻¹)	5 x 10 ⁻¹ (3.8 x 10 ⁻¹)
Water vapor tolerance ¹⁾	mbar (Torr)	> 15 (> 11.3)	> 15 (> 11.3)
Water vapor capacity	g/h (lbs/h)	19 (42)	19 (42)
Oil filling, min. / max.	l (qt)	0.11 (0.14)	0.11 (0.14)
Admissible ambient temperature	°C (°F)	40 (104)	40 (104)
Motor rating	W (hp)	80 (0.11)	80 (0.11)
Nominal speed	rpm	1500	1800
Weight	kg (lbs)	10 (22.1)	10 (22.1)
Connections			
Intake	DN	16 KF	16 KF
Exhaust		6 mm hose	6 mm hose

Ordering Information

S 1,5

S 1,5 with AC motor, 230 V (208 - 252 V ± 5%), 50/60 Hz, with 2 m long mains cord and EURO plug	Part No. 101 01
Transition connector (250 V AC, 10 A, L+N+PE) only necessary in Switzerland for 1~ pumps	Part No. 800 001 274
AK 8 condensate trap	Part No. 190 60
Exhaust filter drain tap (G 1/4")	Part No. 190 95
Connection components Elbow (1x) DN 16 KF Centering ring with O-ring (2x) DN 16 KF Clamping ring (2x) DN 16 KF	Part No. 184 36 Part No. 183 26 Part No. 183 41

¹⁾ To DIN 28 400 and following numbers

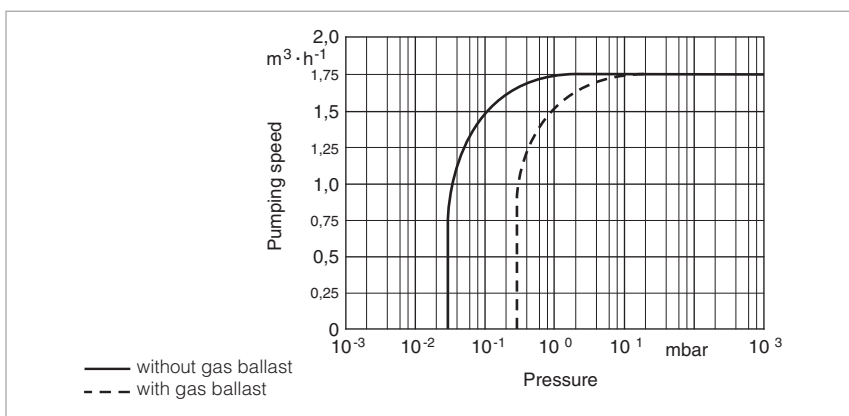

Pumping speed characteristics at 50 Hz

TRIVAC E, Two-Stage, Oil-Sealed Rotary Vane Vacuum Pump



TRIVAC D 2,5 E

The TRIVAC E pump is an oil-sealed vacuum pump operating according to the rotary vane principle. Oil which is injected into the pump chamber is used for sealing, lubrication and cooling purposes.

New customers' requirements as well as increased environmental requirements gave rise to the further development of the successful range of TRIVAC B pumps.

The result is the TRIVAC E rotary vane vacuum pump.

Beyond the usual quality and reliability of the B series pumps, the TRIVAC E pump offers improvements in the area of quieter operation, smaller size and improved service-friendliness.

The intake and exhaust ports are equipped with small flanges. Besides standard voltages and frequencies, Oerlikon Leybold Vacuum offers world motors, which are specially required by OEMs.

The TRIVAC E pump includes also a set of accessories which also fit the TRIVAC D 4 - 16 B pumps.

Advantages to the User

- Highly reliable
- Small and compact
- Quiet operation
- Environmentally compatible (low oil consumption, EMI compatible; IP 54 protection)
- Process quality (low backstreaming of oil)
- Motors for all standard supply voltages and frequencies
- Safe and intelligent vacuum protection (hermetically sealed)
- Free of yellow metals
- Compliance with international standards (CE and CSA)
- Suitable for continuous operation at 1000 mbar (750 Torr)
- Low power consumption
- Better individual performance given by 3 stage gas ballast device
- High water vapor tolerance
- Simplified customizing ability

Typical Applications

- Mass and X-ray spectrometers
- Leak detectors
- Electron beam microscopes
- Sterilizers
- Freeze-drying systems
- Chemical and research labs
- General vacuum engineering
- Backing pump for high vacuum pump systems

Supplied Equipment

- Dirt trap
- Oil filling included separately (standard N 62; HE-200 in the U.S.)
- Gas ballast device
- Mains cord with the specific plug for EURO, US and Japan motors
- Optional: Mains cord with country specific plug for the world motor
- With handle

All pumps are 100% subjected to a vacuum test before delivery!

TRIVAC D 2,5 E

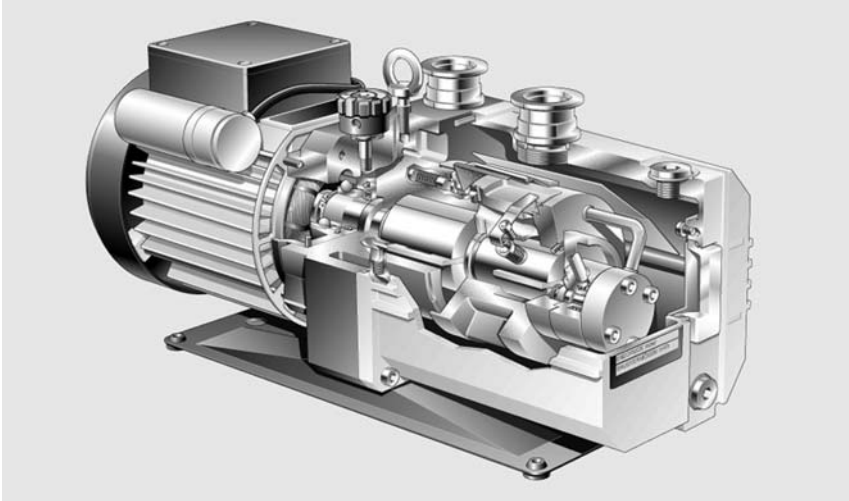

TRIVAC E

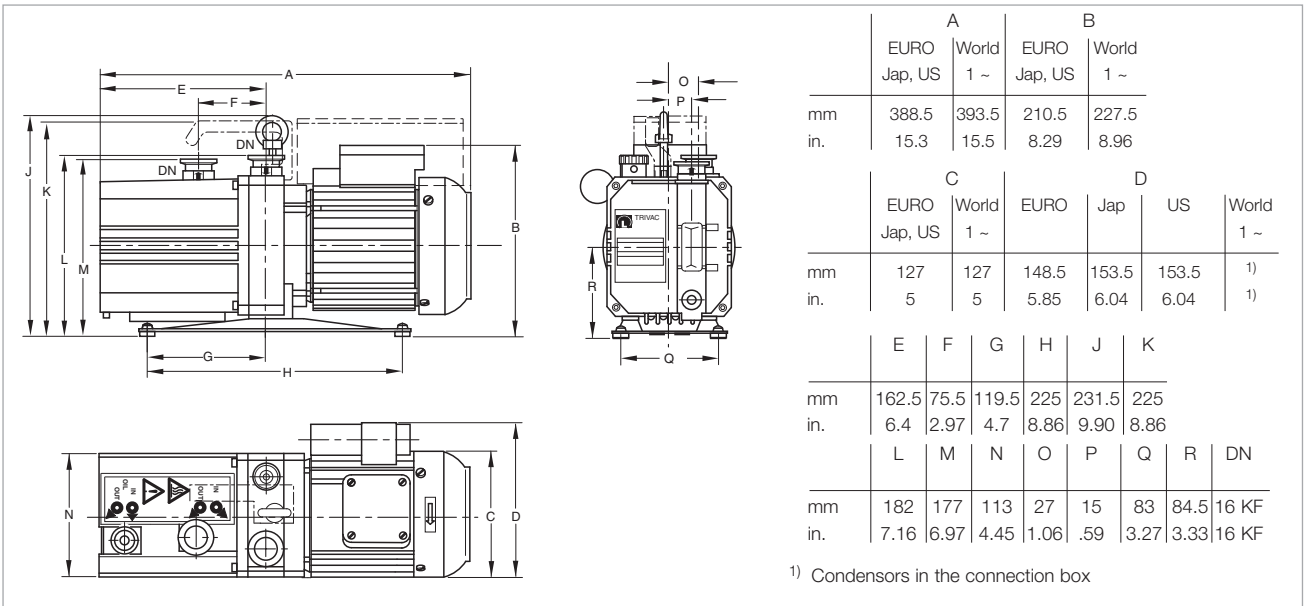

Dimensional drawing for the TRIVAC D 2,5 E

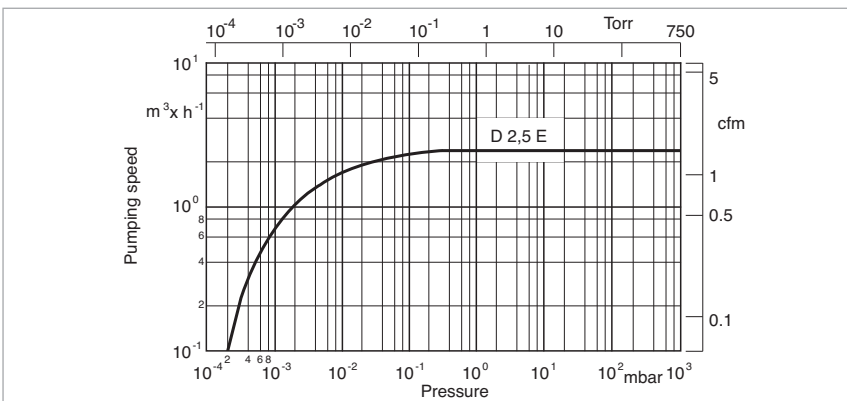

Pumping speed of the TRIVAC D 2,5 E at 50 Hz (60 Hz curves at the end of the section)

Technical Data

TRIVAC D 2,5 E

		50 Hz	60 Hz
Nominal pumping speed ¹⁾	m ³ /h (cfm)	3.2 (1.9)	3.6 (2.1)
Pumping speed ¹⁾	m ³ /h (cfm)	2.7 (1.6)	3.3 (1.9)
Ultimate partial pressure without gas ballast	mbar (Torr)	≤ 5 × 10 ⁻⁴ (≤ 3.8 × 10 ⁻⁴)	≤ 5 × 10 ⁻⁴ (≤ 3.8 × 10 ⁻⁴)
Ultimate total pressure without gas ballast ²⁾	mbar (Torr)	≤ 2 × 10 ⁻³ (≤ 1.5 × 10 ⁻³)	≤ 2 × 10 ⁻³ (≤ 1.5 × 10 ⁻³)
Ultimate total pressure with gas ballast Step 2 ²⁾	mbar (Torr)	≤ 3 × 10 ⁻² (≤ 2.3 × 10 ⁻²)	≤ 3 × 10 ⁻² (≤ 2.3 × 10 ⁻²)
Water vapor tolerance			
Step 1	mbar (Torr)	10 (7.5)	10 (7.5)
Step 2	mbar (Torr)	20 (15)	20 (15)
Step 3	mbar (Torr)	30 (22.5)	30 (22.5)
Water vapor capacity			
Step 1	g/h	20	20
Step 2	g/h	40	40
Step 3	g/h	60	60
Oil filling, max. / min.	l (qt)	0.7 / 0.4 (0.7 / 0.4)	0.7 / 0.4 (0.7 / 0.4)
Noise level	dB(A)	≤ 47	≤ 47
Admissible ambient temperature	°C (°F)	+10 to +50 (+50 to +122) (EURO motor) / +10 to +40 (+50 to +104) (US/Japan motor)	+10 to +50 (+50 to +122) (EURO motor) / +10 to +40 (+50 to +104) (US/Japan motor)
Motor rating 50/60 Hz	W (HP)	250 (0.34)	300 (0.41)
Nominal speed 50/60 Hz	rpm	1400	1600
Type of protection	IP	54	54
Weight (with oil filling)	kg (lbs)	15.3 (33.7)	15.3 (33.7)
Dimensions (W x H x D)	mm (in.)	127 x 225 x 383 (5 x 8.86 x 15)	127 x 225 x 383 (5 x 8.86 x 15)
Connections (Intake and Exhaust)	DN	16 KF	16 KF

¹⁾ To DIN 28 426 T1

²⁾ To DIN 28 400 and following numbers

Motor Dependent Data

Motors for D 2,5 E	Voltage (V)	Frequency (Hz)	Voltage tolerance	Power consumption (W (HP))	Nominal current (A)	Protection	Nominal speed (rpm)
EURO 1 ~	220-240/230	50/60	± 5%	250/300 (0.34/0.41)	1.8/1.4	IP 54	1400/1600
Japan 1 ~	100	50/60	± 5%	250/300 (0.34/0.41)	5.5/4.0	IP 54	1400/1600
US 1 ~	110-120	60	± 5%	300 (0.41)	3.3	IP 54	1600
World 1 ~	100-120; 200-240	50/60	± 5%	250/300 (0.34/0.41)	4.4/3.0 2.2/1.5	IP 54	1400/1600

Ordering Information

TRIVAC D 2,5 E

TRIVAC E with 1.8 m (6 ft.) long mains cord EURO version, 1-ph., 220-240 V, 50 Hz; 230 V, 60 Hz Earthed plug	Part No. 140 000
UK plug	Part No. 140 004
CH plug	Part No. 140 005
US version, 1-ph., 110-120 V, 60 Hz, NEMA plug	Part No. 140 002
Japan version, 1-ph., 100 V, 50/60 Hz, NEMA plug	Part No. 140 003
Single phase world motor, 100-120 V, 200-240 V 50/60 Hz (without mains cord)	Part No. 140 001
Further variants upon request	
Accessories	
Connection cable for single phase world motor 230 V earthed plug 230 V UK plug 230 V CH plug 230 V NEMA plug (200-240 V) 115 V NEMA plug (100-120 V)	Part No. 200 81 091 Part No. 200 81 097 Part No. 200 81 099 Part No. 200 81 141 Part No. 200 81 090
Exhaust filter AF 8	Part No. 190 50
Replacement filter elements FE 8 for AF 8 (pack of 5)	Part No. 190 80
Exhaust filter drain tap (G 1/4")	Part No. 190 95
Manual oil return AR-M via gas ballast inlet (kit for AF 8-16)	Part No. 190 93
Oil suction AR-V controlled by a solenoid valve via the gas ballast inlet (kit for AF 8-16)	Part No. 190 92
Condensate trap AK 8	Part No. 190 60
Oil drain tap (M 16 x 1.5)	Part No. 190 90
Oil drain kit (M 16 x 1.5)	Part No. 190 94
Connection components Elbow (1x) DN 16 KF Centering ring with O-ring (2x) DN 16 KF Clamping ring (2x) DN 16 KF	Part No. 184 36 Part No. 183 26 Part No. 183 41
Spare Parts	
Maintenance kit 1 (oil demister, oil box seal)	Part No. 200 40 022
Repair kit 1 (motor side sealing, shaft sealing ring, coupling sleeves, compression spring)	Part No. E 100 000 351
Repair kit 2 (valves, oil demister, oil box seal)	Part No. 200 40 024
Repair kit 3 (oil demister, sealing, wearing parts)	Part No. E 100 000 347
For further accessories see Section "Accessories for TRIVAC E, NT, B and BCS"	

TRIVAC B, Two-Stage Rotary Vane Vacuum Pumps TRIVAC D 4 B to D 65 B



The TRIVAC B is part of the well-proven TRIVAC concept.

The TRIVAC B pumps with their comprehensive range of accessories have proven themselves time and again as rugged pumps in many and varied applications.

The inner body is assembled from individual parts without sealing components. The parts are pinned in order to ensure easy disassembly and reassembly of the parts.

All pumps from the D 4 B to the D 25 B model are equipped either with single-phase or three-phase motors. D 40 - 65 B models are equipped with three-phase motors. Moreover, all pumps of the B series are available also without the motor.

In the TRIVAC B, the pump unit and the motor are linked by an elastic coupling.

The TRIVAC B range is a modular system which divides into three groups:

TRIVAC 4/8 Series
TRIVAC 16/25 Series
TRIVAC 40/65 Series

Advantages to the User

- All basic models (single-phase and three-phase motor) are certified in accordance with 94/9/EG (ATEX) (Category 3 inside)
- High water vapor tolerance
- Continuous operation even at 1000 mbar
- Built-in oil pump; pressure-lubricated sliding bearings
- All controls as well as the oil sight glass are located on the front face
- Either vertical or horizontal intake and exhaust ports
- Exchangeable inner body
- Anti-suckback valve controlled via the oil pressure
- Free of yellow metals
- Service-friendly
- Ideal as backing pump for medium and high vacuum applications, because of low oil backstreaming
- Highly leaktight (He-3-capable)

Typical Applications

See section "General, Applications and Accessories"

Supplied Equipment

Small flanges, centering and clamping rings. The intake flange contains a dirt trap.

A carrying handle is standard for all pumps up to the D 25 B. TRIVAC B pumps with single-phase motors are delivered with ON/OFF switch, mains cord and main plug, ready for immediate operation.

Standard TRIVAC B pumps come with a filling of oil N 62 (HE-200 in the US), others with special oil fillings can be specified.

All pumps are 100% subjected to a vacuum test before delivery!

Custom Models

- ATEX (Category 3 inside and 3 outside)
- Brake fluid
- Oils for refrigerating machines, e.g. ester oils for refrigerant circuits with R 134 a

Pressure burst resistant (for the new refrigerants propane and isobutane)

- He-3-tight (for cryostats)
- Special motors

TRIVAC D 16 B-DOT

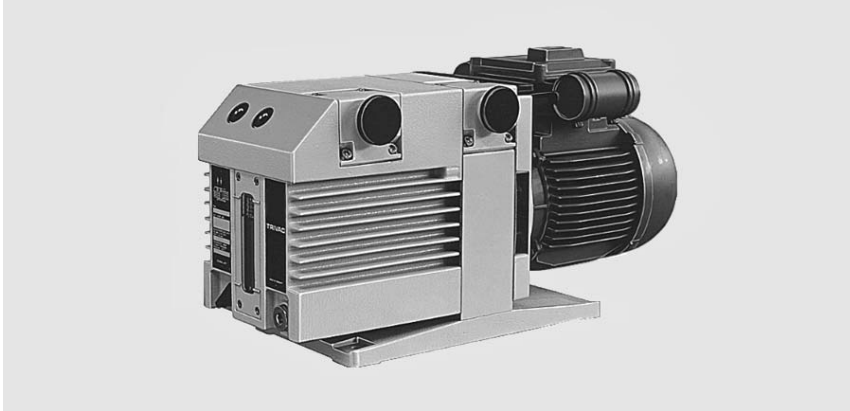

The TRIVAC B-DOT pumps operate with brake fluid (DOT 4) as the sealing and lubricating agent. Therefore these pumps are equipped with EPDM seals. EPDM is highly compatible with brake fluid.

As to the D 8 B-DOT, D 25 B-DOT and D 40 B-DOT please ask us for a quotation.

Advantages to the User

- Matching exhaust filters with EPDM gaskets (AF-DOT)
- Except for the seals and the fluid the TRIVAC B-DOT pumps are identical to the oil-sealed TRIVAC B pumps

Typical Applications

- For filling of brake fluid circuits in the automotive industry

Supplied Equipment

- The brake fluid is inside the pump when shipped

TRIVAC D 16 B-Ex, Explosion Protected and Pressure Burst Resistant

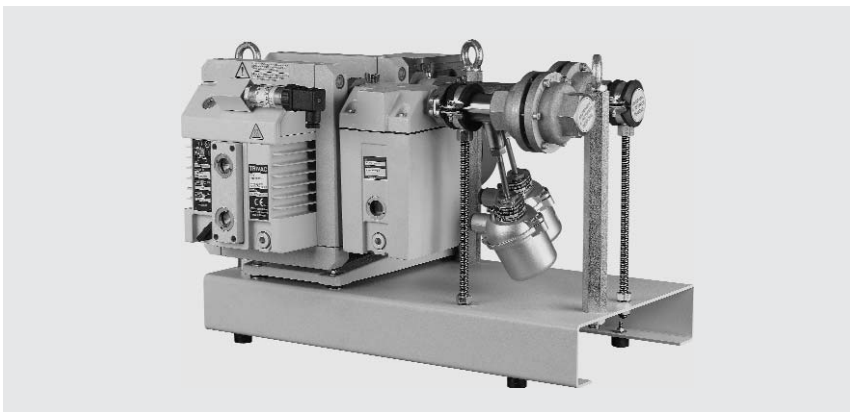

ATEX

Category 1 inside and 2 outside

Typical Applications

- Pumping of gases belonging to Group IIB3 and IIC ¹⁾ from Zone 0

Vacuum pumps TRIVAC D 16 B-Ex meet the requirements of the European Directive 94/9/EG (ATEX Directive). TRIVAC D 16 B-Ex pumps are classified inside as Category 1, outside as Category 2. Thus these pumps are suited for pumping explosive gases from Zone 0, the pump itself may be located in Zone 1.

The vacuum pumps TRIVAC D 16 B-Ex are qualified for gases of Explosion Groups IIC ¹⁾ and IIB3. The temperature class is T4. TRIVAC D 16 B-Ex pumps are explosion resistant and correspond to the state-of-the-art. They are equipped as standard with one each temperature sensor on the intake and delivery side.

Moreover, the pressure inside the pump is monitored. Flame arresters on the intake and delivery side protect the upstream and downstream system sections. Also provided as standard is an exhaust filter for every pump.

¹⁾ With the exception of acetylene and carbon bisulphide

TRIVAC D 4 B and D 8 B

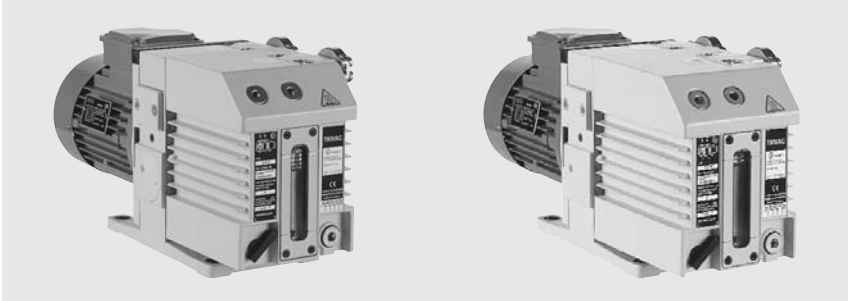

TRIVAC D 4 B (left) and TRIVAC D 8 B (right)

US pumps max. length
 D 4 B: 485 mm (19.1")
 D 8 B: 555 mm (21.9")

Type	DN	a	b	b ₁	b ₂	c	e	e ₁	h	h ₁	h ₂	h ₃	h ₄	l	l ₁	m	n	o	
D 4 B (Part No. 113 09)	16 KF	mm in.	75 2.95	162 6.38	147 5.79	132 5.23	100 3.94	-	170 6.69	265 10.43	215 8.46	200 7.87	230 9.06	259 10.20	-	455 17.91	198 7.80	99 3.90	108 4.25
D 4 B (Part No. 112 45)	16 KF	mm in.	75 2.95	162 6.38	147 5.79	132 5.23	100 3.94	102 4.02	265 10.43	215 8.46	200 7.87	230 9.06	234 9.21	437 17.21	-	198 7.80	99 3.90	108 4.25	
D 4 B (Part No. 112 46)	16 KF	mm in.	75 2.95	162 6.38	147 5.79	132 5.23	100 3.94	89 3.5	265 10.43	215 8.46	200 7.87	230 9.06	223 8.78	438 17.24	-	198 7.80	99 3.90	108 4.25	
D 4 B (Part No. 140 140)	16 KF	u. r.	u. r.	u. r.	u. r.	u. r.	u. r.	u. r.	u. r.	u. r.	u. r.	u. r.	u. r.	u. r.	u. r.	u. r.	u. r.	u. r.	u. r.
D 4 B (Part No. 140 081)	16 KF	mm in.	75 2.95	162 6.38	147 5.79	132 5.23	100 3.94	185 7.28	265 10.43	215 8.46	200 7.87	230 9.06	264 10.39	455 17.91	-	198 7.80	99 3.90	108 4.25	
D 8 B (Part No. 113 21)	16 KF	mm in.	100 3.94	162 6.38	147 5.79	132 5.23	100 3.94	-	170 6.69	265 10.43	215 8.46	200 7.87	230 9.06	259 10.20	-	480 18.90	198 7.80	99 3.90	108 4.25
D 8 B (Part No. 112 55)	16 KF	mm in.	100 3.94	162 6.38	147 5.79	132 5.23	100 3.94	102 4.02	265 10.43	215 8.46	200 7.87	230 9.06	234 9.21	462 18.19	-	198 7.80	99 3.90	108 4.25	
D 8 B (Part No. 112 56)	16 KF	mm in.	100 3.94	162 6.38	147 5.79	132 5.23	100 3.94	89 3.5	265 10.43	215 8.46	200 7.87	230 9.06	223 8.78	463 18.23	-	198 7.80	99 3.90	108 4.25	
D 8 B (Part No. 140 150)	16 KF	u. r.	u. r.	u. r.	u. r.	u. r.	u. r.	u. r.	u. r.	u. r.	u. r.	u. r.	u. r.	u. r.	u. r.	u. r.	u. r.	u. r.	u. r.
D 8 B (Part No. 140 082)	16 KF	mm in.	100 3.94	162 6.38	147 5.79	132 5.23	100 3.94	185 7.28	265 10.43	215 8.46	200 7.87	230 9.06	264 10.39	480 18.90	-	198 7.80	99 3.90	108 4.25	

u. r. = upon request

Dimensional drawing for the TRIVAC D 4 B and D 8 B

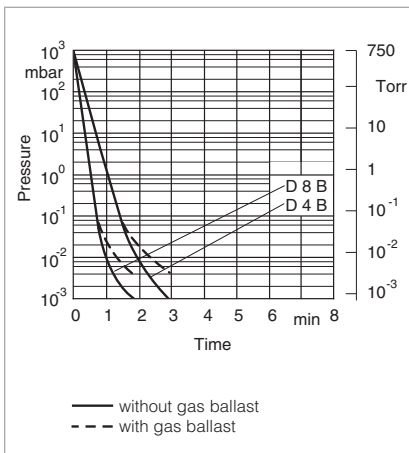

Pump-down characteristics of a 10 l vessel at 50 Hz

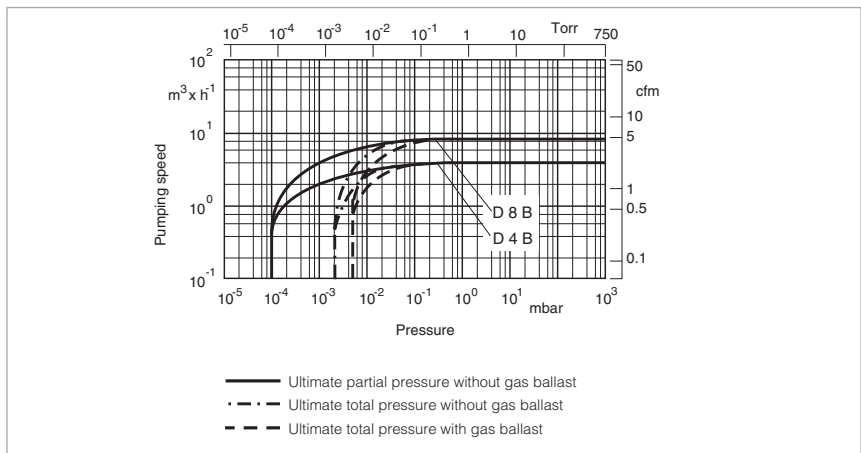

Pumping speed characteristics at 50 Hz (60 Hz curves at the end of the section)

Technical Data

TRIVAC D 4 B two-stage

TRIVAC D 8 B two-stage

		50 Hz	60 Hz	50 Hz	60 Hz
Nominal pumping speed ¹⁾	m ³ /h (cfm)	4.8 (2.8)	5.8 (3.4)	9.7 (5.7)	11.6 (6.9)
Pumping speed ¹⁾	m ³ /h (cfm)	4.2 (2.5)	5 (3)	8.5 (5)	10.2 (6)
Ultimate partial pressure without gas ballast ¹⁾	mbar (Torr)	10 ⁻⁴ (0.75 x 10 ⁻⁴)	10 ⁻⁴ (0.75 x 10 ⁻⁴)	10 ⁻⁴ (0.75 x 10 ⁻⁴)	10 ⁻⁴ (0.75 x 10 ⁻⁴)
Ultimate total pressure without gas ballast ¹⁾	mbar (Torr)	< 2 x 10 ⁻³ (< 1.5 x 10 ⁻³)	< 2 x 10 ⁻³ (< 1.5 x 10 ⁻³)	< 2 x 10 ⁻³ (< 1.5 x 10 ⁻³)	< 2 x 10 ⁻³ (< 1.5 x 10 ⁻³)
Ultimate total pressure with gas ballast ¹⁾	mbar (Torr)	< 5 x 10 ⁻³ (< 3.8 x 10 ⁻³)	< 5 x 10 ⁻³ (< 3.8 x 10 ⁻³)	< 5 x 10 ⁻³ (< 3.8 x 10 ⁻³)	< 5 x 10 ⁻³ (< 3.8 x 10 ⁻³)
Water vapor tolerance ¹⁾	mbar (Torr)	30 (22.5)	30 (22.5)	25 (18.8)	25 (18.8)
Water vapor capacity	g/h	93	93	157	157
Oil filling, min. / max.	l (qt)	0.3 / 0.8 (0.3 / 0.85)	0.3 / 0.8 (0.3 / 0.85)	0.3 / 0.9 (0.3 / 0.95)	0.3 / 0.9 (0.3 / 0.95)
Noise level ²⁾ to DIN 45 635, without / with gas ballast	dB(A)	50 / 52	50 / 52	50 / 52	50 / 52
Admissible ambient temperature	°C (°F)	+12 to +40 (+54 to +104)	+12 to +40 (+54 to +104)	+12 to +40 (+54 to +104)	+12 to +40 (+54 to +104)
Motor rating ²⁾	W (HP)	370 (0.50)	370 (0.50)	370 (0.50)	370 (0.50)
Nominal speed	rpm	1500	1800	1500	1800
Type of protection ³⁾	IP	54	54	54	54
Weight ²⁾	kg (lbs)	18.7 (41.2)	18.7 (41.2)	21.2 (46.7)	21.2 (46.7)
Connections, Intake and Exhaust	DN	16 KF	16 KF	16 KF	16 KF

¹⁾ To DIN 28 400 and following numbers

²⁾ Weight, motor rating and noise levels for the pumps with global version 230 V, 50 Hz AC motor only.

Any data that deviate from the above for pumps with other motors, and other motor-dependent data are given in section "Products", paragraph "Motor Dependent Data for the TRIVAC B, BCS and BCS-PFPE"

³⁾ Global versions only. North and South American versions are TEFC

Ordering Information

TRIVAC D 4 B two-stage

TRIVAC D 8 B two-stage

TRIVAC B without motor	Part No. 113 07	Part No. 113 17
with 1-phase motor 230 V, 50 Hz ¹⁾	Part No. 112 45	Part No. 112 55
with 3-phase motor 230/400 V, 50 Hz / 250/440 V, 60 Hz ¹⁾	Part No. 112 46	Part No. 112 56
230/400 V, 50 Hz, ATEX Category 3 inside and 3 outside inside: II (i) 3G IIC T4 (50 Hz) outside: II (o) 3G IIC T3 (50 Hz)	Part No. 140 140	Part No. 140 150
with dual voltage motor ²⁾ 100-120 V, 50/60 Hz and 200-240 V, 50/60 Hz	Part No. 140 081 ²⁾	Part No. 140 082 ²⁾
Mains cord for dual voltage motor ²⁾ 230 V earthed plug 230 V UK plug 230 V CH plug 230 V NEMA plug (200-240 V) 115 V NEMA plug (100-120 V)	Part No. 200 81 091 Part No. 200 81 097 Part No. 200 81 099 Part No. 200 81 141 Part No. 200 81 090	Part No. 200 81 091 Part No. 200 81 097 Part No. 200 81 099 Part No. 200 81 141 Part No. 200 81 090
Transition connector (250 V AC, 10 A, L+N+PE) only necessary in Switzerland for 1~ pumps	Part No. 800 001 274	Part No. 800 001 274
Accessories		
FS 2-4 dust filter	Part No. 186 05	Part No. 186 05
FA 2-4 fine vacuum adsorption trap	Part No. 187 05	Part No. 187 05
Adsorption trap with aluminium oxide	Part No. 854 14	Part No. 854 14
Activated aluminium oxide, 1.3 kg (2 l approx.)	Part No. 854 10	Part No. 854 10
TK 4-8 cold trap	Part No. 188 20	Part No. 188 20
AF 4-8 exhaust filter	Part No. 189 06	Part No. 189 06
AR 4-8 exhaust filter with lubricant return	Part No. 189 20	Part No. 189 20
AK 4-8 condensate trap	Part No. 188 06	Part No. 188 06
OF 4-25 mechanical oil filter	Part No. 101 91	Part No. 101 91
CF 4-25 chemical oil filter	Part No. 101 96	Part No. 101 96
Connector for gas ballast inlet M 16 x 1.5 – DN 16 KF	Part No. 168 40	Part No. 168 40
Oil drain tap M 16 x 1.5	Part No. 190 90	Part No. 190 90
Spare Parts		
Inner body	Part No. E 200 10 989	Part No. E 200 10 991
Major maintenance kit (without oil)	Part No. EK 110 002 622	Part No. EK 110 002 620
Minor maintenance kit (without oil)	Part No. EK 110 002 628	Part No. EK 110 002 627
Shaft sealing replacement kit	Part No. EK 110 002 631	Part No. EK 110 002 631
Small parts kit	Part No. EK 110 002 634	Part No. EK 110 002 634

¹⁾ Certification after 94/9/EG (ATEX), Category 3 inside. Inside: II (i) 3G IIC T4 (50 Hz), T3 (60 Hz)

²⁾ A mains cord needs to be ordered additionally

Only available for purchase in North and South America

Ordering Information

TRIVAC D 4 B two-stage

TRIVAC D 8 B two-stage

TRIVAC B with 1-phase motor 115 V, 60/50 Hz, NEMA plug 208-230 V, 60/50 Hz, NEMA plug	Part No. 912 45-1 Part No. 912 45-2	Part No. 912 55-1 Part No. 912 55-2
with 3-phase motor 208-230/460 V, 60 Hz / 200-220/380 V, 50 Hz	Part No. 912 46-2	Part No. 912 56-2

TRIVAC D 16 B and D 25 B

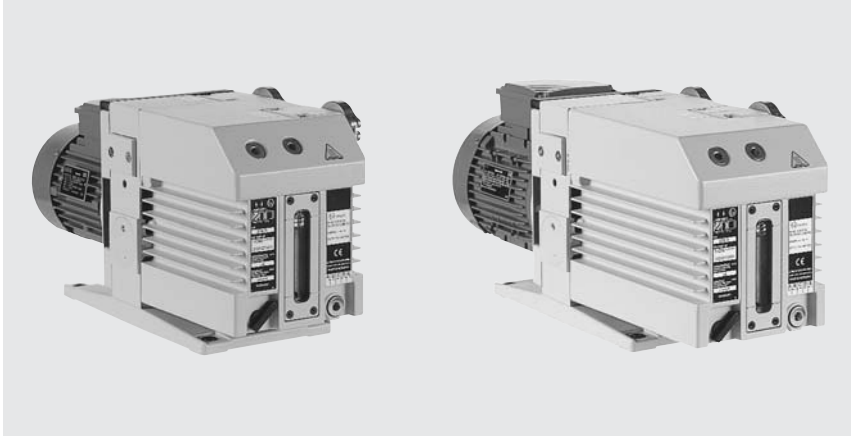

TRIVAC D 16 B (left) and TRIVAC D 25 B (right)

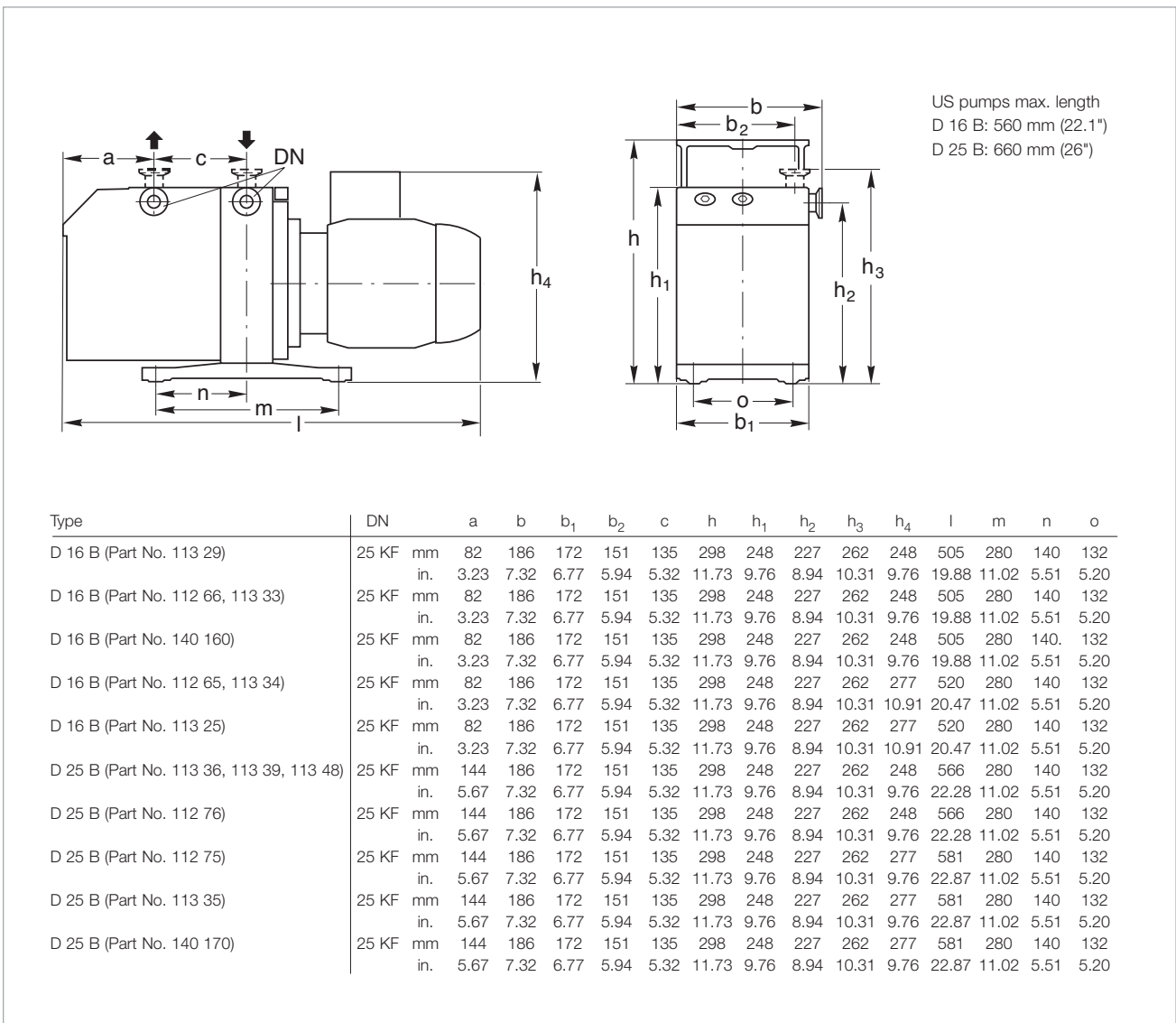

Dimensional drawing for the TRIVAC D 16 and D 25 B

Technical Data

TRIVAC D 16 B two-stage

TRIVAC D 25 B two-stage

		50 Hz	60 Hz	50 Hz	60 Hz
Nominal pumping speed ¹⁾	m ³ /h (cfm)	18.9 (11.1)	22.7 (13.4)	29.5 (17.4)	35.4 (20.9)
Pumping speed ¹⁾	m ³ /h (cfm)	16.5 (9.7)	19.8 (11.7)	25.7 (15.1)	30.8 (18.2)
Ultimate partial pressure without gas ballast ¹⁾	mbar (Torr)	10 ⁻⁴ (0.75 x 10 ⁻⁴)	10 ⁻⁴ (0.75 x 10 ⁻⁴)	10 ⁻⁴ (0.75 x 10 ⁻⁴)	10 ⁻⁴ (0.75 x 10 ⁻⁴)
Ultimate total pressure without gas ballast ¹⁾	mbar (Torr)	< 2 x 10 ⁻³ (1.5 x 10 ⁻³)	< 2 x 10 ⁻³ (1.5 x 10 ⁻³)	< 2 x 10 ⁻³ (1.5 x 10 ⁻³)	< 2 x 10 ⁻³ (1.5 x 10 ⁻³)
Ultimate total pressure with gas ballast ¹⁾	mbar (Torr)	< 5 x 10 ⁻³ (3.8 x 10 ⁻³)	< 5 x 10 ⁻³ (3.8 x 10 ⁻³)	< 5 x 10 ⁻³ (3.8 x 10 ⁻³)	< 5 x 10 ⁻³ (3.8 x 10 ⁻³)
Water vapor tolerance ¹⁾	mbar (Torr)	25 (18.8)	25 (18.8)	25 (18.8)	25 (18.8)
Water vapor capacity	g/h	305	305	476	476
Oil filling, min. / max.	l (qt)	0.5 / 1.0 (0.5 / 1.1)	0.5 / 1.0 (0.5 / 1.1)	0.6 / 1.4 (0.6 / 1.5)	0.6 / 1.4 (0.6 / 1.5)
Noise level ²⁾ to DIN 45 635, without / with gas ballast	dB(A)	52 / 62	52 / 62	52 / 62	52 / 62
Admissible ambient temperature	°C (°F)	+12 to +40 (+54 to +104)	+12 to +40 (+54 to +104)	+12 to +40 (+54 to +104)	+12 to +40 (+54 to +104)
Motor rating ²⁾	W (HP)	550 - 750 (0.75 - 1.0)	550 - 750 (0.75 - 1.0)	750 (1)	750 (1)
Nominal speed	rpm	1500	1800	1500	1800
Type of protection ³⁾	IP	54	54	54	54
Weight ²⁾	kg (lbs)	26 (57.3)	26 (57.3)	32 (70.6)	32 (70.6)
Connections, Intake and Exhaust	DN	25 KF	25 KF	25 KF	25 KF

¹⁾ To DIN 28 400 and following numbers

²⁾ Weight, motor rating and noise levels for the pumps with global version AC motor, 50 Hz, only.
Any data that deviate from the above for pumps with other motors, and other motor-dependent data are given in section "Products", paragraph "Motor Dependent Data for the TRIVAC B, BCS and BCS-PFPE"

³⁾ Global versions only. North and South American versions are TEFC

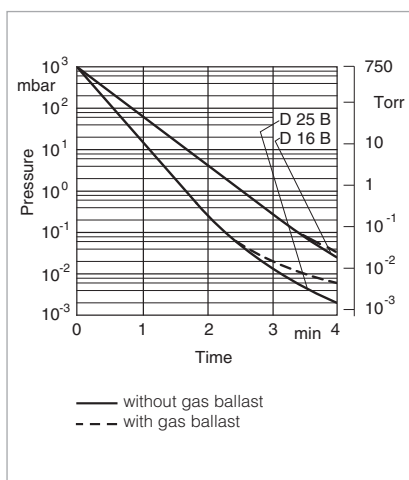

Pump-down characteristics of a 100 l vessel at 50 Hz

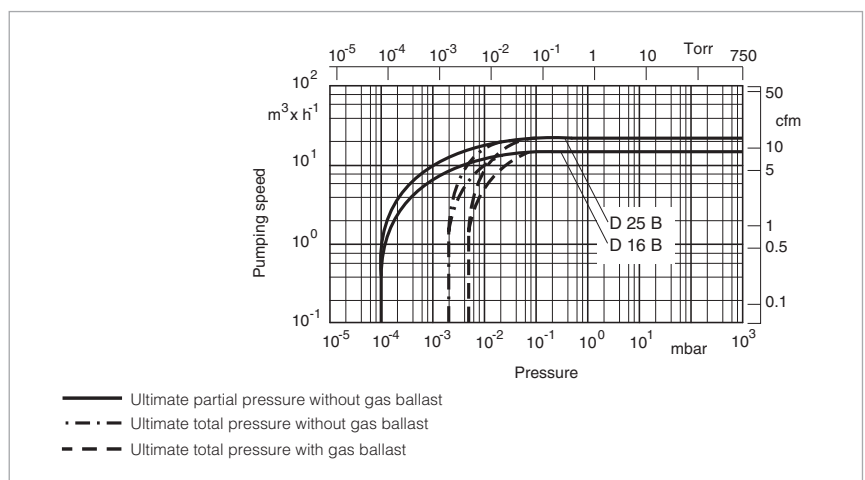

Pumping speed characteristics at 50 Hz (60 Hz curves at the end of the section)

Ordering Information

TRIVAC D 16 B two-stage

TRIVAC D 25 B two-stage

TRIVAC B without motor	Part No. 113 28	Part No. 113 38
with 1-phase motor 230 V, 50/60 Hz ¹⁾	Part No. 112 65	-
208 - 252 V, 50/60 Hz ¹⁾	Part No. 113 25 ²⁾	Part No. 113 35 ²⁾ / 112 75
100 V, 50 Hz / 110 V, 60 Hz	upon request	upon request
115 V, 60 Hz	-	Part No. 113 48
with 3-phase motor 230/400 V, 50 Hz / 250/440 V, 60 Hz ¹⁾	Part No. 112 66	Part No. 112 76
230/400 V, 50 Hz / 250/440 V, 60 Hz	Part No. 113 33 (RCF - E96N)	-
200/346 V, 50 Hz / 208/360 V, 60 Hz	Part No. 113 34 (RCF - E96N)	-
230/400 V, 50 Hz, ATEX Category 3 inside and 3 outside inside: II (i) 3G IIC T4 (50 Hz) outside: II (o) 3G IIC T3 (50 Hz)	Part No. 140 160	Part No. 140 170

Accessories

FS 8-16 dust filter	Part No. 186 10	Part No. 186 10
AS 8-16 dust separator	Part No. 186 11	Part No. 186 11
MF 8-16 molecular filter	Part No. 186 12	Part No. 186 12
FA 8-16 fine vacuum adsorption trap	Part No. 187 10	Part No. 187 10
Adsorption trap with aluminium oxide	Part No. 854 15	Part No. 854 15
Activated aluminium oxide, 1.3 kg (2 l approx.)	Part No. 854 10	Part No. 854 10
AF 16-25 exhaust filter	Part No. 189 11	Part No. 189 11
AR 16-25 exhaust filter with lubricant return	Part No. 189 21	Part No. 189 21
AK 16-25 condensate trap	Part No. 188 11	Part No. 188 11
OF 4-25 mechanical oil filter	Part No. 101 91	Part No. 101 91
CF 4-25 chemical oil filter	Part No. 101 96	Part No. 101 96
Connector for gas ballast inlet M 16 x 1.5 – DN 16 KF	Part No. 168 40	Part No. 168 40
Oil drain tap M 16 x 1.5	Part No. 190 90	Part No. 190 90

Spare Parts

Inner body	Part No. E 200 10 956	Part No. E 200 10 960
Major maintenance kit (without oil)	Part No. EK 110 002 618	Part No. EK 110 002 616
Minor maintenance kit (without oil)	Part No. EK 110 002 626	Part No. EK 110 002 625
Shaft sealing ring replacement kit	Part No. EK 110 002 630	Part No. EK 110 002 630
Small parts kit	Part No. EK 110 002 635	Part No. EK 110 002 635

¹⁾ Certification after 94/9/EG (ATEX), Category 3 inside. Inside: II (i) 3G IIC T4 (50 Hz), T3 (60 Hz)

²⁾ With cable EURO Schuko. Other cables for wide range motor upon request

Only available for purchase in North and South America

Ordering Information

TRIVAC D 16 B two-stage

TRIVAC D 25 B two-stage

TRIVAC B with 1-phase motor 115 V, 60/50 Hz, NEMA plug 208-230 V, 60/50 Hz, NEMA plug	Part No. 912 65-1 Part No. 912 65-2	Part No. 912 75 V 001 Part No. 912 75-2
with 3-phase motor 208-230/460 V, 60 Hz / 200-220/380 V, 50 Hz	Part No. 912 66-2	Part No. 912 76-2

TRIVAC D 40 B and D 65 B

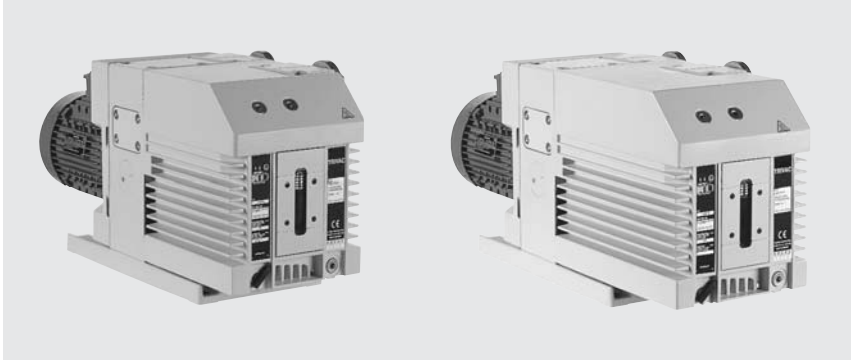

TRIVAC D 40 B (left) and TRIVAC D 65 B (right)

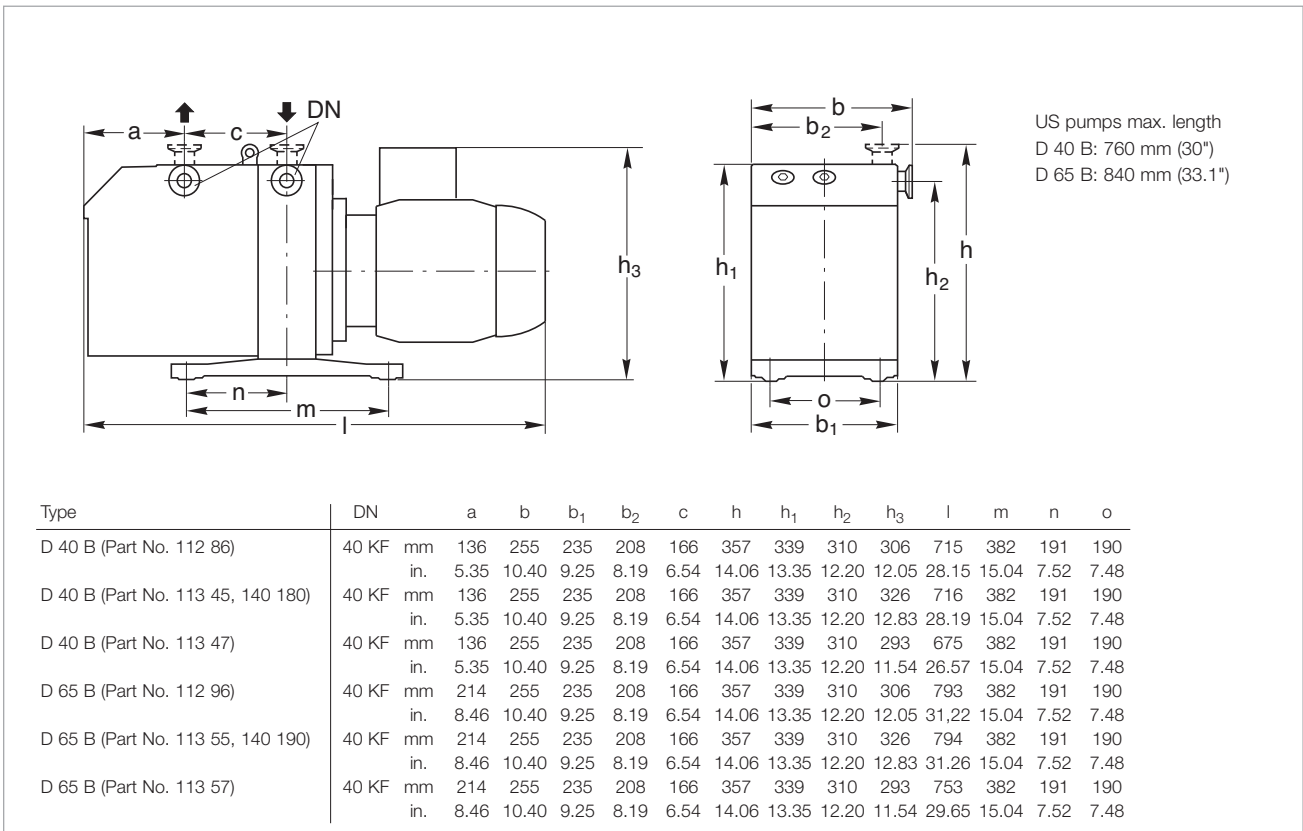

Dimensional drawing for the TRIVAC D 40 and D 65 B

Technical Data

TRIVAC D 40 B two-stage

TRIVAC D 65 B two-stage

		50 Hz	60 Hz	50 Hz	60 Hz
Nominal pumping speed ¹⁾	m ³ /h (cfm)	46 (27)	55 (32.5)	75 (44)	90 (53)
Pumping speed ¹⁾	m ³ /h (cfm)	40 (24)	48 (28)	65 (38)	78 (46)
Ultimate partial pressure without gas ballast ¹⁾	mbar (Torr)	10 ⁻⁴ (0.75 x 10 ⁻⁴)	10 ⁻⁴ (0.75 x 10 ⁻⁴)	10 ⁻⁴ (0.75 x 10 ⁻⁴)	10 ⁻⁴ (0.75 x 10 ⁻⁴)
Ultimate total pressure without gas ballast ¹⁾	mbar (Torr)	< 2 x 10 ⁻³ (< 1.5 x 10 ⁻³)	< 2 x 10 ⁻³ (< 1.5 x 10 ⁻³)	< 2 x 10 ⁻³ (< 1.5 x 10 ⁻³)	< 2 x 10 ⁻³ (< 1.5 x 10 ⁻³)
Ultimate total pressure with gas ballast ¹⁾	mbar (Torr)	< 5 x 10 ⁻³ (< 3.8 x 10 ⁻³)	< 5 x 10 ⁻³ (< 3.8 x 10 ⁻³)	< 5 x 10 ⁻³ (< 3.8 x 10 ⁻³)	< 5 x 10 ⁻³ (< 3.8 x 10 ⁻³)
Water vapor tolerance ¹⁾	mbar (Torr)	40 (30)	40 (30)	40 (30)	40 (30)
Water vapor capacity	g/h	1184	1184	1925	1925
Oil filling, min. / max.	l (qt)	1.7 / 2.6 (1.8 / 2.7)	1.7 / 2.6 (1.8 / 2.7)	2.0 / 3.3 (2.1 / 3.5)	2.0 / 3.3 (2.1 / 3.5)
Noise level ²⁾ to DIN 45 635, without / with gas ballast	dB(A)	57 / 59	57 / 59	57 / 59	57 / 59
Admissible ambient temperature	°C (°F)	+12 to +40 (+54 to +104)	+12 to +40 (+54 to +104)	+12 to +40 (+54 to +104)	+12 to +40 (+54 to +104)
Motor rating ²⁾	W (HP)	2200 (3.0)	2200 (3.0)	2200 (3.0)	2200 (3.0)
Nominal speed	rpm	1420	1710	1420	1710
Type of protection ³⁾	IP	54	54	54	54
Weight ²⁾	kg (lbs)	68 (150)	68 (150)	80 (177)	80 (177)
Connections, Intake and Exhaust	DN	40 KF	40 KF	40 KF	40 KF

1) To DIN 28 400 and following numbers

2) Weight, motor rating and noise levels for the pumps with global version 3-phase motor, 50 Hz, only.

Any data that deviate from the above for pumps with other motors, and other motor-dependent data are given in section "Products", paragraph "Motor Dependent Data for the TRIVAC B, BCS and BCS-PFPE"

3) Global versions only. North and South American versions are TEFC

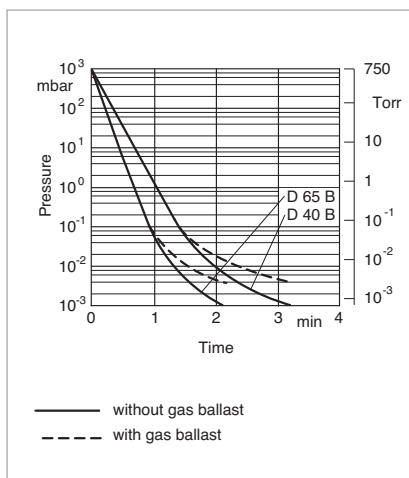

Pump-down characteristics of a 100 l vessel at 50 Hz

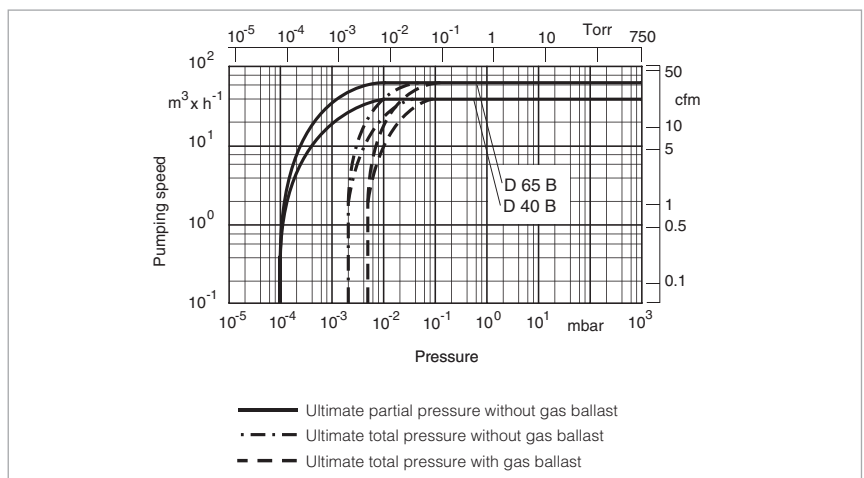

Pumping speed characteristics at 50 Hz (60 Hz curves at the end of the section)

Ordering Information**TRIVAC D 40 B****TRIVAC D 65 B****two-stage****two-stage**

TRIVAC B		
without motor	Part No. 113 46	Part No. 113 56
with 3-phase motor		
230/400 V, 50 Hz / 250/440 V, 60 Hz ¹⁾	Part No. 112 86	Part No. 112 96
200/346 V, 50 Hz / 208/360 V, 60 Hz	Part No. 113 47	Part No. 113 57
200/346 V, 50 Hz / 208/360 V, 60 Hz ATEX Category 3 inside and 3 outside inside: II (i) 3G IIC T4 (50 Hz) outside: II (o) 3G IIC T3 (50 Hz)	Part No. 140 180	Part No. 140 190
Accessories		
Roots pump adaptor	Part No. 168 30	Part No. 168 30
FS 30-60 dust filter	Part No. 186 15	Part No. 186 15
AS 30-60 dust separator	Part No. 186 16	Part No. 186 16
MF 30-60 molecular filter	Part No. 186 17	Part No. 186 17
FA 30-60 fine vacuum adsorption trap	Part No. 187 15	Part No. 187 15
Adsorption trap with aluminium oxide	Part No. 854 16	Part No. 854 16
Activated aluminium oxide, 1.3 kg (2 l approx.)	Part No. 854 10	Part No. 854 10
AF 40-65 exhaust filter	Part No. 189 16	Part No. 189 16
AR 40-65 exhaust filter with lubricant return	Part No. 189 22	Part No. 189 22
AK 40-65 condensate trap	Part No. 188 16	Part No. 188 16
OF 40-65 mechanical oil filter	Part No. 101 92	Part No. 101 92
CF 40-65 chemical oil filter	Part No. 101 97	Part No. 101 97
Connector for gas ballast inlet M 16 x 1.5 – DN 16 KF	Part No. 168 40	Part No. 168 40
Oil drain tap M 16 x 1.5	Part No. 190 90	Part No. 190 90
Spare Parts		
Inner body	Part No. E 200 10 933	Part No. E 200 10 944
Major maintenance kit (without oil)	Part No. EK 110 002 613	Part No. EK 110 002 612
Minor maintenance kit (without oil)	Part No. EK 110 002 624	Part No. EK 110 002 624
Shaft sealing ring replacement kit	Part No. EK 110 002 629	Part No. EK 110 002 629
Small parts kit	Part No. EK 110 002 636	Part No. EK 110 002 636

¹⁾ Certification after 94/9/EG (ATEX), Category 3 inside. Inside: II (i) 3G IIC T4 (50 Hz), T3 (60 Hz)

Only available for purchase in North and South America

Ordering Information

TRIVAC D 40 B two-stage

TRIVAC D 65 B two-stage

TRIVAC B
with 3-phase motor
208-230/460 V, 60 Hz /
200-220/380 V, 50 Hz

Part No. 912 86-2

Part No. 912 96-2

TRIVAC D 16 B-DOT

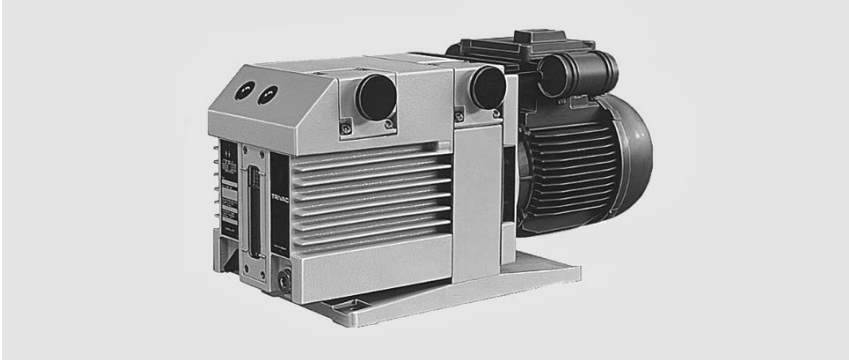

TRIVAC D 16 B-DOT

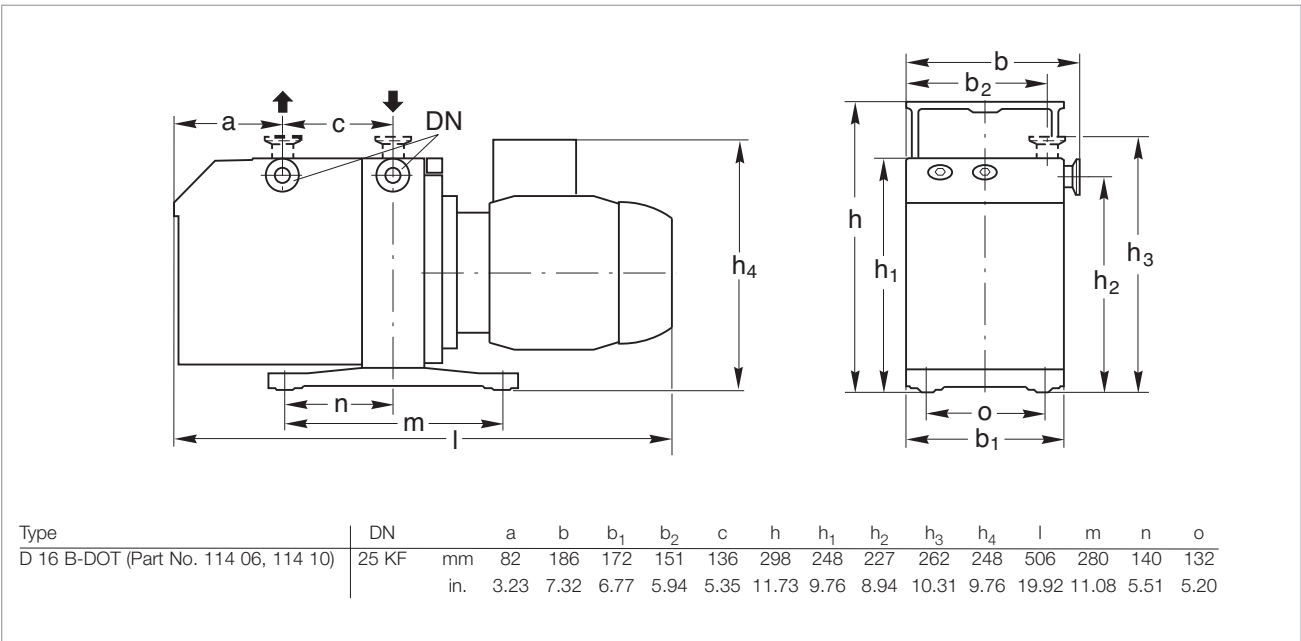

Dimensional drawing for the TRIVAC D 16 B-DOT

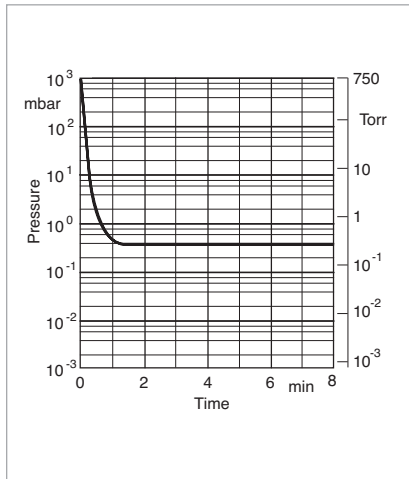

Pump-down characteristics of a 10 l vessel at 50 Hz

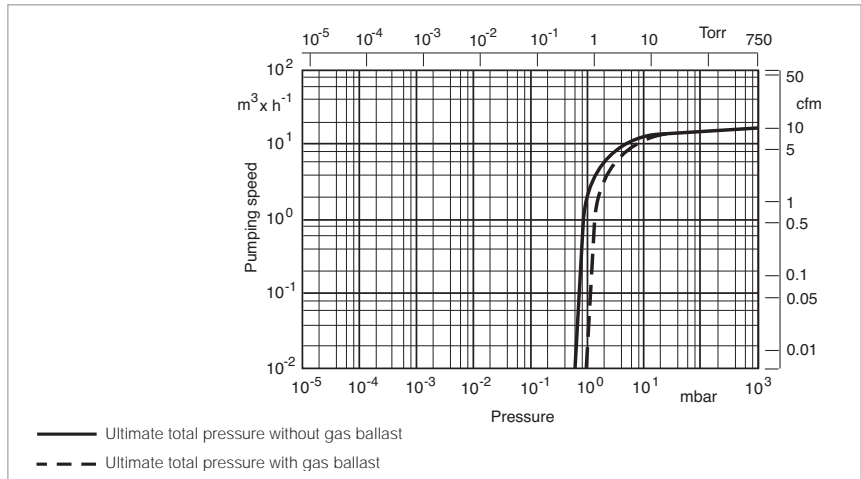

Pumping speed characteristics at 50 Hz (60 Hz curves at the end of the section)

Technical Data

TRIVAC D 16 B-DOT

		50 Hz	60 Hz
Nominal pumping speed ¹⁾	m ³ /h (cfm)	18.9 (11.1)	22.7 (13.4)
Pumping speed ¹⁾	m ³ /h (cfm)	16.5 (9.7)	19.8 (11.7)
Ultimate total pressure without gas ballast ¹⁾	mbar (Torr)	< 6 x 10 ⁻¹ (< 4.5 x 10 ⁻¹)	< 6 x 10 ⁻¹ (< 4.5 x 10 ⁻¹)
Ultimate total pressure with gas ballast ¹⁾	mbar (Torr)	< 9 x 10 ⁻¹ (< 6.75 x 10 ⁻¹)	< 9 x 10 ⁻¹ (< 6.75 x 10 ⁻¹)
Water vapor tolerance ¹⁾	mbar (Torr)	25 (18.75)	25 (18.75)
Water vapor capacity	g/h	259	259
Brake fluid filling, min. / max.	l (qt)	0.45 / 1.0 (0.5 / 1.1)	0.45 / 1.0 (0.5 / 1.1)
Noise level to DIN 45 635, without / with gas ballast	dB(A)	52 / 52	52 / 52
Admissible ambient temperature	°C (°F)	+12 to +40 (+54 to +104)	+12 to +40 (+54 to +104)
Motor rating	W (HP)	550 (0.75)	550 (0.75)
Nominal speed	rpm	1500	1800
Type of protection ²⁾	IP	54	54
Weight	kg (lbs)	26 (57.3)	26 (57.3)
Connections, Intake and Exhaust	DN	25 KF	25 KF

Ordering Information

TRIVAC D 16 B-DOT

	Global Version	North and South America Version
TRIVAC B-DOT		
with 3-phase motor		
230/400 V, 50 Hz; 250/440 V, 60 Hz	Part No. 114 06	
230/400 V, 50 Hz; 250/440 V, 60 Hz	Part No. 114 10 (with float switch)	-
with 1-phase motor 115 V, 60 Hz	-	Part No. 914 62
with 3-phase motor 208-230/460 V, 60 Hz 208-220/380 V, 50 Hz	-	Part No. 914 63
AF 16-25 DOT exhaust filter	Part No. 124 16	Part No. 124 16
AK 16 DOT condensate trap	Part No. 110 78	Part No. 110 78
Seal kit	Part No. 200 39 059	Part No. 200 39 059

¹⁾ To DIN 28 400 and following numbers

²⁾ Global versions only. North and South American versions are TEFC

As to the D 8 B-DOT, D 25 B-DOT and D 40 B-DOT please ask us for a quotation.

TRIVAC D 16 B-Ex (Explosion Protected and Pressure Burst Resistant)

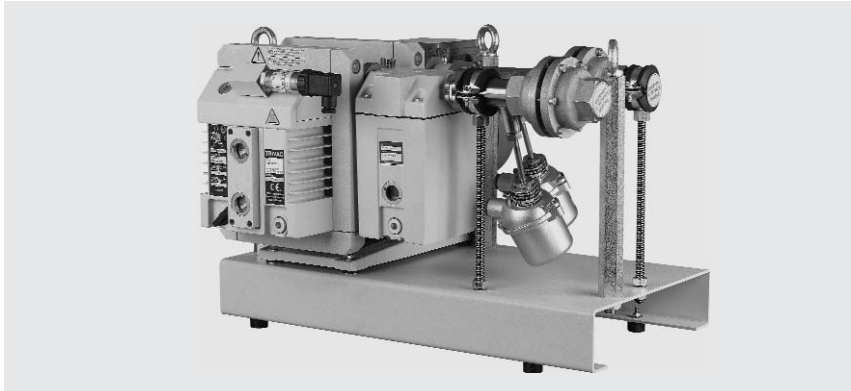

ATEX

Category 1 inside and 2 outside

TRIVAC D 16 B-Ex

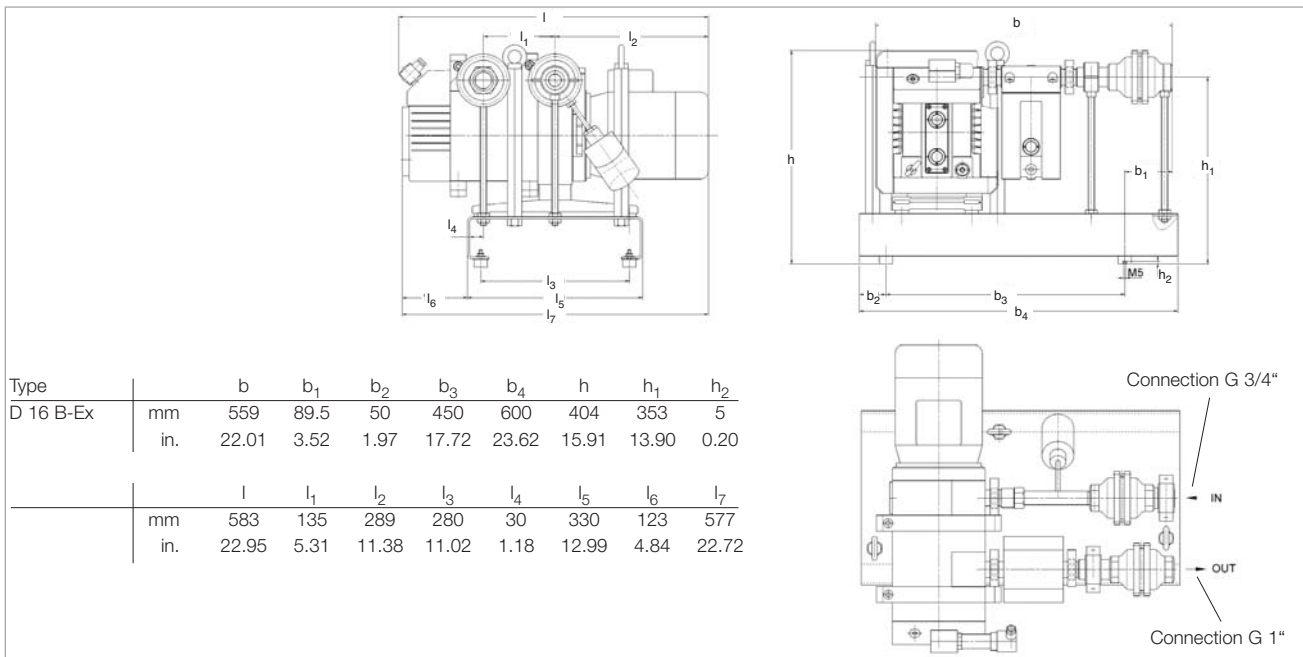

Dimensional drawing for the TRIVAC 16 B-Ex (explosion protected and pressure burst resistant)

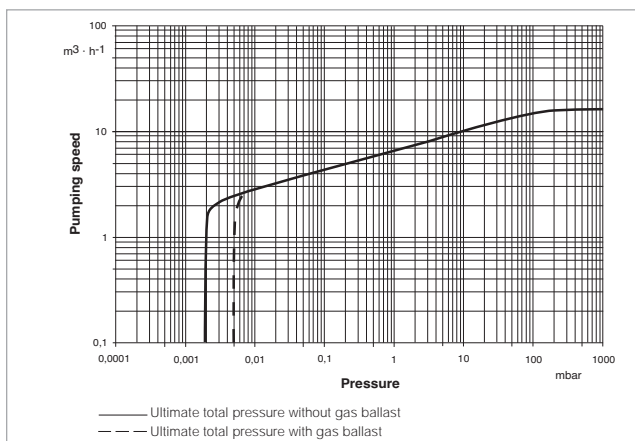

Pumping speed characteristics of TRIVAC D 16 B-Ex [IIB3 T4]
(Part No. 140 091)

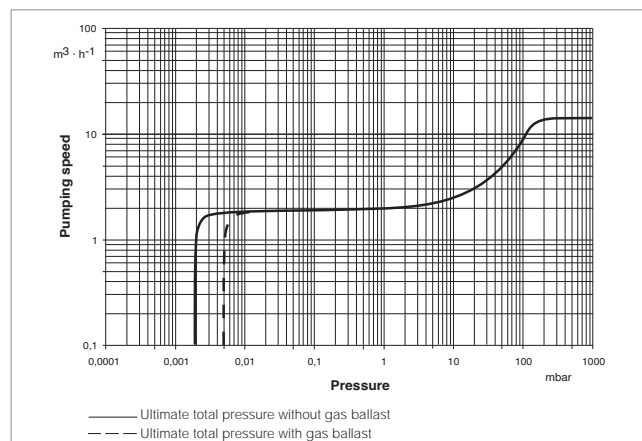

Pumping speed characteristics of TRIVAC D 16 B-Ex [IIC T4]
(Part No. 140 092)

Technical Data

TRIVAC D 16 B-Ex (Explosion Protected and Pressure Burst Resistant) Two-Stage

Nominal pumping speed ¹⁾	m ³ /h (cfm)	18.9 (11.1)
Pumping speed (for Part No. 140 091 / 140 092) ¹⁾	m ³ /h (cfm)	16 / 15 (9.4/8.8)
Ultimate total pressure without gas ballast ¹⁾	mbar (Torr)	1 x 10 ⁻⁴ (< 0.75 x 10 ⁻³)
Ultimate total pressure with gas ballast ¹⁾	mbar (Torr)	< 5 x 10 ⁻³ (< 3.8 x 10 ⁻³)
Water vapor tolerance ¹⁾	mbar (Torr)	25 (18.75)
Water vapor capacity	gm/h	305
Oil filling, min. / max.	l (qt)	0.55 / 1.3 (0.58 / 1.4)
Motor		3~, 230 V / 400 V, 50 Hz, EEx e II T4
Type of protection	IP	54
Maximum gas inlet temperature	°C (°F)	60 (260)
Highest permissible pressure in the oil box	mbar (Torr)	500 (375)
Ambient temperature (t _a)	°C (°F)	+12 to +40 (+46 - +104)
Maximum surface temperature	°C (°F)	135 (275)
Max. Inlet pressure	mbar (Torr)	Atmospheric pressure
Weight (complete systems)	kg (lbs)	72 (159)
Materials (materials in contact with the gas)		Steel, hardened steel, spring steel, stainless steel, zinc, aluminum and aluminum alloys, grey cast iron 25, FKM, felt, glass, silicone, polyamide
Connections		
Intake side	Inside thread	G 3/4"
Pressure side	Inside thread	G 1"

Ordering Information

TRIVAC D 16 B-Ex (Explosion Protected and Pressure Burst Resistant) Two-Stage

TRIVAC D 16 B-Ex IIB3 T4 in accordance with 94/9/EC [ II inside: 1G IIB3 T4 outside: 2G IIB T4 (12 °C < t _a < 40 °C) X EC Type Examination Certificate: IBExU03ATEX1017 X]	Part No. 140 091
TRIVAC D 16 B-Ex IIC T4 ²⁾ in accordance with 94/9/EC [ II inside: 1G IIC (no C ₂ H ₂ , CS ₂) T4 outside: 2G IIC T4 (12 °C < t _a < 40 °C) X EC Type Examination Certificate: IBExU03ATEX1016 X]	Part No. 140 092 ²⁾

¹⁾ To DIN 28 400 and following numbers

²⁾ with the exception of acetylene and carbon bisulphide

For all enquiries and orders relating to category 1 and 2 ATEX products please exclusively use our ATEX questionnaire. You can find this questionnaire at the end of the full-line catalog together with the fax forms or in the Internet under "www.oerlikon.com/leyboldvacuum" under Download Documents in the area Documentation.

TRIVAC BCS, Two-Stage Rotary Vane Vacuum Pumps

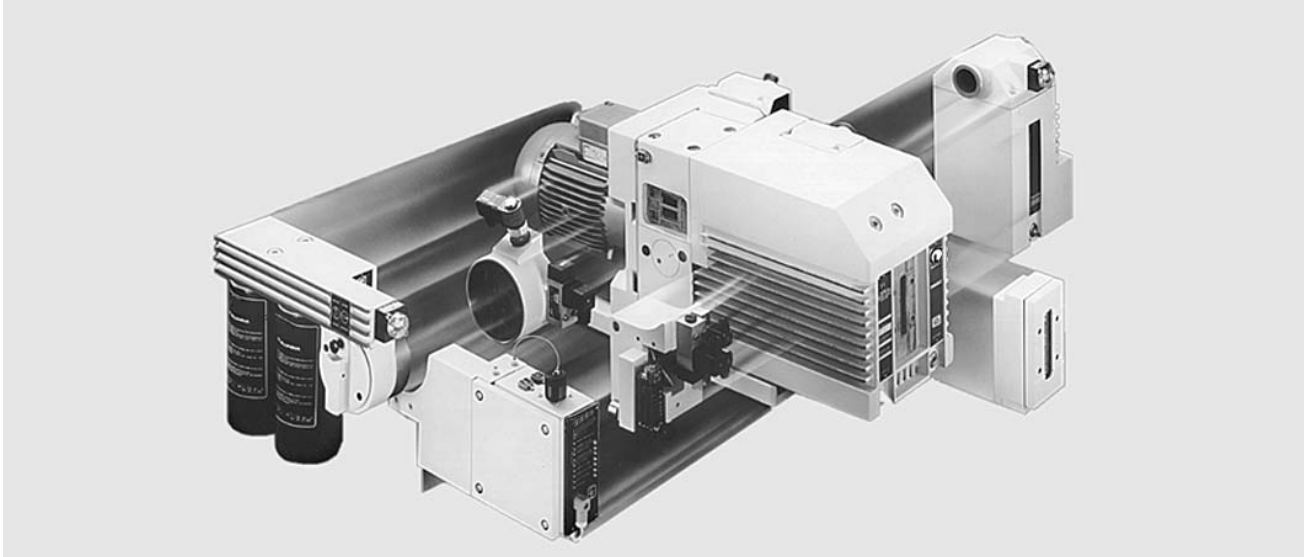

TRIVAC SYSTEM

The TRIVAC BCS pumps are oil-sealed vacuum pumps operating according to the rotary vane principle. Oil which is injected into the pump chamber is used for sealing, lubrication and cooling purposes.

The pump body is assembled from individual parts without sealing components. The parts are pinned in order to ensure easy disassembly and reassembly of the parts.

The TRIVAC BCS are available with a three-phase motor (The North and South American TRIVAC D 16/25 BCS are also available with single-phase motors). The motor is connected to the pumping section via an elastic coupling.

In addition, the TRIVAC BCS is ready for system integration (adaptable to different applications).

Advantages to the User

- Compact design
- Low noise operation with hardly any vibrations
- Built-in oil pump
- Continuous operation even at 1000 mbar (750 Torr)
- Pressure-lubricated sliding bearings

- Anti-suckback valve controlled via the oil pressure, no backstreaming of oil, independent of the operating mode, with or without gas ballast
- Low backstreaming of oil within the pump
- High pumping speed down to ultimate pressure
- Either vertical or horizontal intake and exhaust ports
- All controls as well as the oil sight glass are located on the face side
- Low power consumption
- Produces very little heat
- Exchangeable inner section
- Main flow oil filters may be fitted
- Very long service life
- Modular system
- Service-friendly
- Built-in temperature switch for temperature monitoring
- Corrosion protected – the use of yellow metals has been avoided; only grey cast iron, surface treated aluminium, steel and stainless steel is used
- Double shaft seal

Typical Applications

- In all areas of vacuum engineering
- Pumping of corrosive or aggressive media
- Production of semiconductors and in the area of chemistry
- Research and production
- Generation of rough and medium vacuum
- Backing pump in pump sets, i.e. in connection with Roots, diffusion, turbo or cryopumps

Supplied Equipment

- Small flanges
- Centering, sealing and clamping rings
- The intake port includes a dirt trap

BCS pumps are supplied with a filling of standard oil N 62, (HE-200 oil in the US).

All pumps are subjected to a vacuum test before delivery!

TRIVAC SYSTEM

The TRIVAC BCS and its accessories

- CFS, chemical filter with safety isolation valve
- ARS, exhaust filter with lubricant return
- IGS, inert gas system
- LSS, limit switch system and make up the TRIVAC SYSTEM.

TRIVAC BCS-PFPE

In many applications the use of synthetic lubricants like perfluoropolyether (PFPE) offers superior characteristics compared to mineral oils.

Advantages of perfluoropolyether (PFPE) NC 1/14 and HE-1600:

- Practically inert against all chemical and oxidizing influences.
- No polymerization under the influence of high energy radiation.
- In part significantly increased oil change intervals.
- Thermally highly stable. Thermal decomposition will only occur at temperatures over 290 °C (554 °F).

BCS-PFPE pumps have been especially prepared for operation with PFPE and are supplied **without** the oil filling in global versions, but **with** oil in versions for North and South America. We recommend using our operating fluid PFPE NC 1/14 or HE-1600 and always to install a chemical oil filter CF or CFS.

TRIVAC D 16 BCS to D 65 BCS

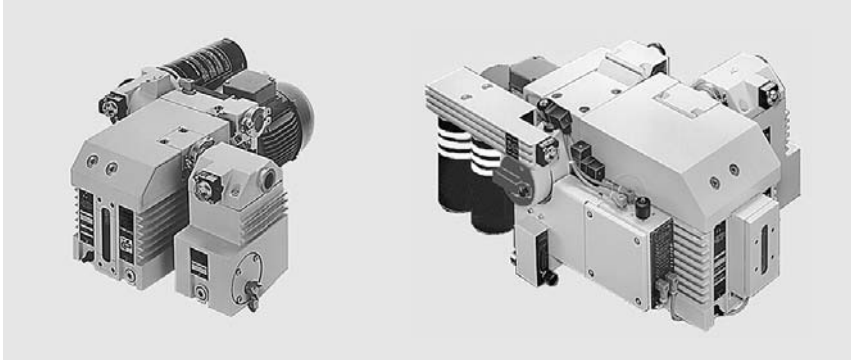

TRIVAC D 25 BCS with ARS and CFS (left)
and TRIVAC D 65 BCS with CFS, ARS, IGS, LSS, EIS – TRIVAC SYSTEM (right)

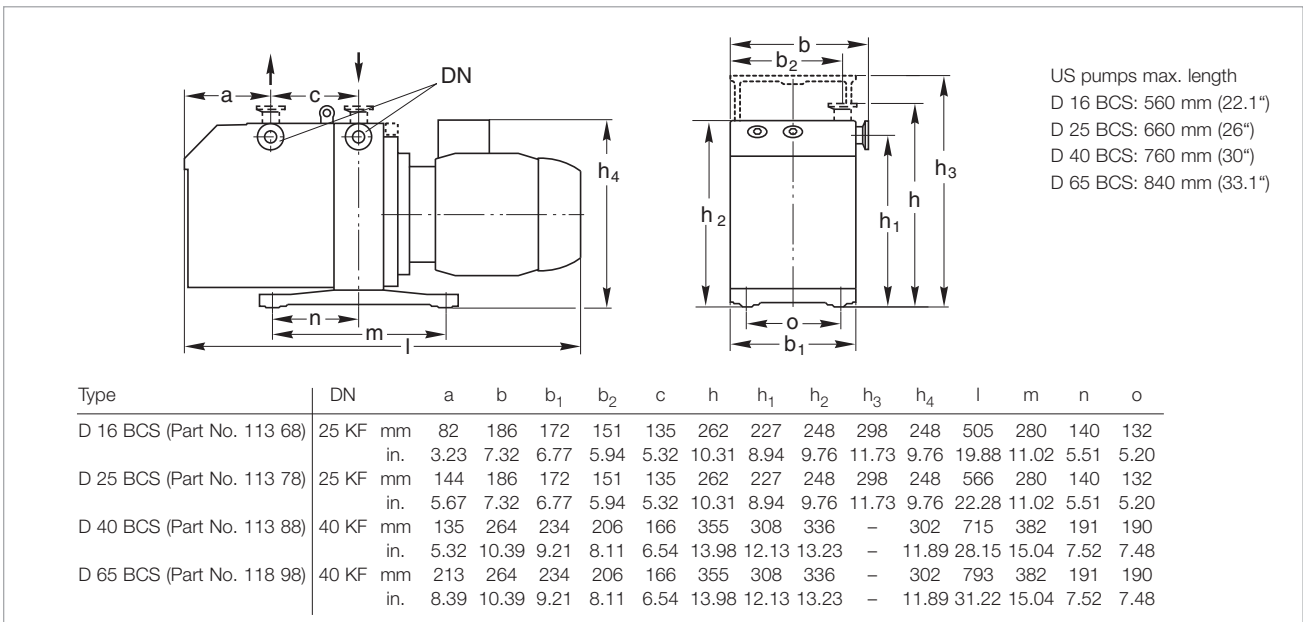

US pumps max. length
 D 16 BCS: 560 mm (22.1")
 D 25 BCS: 660 mm (26")
 D 40 BCS: 760 mm (30")
 D 65 BCS: 840 mm (33.1")

Dimensional drawing for the TRIVAC D 16 to D 65 BCS

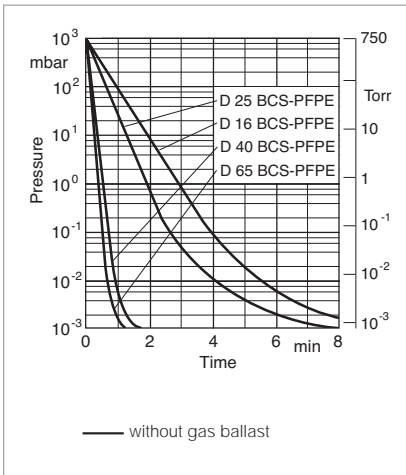

Pump-down characteristics of a 100 l vessel at 50 Hz

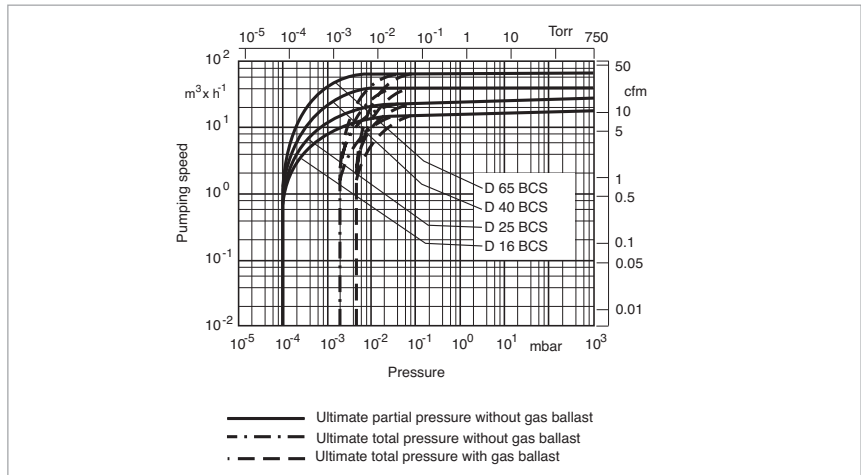

Pumping speed characteristics at 50 Hz (60 Hz curves at the end of the section)

Technical Data, 50 Hz

TRIVAC

		D 16 BCS	D 25 BCS	D 40 BCS	D 65 BCS
		two-stage	two-stage	two-stage	two-stage
Nominal pumping speed 50/60 Hz ¹⁾	m ³ /h (cfm)	18.9 (11.1) / 22.7 (13.4)	29.5 (17.4) / 35.4 (20.9)	46 (27) / 55 (32.5)	75 (44) / 90 (53)
Pumping speed 50/60 Hz ¹⁾	m ³ /h (cfm)	16.5 (9.7) / 19.8 (11.7)	25.7 (15.1) / 30.8 (18.2)	40 (24) / 48 (28)	65 (38) / 78 (46)
Ultimate partial pressure without gas ballast ¹⁾	mbar (Torr)	10 ⁻⁴ (0.75 x 10 ⁻⁴)	10 ⁻⁴ (0.75 x 10 ⁻⁴)	10 ⁻⁴ (0.75 x 10 ⁻⁴)	10 ⁻⁴ (0.75 x 10 ⁻⁴)
Ultimate total pressure without gas ballast ¹⁾	mbar (Torr)	< 2.5 x 10 ⁻³ (< 1.9 x 10 ⁻³)	< 2.5 x 10 ⁻³ (< 1.9 x 10 ⁻³)	< 2 x 10 ⁻³ (< 1.5 x 10 ⁻³)	< 2 x 10 ⁻³ (< 1.5 x 10 ⁻³)
Ultimate total pressure with gas ballast ¹⁾	mbar (Torr)	< 5 x 10 ⁻³ (< 3.8 x 10 ⁻³)	< 5 x 10 ⁻³ (< 3.8 x 10 ⁻³)	< 5 x 10 ⁻³ (< 3.8 x 10 ⁻³)	< 5 x 10 ⁻³ (< 3.8 x 10 ⁻³)
Water vapor tolerance ¹⁾	mbar (Torr)	25 (18.8)	25 (18.8)	40 (30)	40 (30)
Water vapor capacity	g/h	305	476	1184	1925
Oil filling, min. / max.	l (qt)	0.45 / 1.0 (0.5/1.1)	0.6 / 1.4 (0.6/1.5)	1.7 / 2.6 (1.8/2.7)	2.0 / 3.3 (2.1/3.5)
Noise level ²⁾ to DIN 45 635, without / with gas ballast	dB(A)	52 / 54	52 / 54	57 / 59	57 / 59
Admissible ambient temperature	°C (°F)	+12 to +40 (+54 to +104)	+12 to +40 (+54 to +104)	+12 to +40 (+54 to +104)	+12 to +40 (+54 to +104)
Motor rating ²⁾	W (HP)	550 (0.75)	750 (1)	2200 (3)	2200 (3)
Nominal speed 50/60 Hz	rpm	1500 / 1800	1500 / 1800	1500 / 1800	1500 / 1800
Type of protection ³⁾	IP	55	55	55	55
Weight ²⁾	kg (lbs)	26 (57.3)	32 (70.6)	68 (150)	80 (176.4)
Connections, Intake and Exhaust	DN	25 KF	25 KF	40 KF	40 KF

¹⁾ To DIN 28 400 and following numbers

²⁾ Weight, motor rating and noise levels for the pumps with global version 3-phase motor, 50 Hz, only.

Any data that deviate from the above for pumps with other motors, and other motor-dependent data are given in section "Products", paragraph "Motor Dependent Data for the TRIVAC B, BCS and BCS-PFPE"

³⁾ Global versions only. North and South American versions are TEFC

Ordering Information

TRIVAC

D 16 BCS
two-stage

D 25 BCS
two-stage

D 40 BCS
two-stage

D 65 BCS
two-stage

TRIVAC BCS with 3-phase motor 230/400 V, 50 Hz / 250/440 V, 60 Hz	Part No. 113 68	Part No. 113 78	Part No. 113 88	Part No. 113 98
Accessories				
Roots pump adaptor	-	-	Part No. 168 30	Part No. 168 30
Exhaust filter with lubricant return ARS 16-25 ARS 40-65	Part No. 189 56 -	Part No. 189 56 -	- Part No. 189 57	- Part No. 189 57
Condensate separator AK 16-25 AK 40-65	Part No. 188 11 -	Part No. 188 11 -	- Part No. 188 16	- Part No. 188 16
Chemical filter with safety blocking valve CFS 16-25 CFS 40-65	Part No. 101 76 -	Part No. 101 76 -	- Part No. 101 77	- Part No. 101 77
Inert gas system IGS 16-25 IGS 40-65	Part No. 161 76 -	Part No. 161 76 -	- Part No. 161 77	- Part No. 161 77
Limit switch system LSS 16-25 LSS 40-65	Part No. 161 06 -	Part No. 161 06 -	- Part No. 161 07	- Part No. 161 07
Spare Parts				
Inner body	Part No. 200 39 762	Part No. 200 39 764	Part No. 200 39 758	Part No. 200 39 760
Major maintenance kit, N 62 (without oil)	Part No. EK 110 002 646	Part No. EK 110 002 647	Part No. EK 110 002 641	Part No. EK 110 002 642
Minor maintenance kit, N 62 (without oil)	Part No. EK 110 002 649	Part No. EK 110 002 648	-	-
Shaft sealing replacement kit	Part No. EK 110 002 650	Kat.-Nr EK 110 002 650	Part No. EK 110 002 643	Part No. EK 110 002 643
Small parts kit	-	-	Part No. EK 110 002 651	Part No. EK 110 002 651

Only available for purchase in North and South America

Ordering Information

	TRIVAC			
	D 16 BCS	D 25 BCS	D 40 BCS	D 65 BCS
	two-stage	two-stage	two-stage	two-stage
TRIVAC BCS with 3-phase motor 208-230/460 V, 60 Hz / 200-220/380 V, 50 Hz	Part No. 913 68-2	Part No. 913 78-3	Part No. 913 88-2	Part No. 913 98-2

TRIVAC D 16 BCS-PFPE to D 65 BCS-PFPE

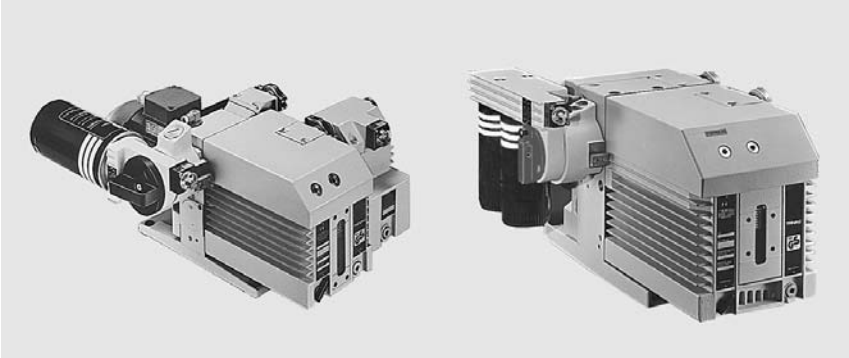

TRIVAC D 25 BCS-PFPE with CFS 16-25 and ARS 16-25 (left) and TRIVAC D 65 BCS-PFPE with CFS 40-65 (right)

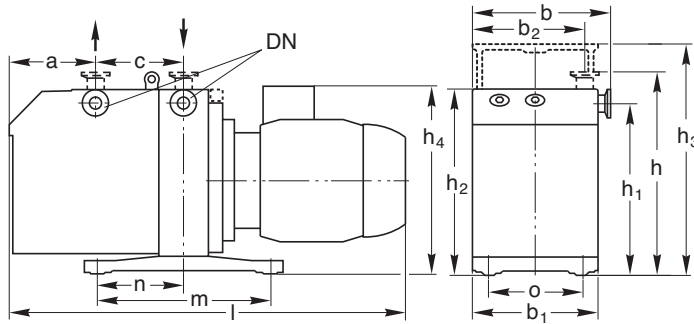

US pumps max. length
 D 16 BCS-PFPE: 560 mm (22.1")
 D 25 BCS-PFPE: 660 mm (26")
 D 40 BCS-PFPE: 760 mm (30")
 D 65 BCS-PFPE: 840 mm (33.1")

Type	DN	a	b	b ₁	b ₂	c	h	h ₁	h ₂	h ₃	h ₄	l	m	n	o	
D 16 BCS-PFPE (Part No. 113 69, 154 50)	25 KF	mm	82	190	175	150	135	263	226	250	298	262	506	280	140	132
		in.	3.23	7.48	6.89	5.91	5.32	10.35	8.90	9.84	11.73	10.32	19.96	11.02	5.51	5.20
D 25 BCS-PFPE (Part No. 113 79, 154 51)	25 KF	mm	142	190	175	150	135	263	226	250	298	262	567	280	140	132
		in.	5.59	7.48	6.89	5.91	5.32	10.35	8.90	9.84	11.73	10.32	22.32	11.02	5.51	5.20
D 40 BCS-PFPE (Part No. 113 89)	40 KF	mm	135	264	234	206	166	355	308	336	-	302	716	382	191	190
		in.	5.32	10.39	9.21	8.11	6.54	13.98	12.13	13.23	-	11.90	28.19	15.04	7.52	7.48
D 40 BCS-PFPE (Part No. 154 52)	40 KF	mm	135	264	234	206	166	355	308	336	-	302	716	382	191	190
		in.	5.32	10.39	9.21	8.11	6.54	13.98	12.13	13.23	-	11.90	28.19	15.04	7.52	7.48
D 65 BCS-PFPE (Part No. 113 99)	40 KF	mm	213	264	234	206	166	355	308	336	-	302	794	382	191	190
		in.	8.39	10.39	9.21	8.11	6.54	13.98	12.13	13.23	-	11.90	31.26	15.04	7.52	7.48
D 65 BCS-PFPE (Part No. 154 54)	40 KF	mm	213	264	234	206	166	355	308	336	-	302	794	382	191	190
		in.	8.39	10.39	9.21	8.11	6.54	13.98	12.13	13.23	-	11.90	31.26	15.04	7.52	7.48

Dimensional drawing for the TRIVAC D 16 to D 65 BCS-PFPE

Technical Data

TRIVAC

D 16 BCS-PFPE D 25 BCS-PFPE D 40 BCS-PFPE D 65 BCS-PFPE

two-stage two-stage two-stage two-stage

Nominal pumping speed 50/60 Hz ¹⁾	m ³ /h (cfm)	18.9 (11.1) / 22.7 (13.4)	29.5 (17.4) / 35.4 (20.9)	46 (27) / 55 (32.5)	75 (44) / 90 (53)
Pumping speed 50/60 Hz ¹⁾	m ³ /h (cfm)	16.5 (9.7) / 19.8 (11.7)	25.7 (15.1) / 30.8 (18.2)	40 (24) / 48 (28)	65 (38) / 78 (46)
Ultimate partial pressure without gas ballast ¹⁾	mbar (Torr)	< 8 x 10 ⁻⁴ (< 6 x 10 ⁻⁴)	< 8 x 10 ⁻⁴ (< 6 x 10 ⁻⁴)	< 8 x 10 ⁻⁴ (< 6 x 10 ⁻⁴)	< 8 x 10 ⁻⁴ (< 6 x 10 ⁻⁴)
Ultimate total pressure with gas ballast ¹⁾	mbar (Torr)	< 5 x 10 ⁻³ (< 3.8 x 10 ⁻³)	< 5 x 10 ⁻³ (< 3.8 x 10 ⁻³)	< 5 x 10 ⁻³ (< 3.8 x 10 ⁻³)	< 5 x 10 ⁻³ (< 3.8 x 10 ⁻³)
Ultimate total pressure with reduced gas ballast, 200 l x h ⁻¹ ¹⁾	mbar (Torr)	< 2 x 10 ⁻³ (< 1.5 x 10 ⁻³)	< 2 x 10 ⁻³ (< 1.5 x 10 ⁻³)	–	–
Lubricant filling min. / max. upon delivery	l (qt)	0.45 / 1.0 (0.5 / 1.1)	0.6 / 1.4 (0.6 / 1.5)	1.5 / 2.5 (1.6 / 2.6)	2.0 / 3.5 (2.1 / 3.7)
	l (qt)	0.2 (0.2)	0.4 (0.4)	0.6 (0.6)	0.75 (0.8)
Noise level ²⁾ to DIN 45 635, without / with gas ballast	dB(A)	52 / 54	52 / 54	57 / 59	57 / 59
Admissible ambient temperature	°C (°F)	+12 ³⁾ to +40 (+54 to +104)	+12 to +40 (+54 to +104)	+12 to +40 (+54 to +104)	+12 to +40 (+54 to +104)
Motor rating ²⁾	W (HP)	550 (0.75)	750 (1)	2200 (3)	2200 (3)
Nominal speed 50/60 Hz	rpm	1500 / 1800	1500 / 1800	1500 / 1800	1500 / 1800
Type of protection ⁴⁾	IP	55	55	55	55
Weight ²⁾	kg (lbs)	27 (59.5)	33 (72.8)	71 (156.6)	83 (183)
Connections, Intake and Exhaust	DN	25 KF	25 KF	40 KF	40 KF

¹⁾ To DIN 28 400 and following numbers

²⁾ Weight, motor rating and noise levels for the pumps with global version 3-phase motor, 50 Hz, only.

Any data that deviate from the above for pumps with other motors, and other motor-dependent data are given in section "Products", paragraph "Motor Dependent Data for the TRIVAC B, BCS and BCS-PFPE"

³⁾ Cold start temperature to DIN

⁴⁾ Global versions only. North and South American versions are TEFC

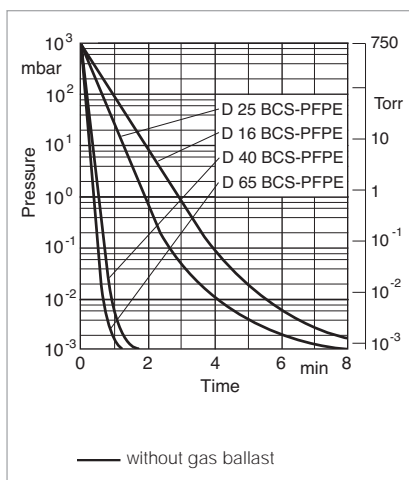

Pump-down characteristics of a 100 l vessel at 50 Hz

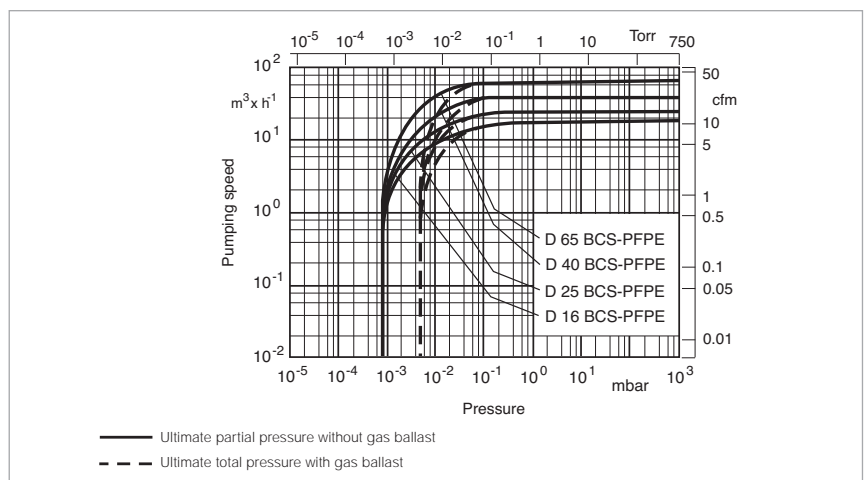

Pumping speed characteristics at 50 Hz (60 Hz curves at the end of the section)

Ordering Information

TRIVAC

D 16 BCS-PFPE D 25 BCS-PFPE D 40 BCS-PFPE D 65 BCS-PFPE

two-stage

two-stage

two-stage

two-stage

TRIVAC BCS-PFPE with 3-phase motor 230/400 V, 50 Hz / 250/440 V, 60 Hz 200/400 V, 50 Hz / 220/440 V, 60 Hz	Part No. 113 69 Part No. 154 50	Part No. 113 79 Part No. 154 51	Part No. 113 89 Part No. 154 52	Part No. 113 99 Part No. 154 54
---	--	--	--	--

Accessories

Roots pump adaptor	-	-	Part No. 168 30	Part No. 168 30
Exhaust filter with lubricant return ARS 16-25 ARS 40-65	Part No. 189 56 -	Part No. 189 56 -	- Part No. 189 57	- Part No. 189 57
Condensate trap AK 16-25 AK 40-65	Part No. 188 11 -	Part No. 188 11 -	- Part No. 188 16	- Part No. 188 16
Chemical filter with safety isolation valve CFS 16-25 CFS 40-65	Part No. 101 76 -	Part No. 101 76 -	- Part No. 101 77	- Part No. 101 77
Inert gas system IGS 16-25 IGS 40-65	Part No. 161 76 -	Part No. 161 76 -	- Part No. 161 77	- Part No. 161 77
Limit switch system LSS 16-25 LSS 40-65	Part No. 161 06 -	Part No. 161 06 -	- Part No. 161 07	- Part No. 161 07

Spare Parts

Inner body	Part No. 200 39 763	Part No. 200 39 765	-	Part No. 200 39 156
Major maintenance kit, PFPE (without oil)	Part No. EK 110 002 644	Part No. EK 110 002 645	Part No. EK 110 002 637	Part No. EK 110 002 638
Shaft sealing replacement kit	Part No. EK 110 002 650	Part No. EK 110 002 650	Part No. EK 110 002 643	Part No. EK 110 002 643
Small parts kit	-	-	Part No. EK 110 002 651	Part No. EK 110 002 651

Only available for purchase in North and South America

Ordering Information

TRIVAC

D 16 BCS-PFPE D 25 BCS-PFPE D 40 BCS-PFPE D 65 BCS-PFPE
two-stage two-stage two-stage two-stage

TRIVAC BCS-PFPE with 1-phase motor 115 V, 50/60 Hz, NEMA plug 208-230 V, 50/60 Hz, NEMA plug	Part No. 913 69-1 -	- Part No. 913 79-2	- -	- -
with 3-phase motor 208-230/460 V, 60 Hz / 200/380 V, 50 Hz	Part No. 913 69-2	Part No. 913 79-3	Part No. 913 89-2	Part No. 913 99-2

Motor Dependent Data for the TRIVAC B, BCS and BCS-PFPE

Ordering Information

	D 4 B	D 8 B
TRIVAC D 4 + 8 B	Part No. 140 081	Part No. 140 082
	Part No. 112 45	Part No. 112 55
	Part No. 112 46	Part No. 112 56
	Part No. 140 140	Part No. 140 150
	Part No. 912 45-1	-
	Part No. 912 45-2	-
	Part No. 912 46-2	-
	-	Part No. 912 55-1
	-	Part No. 912 55-2
	-	Part No. 912 56-2

	D 16 B D 16 BCS D 16 BCS-PFPE	D 25 B D 25 BCS D 25 BCS-PFPE
TRIVAC D 16 + 25 B (BCS(-PFPE))	-	Part No. 113 48
	-	-
	-	-
	Part No. 113 25	Part No. 113 35
	-	-
	-	-
	Part No. 112 65	-
	-	-
	-	-

	D 4/8 B	D 16/25	D 40	D 65 B	S 1,5
Shaft dimensions $\varnothing d / l$	14 / 30	19 / 40	28 / 60	28 / 60	11 / 23
Size of flange A/B	140 / 95	160 / 110	160 / 110	160 / 110	120 / 100

Type of protection	IP 54
Type of motor	B 14
Rotational speed 50/60 Hz	1500 / 1800

Ref. No. 1- or 3-ph	Motor voltage (V)	Frequency (Hz) ± 5%	Voltage range (V)	Power ((kW) / (HP))	Nominal current (A)	Size	Region
100 002 292 1 ~	100-120 200-240	50/60 50/60	100-120 200-240	0.57 0.66	7.7/5.6 4.0/2.8	80	World
380 66 008 1 ~	230	50	218-242	0.37 0.5	2.9	70	EURO
380 66 006 3 ~	230/400 250/440	50 60	218-242/380-420 240-277/415-480	0.37 0.5	1.95/1.12 1.73/1.0	70	EURO (US)
200 10 406 3 ~ Exe II CT3 (US)	230/400	50	219-242/380-420	0.37	1.84/1.06	71L	EURO
722 60 095 1 ~	115 110	60 50	103-126 99-121	0.25 0.33	7.0 8.8	NEMA 56 C	US
722 60 096 1 ~	200-230 200-220	60 50	180-253 180-220	0.25 0.33	3.2-3.5 3.6-4.4	NEMA 56 C	US
722 60 067 3 ~	200-230/460 200/380	60 50	180-253/414-506 180-220/342-418	0.25 0.33	1.5-1.6/0.8 1.6/0.8	NEMA 56 C	US
722 60 117 1 ~	115 115	60 50	103-126 103-126	0.55 0.75	9.4 13.0	NEMA 56 C	US
722 60 005 1 ~	208-230 208-230	60 50	187-253 187-253	0.55 0.75	4.8-4.7 5.5-6.5	NEMA 56 C	US
722 60 135 3 ~	208-230/460 208-220/380	60 50	187-253/414-506 187-242/342-418	0.75 1.0	3.4/1.7 3.1/1.7	NEMA 56 C	US

Ref. No. 1- or 3-ph	Motor voltage (V)	Frequency (Hz) ± 5%	Voltage range (V)	Power ((kW) / (HP))	Nominal current (A)	Size	Region
200 10 679 1 ~	115	60	109-121	0.75 1.0	12.5	90	US
110 001 212	230	50 60	208-252	0.75 1.0	5.7 4.9	90	Wide range
380 66 003	230	50	218-242	0.55 0.75	5.0	80	EURO

The right of technical alterations is reserved

Motor Dependent Data for the TRIVAC B, BCS and BCS-PFPE

Ordering Information

**D 16 B
D 16 BCS
D 16 BCS-PFPE**

**D 25 B
D 25 BCS
D 25 BCS-PFPE**

	-	Part No. 112 75
	-	-
	-	-
	Part No. 112 66 / 113 33 (RCF - E68N)	Part No. 112 76
	Part No. 113 68	
		Part No. 113 78
	Part No. 113 69	Part No. 113 79
	Part No. 140 160	Part No. 140 170
	-	-
	-	-
	Part No. 113 34 (RCF - E68N)	-
	-	-
	-	-
	Part No. 114 06 DOT / 114 10 DOT LSS	-
	-	-
	-	-
	-	-
	Part No. 154 50	Part No. 154 51
	Part No. 912 65-1	-
	-	-
	Part No. 913 69-1	-
	Part No. 912 65-2	-
	-	-
	-	-
	Part No. 912 66-2	-
	Part No. 913 68-2	-
	Part No. 913 69-2	-
	-	Part No. 912 75-2
	-	-
	-	Part No. 913 79-2
	-	Part No. 912 76-2
	-	Part No. 913 78-3
	-	Part No. 913 79-3
	-	Part No. 912 75 V 001
	-	-
	-	-

**TRIVAC D 16 + 25 B
(BCS(-PFPE))**

	D 4/8 B	D 16/25	D 40	D 65 B	S 1,5
Shaft dimensions $\varnothing d / l$	14 / 30	19 / 40	28 / 60	28 / 60	11 / 23
Size of flange A/B	140 / 95	160 / 110	160 / 110	160 / 110	120 / 100

Type of protection	IP 54
Type of motor	B 14
Rotational speed 50/60 Hz	1500 / 1800

Ref. No. 1- or 3-ph	Motor voltage (V)	Frequency (Hz) ± 5%	Voltage range (V)	Power (kW) / (HP)	Nominal current (A)	Size	Region
110 001 200	230	50 60	218-242	0.55 0.75	5.0 4.2	80	EURO
380 66 002 3 ~	230/400 250/440	50 60	218-242/380-420 240-277/415-480	0.75 1.0	3.8/2.05 4.3/2.5	80	EURO (US)
380 66 001 3 ~	230/400 250/440	50 60	212-242/380-420 240-277/415-480	0.55 1.0	2.85/1.65 2.5/1.45	70	EURO (US)
380 66 002 3 ~	230/400 250/440	50 60	218-242/380-420 240-277/415-480	0.75 1.0	3.8/2.05 4.3/2.5	80	EURO (US)
380 66 002 3 ~	230/400 250/440	50 60	218-242/380-420 240-277/415-480	0.75 1.0	3.8/2.05 4.3/2.5	80	EURO (US)
200 10 409 3 ~ Exe II CT3	230/400	50	218-242/380-420	0.75 1.0	3.4/1.97	80	EURO
200 10 410 3 ~	200/346 208/360	50 60	190-210/330-365 190-230/330-400	0.75 1.0	4.3/2.5 4.3/2.5	80	Japan, South and Central America, US
200 10 299 3 ~	230/400 250/440	50 60	218-242/380-420 240-265/415-460	0.55 0.75	3.2/1.85 2.8/1.6	70	EURO
100 000 807 3 ~	200/400 220/440	50 60	190-220/380-440 190-240/380-480	0.75 1.0	4.3/2.15 4.0/2.0	80	Wide range
722 60 117 1 ~	115 115	60 50	103-126 103-126	0.55 0.75	9.4 13.0	NEMA 56 C	US
722 60 005 1 ~	208-230 208-230	60 50	187-253 187-253	0.55 0.75	4.8-4.7 5.5-6.5	NEMA 56 C	US
722 60 135 3 ~	208-230/460 208-220/380	60 50	187-253/414-506 187-242/342-418	0.75 1.0	3.4-3.4/1.7 3.1/1.7	NEMA 56 C	US
722 60 022 1 ~	200-230 200-230	50 60	180-253 180-253	1.1 1.5 1.1 1.5	9.5-9.2 9.0-8.0	NEMA 56 C NEMA 56 C	US US
722 60 071 3 ~	200-230/460 200/380	60 50	180-253/414-506 180-220/342-418	1.1 1.5	9.0-8.0 9.6-9.2	NEMA 56 C	US
722 60 186 1 ~	115	60	103-126	1.1 1.5	18.0	NEMA 56 C	US

The right of technical alterations is reserved

Motor Dependent Data for the TRIVAC B, BCS and BCS-PFPE

Ordering Information

**D 40 B
D 40 BCS
D 40 BCS-PFPE**

**D 65 B
D 65 BCS
D 65 BCS-PFPE**

**TRIVAC
D 40 + 65 B
(BCS(-PFPE))**

Part No. 112 86	Part No. 112 96
Part No. 113 88	Part No. 113 98
Part No. 113 89	Part No. 113 99
Part No. 140 180	Part No. 140 190
-	-
-	-
Part No. 113 47	Part No. 113 57
-	-
-	-
-	-
Part No. 154 52	Part No. 154 54
Part No. 912 86-2	Part No. 912 96-2
-	-
-	-

	D 4/8 B	D 16/25	D 40	D 65 B	S 1,5
Shaft dimensions $\varnothing d / l$	14 / 30	19 / 40	28 / 60	28 / 60	11 / 23
Size of flange A/B	140 / 95	160 / 110	160 / 110	160 / 110	120 / 100

Type of protection	IP 54
Type of motor	B 14
Rotational speed 50/60 Hz	1500 / 1800

Ref. No. 1- or 3-ph	Motor voltage (V)	Frequency (Hz) ± 5%	Voltage range (V)	Power (kW) / (HP)	Nominal current (A)	Size	Region
380 66 012 3 ~	230/400 250/440	50 60	218-242/380-420 240-277/414-480	2.2 3.0	9.9/5.7 8.5/4.9	100	EURO (US)
200 10 411 3 ~ Exe II CT3	230/400	50	218-242/380-420	2.5 3.4	9.4/5.4	100	EURO
200 10 412 3 ~	200/346 208/360	50 60	190-210/330-365 190-230/330-400	2.2 3.0	10.1/5.85 10.1/5.85	90	Japan, South and Central America, US
200 15 402 3 ~	200/400 220/440	50 60	190-220/380-440 190-240/380-480	2.2 3.0	15.0/7.5 11.5/5.9	100	Wide range
110 004 011 3 ~	200-230/460 200-220/380-415	60 50	180-253/414-506 180-242/342-418	2.2 3.0	9.0-8.4/4.2 9.4-9.6/4.6-4.7	NEMA 182 TC	US

The right of technical alterations is reserved

Accessories

For TRIVAC E, B and BCS

Exhaust Filter Drain Tap

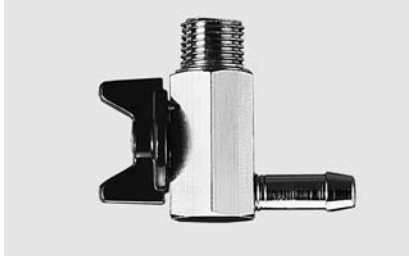

The exhaust filter drain tap simplifies draining of the oil from the exhaust filter.

Technical Note

May also be used in connection with the condensate separator AK.

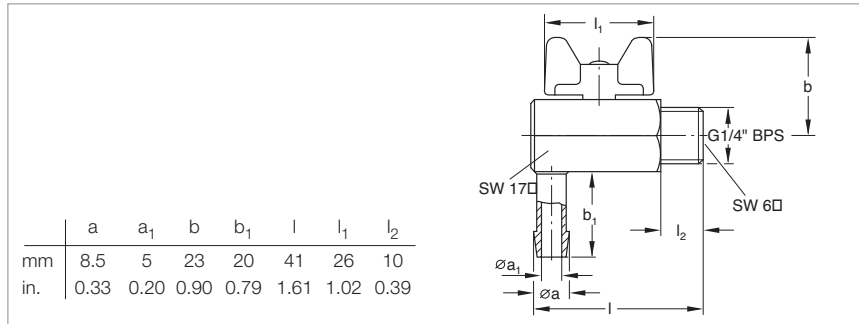

Dimensional drawing for the exhaust filter drain tap

Technical Data

Leak rate	mbar x l x s ⁻¹	≤ 10 ⁻⁵
-----------	----------------------------	--------------------

Exhaust Filter Drain Tap

Ordering Information

Exhaust filter drain tap	Part No. 190 95
--------------------------	------------------------

Exhaust Filter Drain Tap

Oil Drain Tap



This oil drain tap may be screwed into the oil drain when wanting to change the oil in the rotary vane pumps. It is also suited for the condensate separators and exhaust filters of the TRIVAC B series.

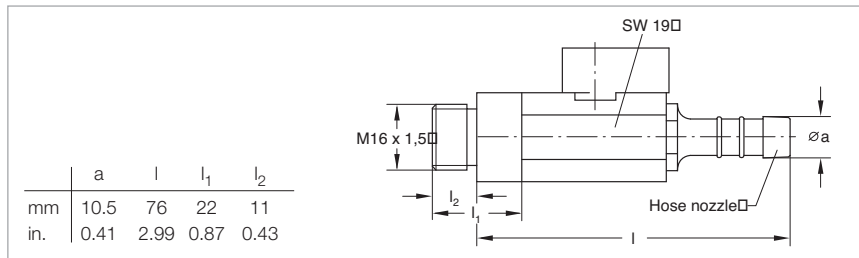

Dimensional drawing for the oil drain tap

Technical Data

Leak rate	mbar x l x s ⁻¹	≤ 10 ⁻⁵
-----------	----------------------------	--------------------

Oil Drain Tap

Ordering Information

Oil drain tap	Part No. 190 90
---------------	------------------------

Oil Drain Tap

Oil Drain Kit

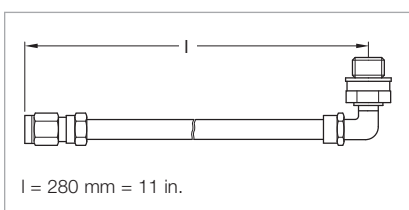

Dimensional drawing for the oil drain kit

Technical Data

Length	mm (in.)	280 (11)
Leak rate	mbar x l x s ⁻¹	≤ 10 ⁻⁵

Oil Drain Kit

Ordering Information

Oil drain kit	Part No. 190 94
---------------	------------------------

Oil Drain Kit

Oil Suction Facility AR-V Controlled by Solenoid Valve

Suited for the AF 8 or AK 8 when connected to the D 2.5 E or NT 5, NT 10, NT 16 and NT 25 the oil suction facility AR-V with its solenoid valve allows the removal of oil via the gas ballast which has collected in the exhaust filter. When the valve is closed the gas ballast remains fully operational. For this, a hose link is provided between the exhaust filter and the gas ballast.

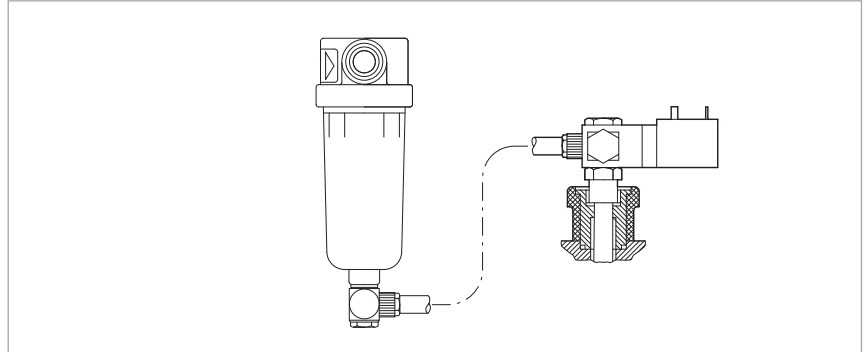

AR-V oil suction facility controlled by solenoid valve (kit without exhaust filter)

Technical Note

If oil which has collected in the exhaust filter is to be removed, the solenoid valve is opened briefly.

Technical Data

AR-V Oil Suction Facility Controlled by Solenoid Valve

Leak rate	$\text{mbar} \times \text{l} \times \text{s}^{-1}$	$\leq 10^{-5}$
-----------	--	----------------

Ordering Information

AR-V Oil Suction Facility Controlled by Solenoid Valve

AR-V oil suction facility controlled by solenoid valve 24 V DC, 4 W, normally closed	Part No. 190 92
--	------------------------

Manually Operated Oil Suction Facility AR-M

Suited for the AF 8 or AK 8 when connected to the D 2,5 E or NT 5, NT 10, NT 16 and NT 25, the oil suction facility AR-M allows the removal of oil via the gas ballast which has collected in the exhaust filter, whereby the gas ballast remains fully operational as long as the angled ball valve remains closed. For this, a hose link is provided between the exhaust filter and the gas ballast.

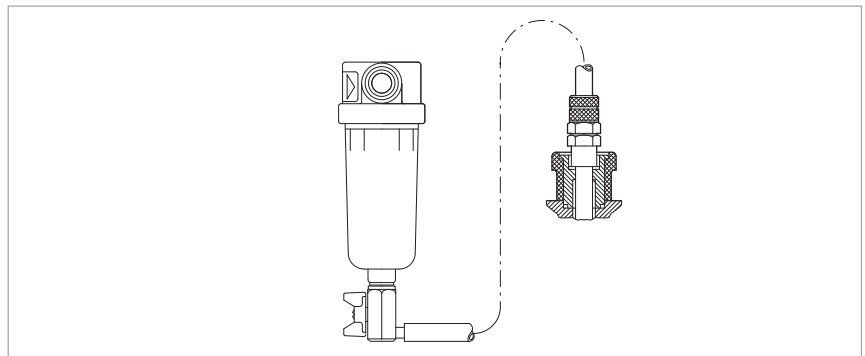

AR-M manually operated oil suction facility (kit without exhaust filter)

Technical Note

If oil which has collected in the exhaust filter is to be removed, the angled ball valve is manually opened briefly.

Technical Data

AR-M Manually Operated Oil Suction Facility

Leak rate	$\text{mbar} \times \text{l} \times \text{s}^{-1}$	$\leq 10^{-5}$
-----------	--	----------------

Ordering Information

AR-M Manually Operated Oil Suction Facility

AR-M manually operated oil suction facility	Part No. 190 93
---	------------------------

Exhaust Filters AF 8, AF 10, AF 16, AF 25

Condensate Traps AK 8, AK 10, AK 16, AK 25



Exhaust filter (left) and condensate trap (right)

Exhaust-Filter

Oil mists and aerosols are retained in the exhaust filter.

Advantages to the User

- Filtering of the exhaust gas by removal of entrained lubricant particles
- Emptying via drain screw or exhaust filter drain tap
- Separation efficiency > 99%
- Filter elements (made of glass fiber) are exchangeable

Condensate Trap

Condensate traps prevent the formation of condensate in the pump as well as the backstreaming of fluids.

Advantages to the User

- Can be connected to either the intake or the exhaust side
- Protects against condensate forming from sucked in vapors or gases (intake line)
- Protects against backstreaming liquids (exhaust line)
- Emptying via drain screw/drain tap

Technical Information

The exhaust filter is not capable of retaining toxic and/or aggressive gases. For such applications we recommend the use of an exhaust gas line (e.g. a gas washer).

Since the material is not resistant to all gases and solvents, a materials compatibility chart is available upon request.

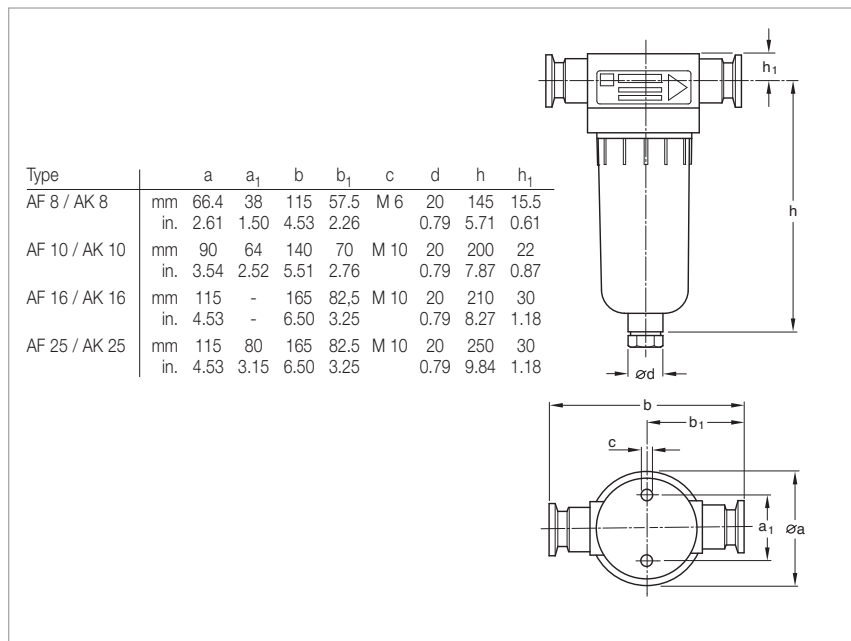

Technical Data

AF 8 AK 8 AF 10 AK 10 AF 16 AK 16 AF 25 AK 25

Connection to pump (required accessories for TRIVAC NT and E: elbow)	TRIVAC	NT 5 ¹⁾ D 2,5 E D 4 B D 8 B	NT 5 ¹⁾ D 2,5 E D 4 B D 8 B	NT 10	NT 10	NT 16 D 16 B	NT 16 D 16 B	NT 25 D 16 B D 25 B	NT 25 D 16 B D 25 B
Connection flanges	DN	16 KF	16 KF	25 KF	25 KF	25 KF	25 KF	25 KF	25 KF
Max. filling level (for vertical installation)	ml (qt)	60	60	145	145	285	285	285	285
Permissible leak rate	mbar x l x s ⁻¹	≤ 1 x 10 ⁻⁵	≤ 1 x 10 ⁻⁵	≤ 1 x 10 ⁻⁵	≤ 1 x 10 ⁻⁵	≤ 1 x 10 ⁻⁵	≤ 1 x 10 ⁻⁵	≤ 1 x 10 ⁻⁵	≤ 1 x 10 ⁻⁵
Max. continuous temperature	°C (°F)	90	90	90	90	90	90	90	90
Material		Polyamide 6	Polyamide 6	Polyamide 6	Polyamide 6	Polyamide 6	Polyamide 6	Polyamide 6	Polyamide 6

Ordering Information

AF 8 AK 8 AF 10 AK 10 AF 16 AK 16 AF 25 AK 25

	Part No.	Part No.	Part No.	Part No.	Part No.	Part No.	Part No.	Part No.
Exhaust filter	190 50	-	190 51	-	190 52	-	190 53	-
Exhaust filter drain tap	190 95	190 95	190 95	190 95	190 95	190 95	190 95	190 95
Condensate trap	-	190 60	-	190 61	-	190 62	-	190 63
Replacement filter element (pack of 5)	ES 190 80	-	-	-	-	-	-	-
FE 8	-	-	ES 190 81	-	-	-	-	-
FE 10	-	-	-	-	ES 190 82	-	-	-
FE 16	-	-	-	-	-	-	-	-
FE 25	-	-	-	-	-	-	ES 190 83	-
Exhaust flange, horizontal; DN 16 KF for TRIVAC NT 5/10	140 103	140 103	140 103	140 103	-	-	-	-
for TRIVAC NT 16/25	-	-	-	-	140 301	140 301	140 301	140 301
Reducer DN 25/16 KF ²⁾ Aluminum (if necessary)	183 86	183 86	183 86	183 86	183 86	183 86	183 86	183 86
Elbow (1x) Aluminum	184 36	184 36	184 37	184 37	184 37	184 37	184 37	184 37
Centering ring with O-ring (2x) aluminium / NBR	183 26	183 26	183 27	183 27	183 27	183 27	183 27	183 27
stainless steel / FPM (FKM)	883 46	883 46	883 47	883 47	883 47	883 47	883 47	883 47
Clamping ring (2x)	183 41	183 41	183 42	183 42	183 42	183 42	183 42	183 42

¹⁾ A reducer DN 25/16 KF is required

²⁾ When using the reducer, an elbow is required

Exhaust Filters with Lubricant Return

ARP 4-8, AR 4-8, AR 16-25, AR 40-65



AR 4-8 exhaust filter with lubricant return



ARP 4-8 exhaust filter with lubricant return

This combination of an exhaust filter with a float-controlled valve considerably extends the maintenance intervals for the TRIVAC pumps.

Advantages to the User

- Filtering the exhaust air of entrained lubricant particles
- Lubricant return with the aid of a float-controlled valve back into the intake port
- No operating costs caused by lost lubricant
- Hardly any oil consumption
- Standard filter element
- Built-in over-pressure relief valve
- Resists solvents
- All seals made of FPM (FKM)
- The top head may be easily rotated (either parallel or perpendicular to bottom body)
[only AR 4-8 to AR 16-25]

Typical Application

- Extending the maintenance intervals

Supplied Equipment

Intermediate flange, connecting lines with hollow screws, required gaskets as well as mounting screws for the intake flange.

Technical Information

The AR is connected to the exhaust port of the TRIVAC B, the return line is connected at the intermediate flange under the intake port.

An exhaust line must be connected in case of hazardous exhaust gases.

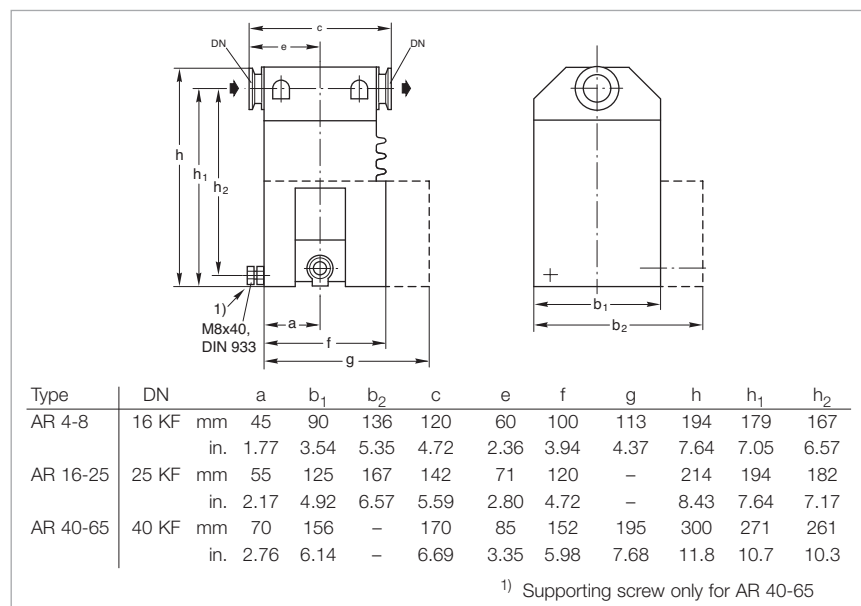

Dimensional drawing for the AR exhaust filters with lubricant return
(dimensions for the ARP exhaust filter with lubricant return upon request)

Technical Data

ARP 4-8 AR 4-8 AR 16-25 AR 40-65

Connection to pump	TRIVAC	NT 5/10	D 4/8 B	D 4/8 B	NT 16/25 ¹⁾	D 16/25 B/BCS	D 40/65 B/BCS
For opening the float-controlled valve	required amount of oil N 62	cm ³ (qt)	-	430 (0.45)	510 (0.54)	760 (0.80)	
	remaining amount of oil N 62	cm ³ (qt)	-	350 (0.37)	430 (0.45)	700 (0.74)	
Weight	kg (lbs)	1.7 (3.8)	3.1 (6.89)	4.7 (10.4)	8.5 (18.7)		

Ordering Information

ARP 4-8 AR 4-8 AR 16-25 AR 40-65

Exhaust filter with lubricant return	Part No.	Part No.	Part No.	Part No.
		140 065	189 20	189 21
Replacement filter element				
FE 8	190 80	-	-	-
FE 4-8	-	189 71	-	-
FE 16-25	-	-	189 72	-
FE 40-65	-	-	-	189 73

¹⁾ Adapter is necessary for NT pumps. See Ordering Information for the TRIVAC NT pumps

Exhaust Filters with Lubricant Return

ARS 16-25 and ARS 40-65



ARS 40-65

This combination of an exhaust filter with a float-controlled valve considerably extends the maintenance intervals of the TRIVAC BCS.

The ARS is part of the TRIVAC SYSTEM.

Advantages to the User

- Lubricant return with the aid of a float-controlled valve back into the intake port
- The intake port may be easily exchanged (either vertical or horizontal orientation)
- No operating costs caused by lost lubricant
- Hardly any oil consumption
- Visual indication of the differential pressure
- Standard filter element
- All aluminium parts are surface protected
- Built-in over-pressure relief valve
- Resists solvents
- All seals made of FPM (FKM)
- May also be used on the TRIVAC B and NT 16/25

Typical Application

- Filtering the exhaust air of entrained lubricant particles

Technical Information

An exhaust line must be connected in case of hazardous exhaust gases.

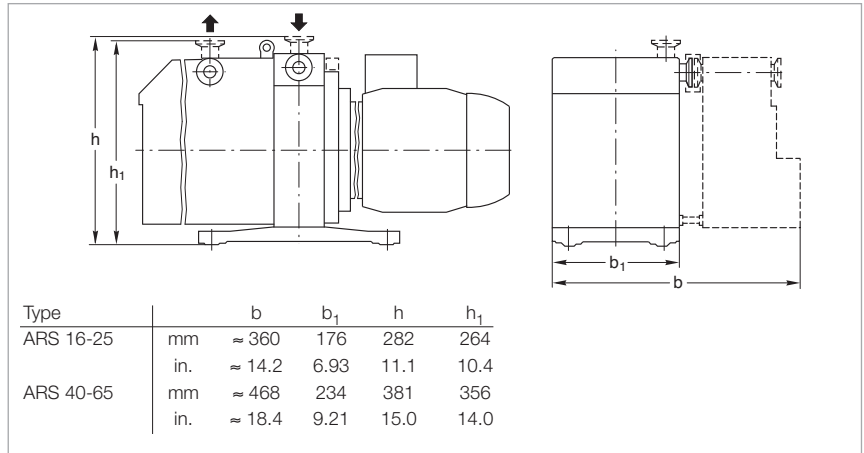

Dimensional drawing for the ARS mounted on a TRIVAC BCS

The ARS is connected to the exhaust port of the TRIVAC BCS, the return line is connected at the intermediate flange under the intake port.

The ARS is cleaned in the factory to such an extent, that it may be operated either with mineral oil (e.g. N 62 or HE-200) or perfluoropolyther (PFPE e.g. NC 1/14 or HE-1600).

Supplied Equipment

Intermediate flange, connecting lines with hollow screws, required gaskets as well as mounting screws for the intake flange.

Wrapped in foil for shipping.

Technical Data

ARS 16-25

ARS 40-65

Connection to pump	TRIVAC	NT 16/25 D 16/25 B; D 16/25 B/BCS (-PFPE)	D 40/65 B/BCS (-PFPE)
Connection flanges	DN	25 KF	40 KF
Amount of oil required for opening the float-controlled valve	N 62/HE-200	cm ³ (qt)	510 (0.54)
	PFPE	cm ³ (qt)	340 (0.36)
Remaining amount of oil	N 62/HE-200	cm ³ (qt)	430 (0.45)
	PFPE	cm ³ (qt)	300 (0.31)
Weight with intermediate flange, tubing and filter, without lubricant	kg (lbs)	4.7 (10.4)	8.5 (16.7)

Ordering Information

ARS 16-25

ARS 40-65

Exhaust filter with lubricant return	Part No. 189 56	Part No. 189 57
Replacement filter element		
FE 16-25	Part No. 189 72	-
FE 40-65	-	Part No. 189 73

Exhaust Filters

AF 4-8, AF 16-25, AF 40-65



AF 4-8 exhaust filter

Exhaust filters retain oil mists and aerosols.

Advantages to the User

- Can be fitted without additional accessories
- Separation efficiency over 99 %
- Exchangeable filter inserts
- Built-in over-pressure relief valve (threshold at about 1.5 bar (7.2 psi, differential))
- Sight glass for checking of the quantity of collected oil
- Resistant against solvents
- All seals made of FPM (FKM)
- Easy to clean and use
- Retains dirt and cracked products

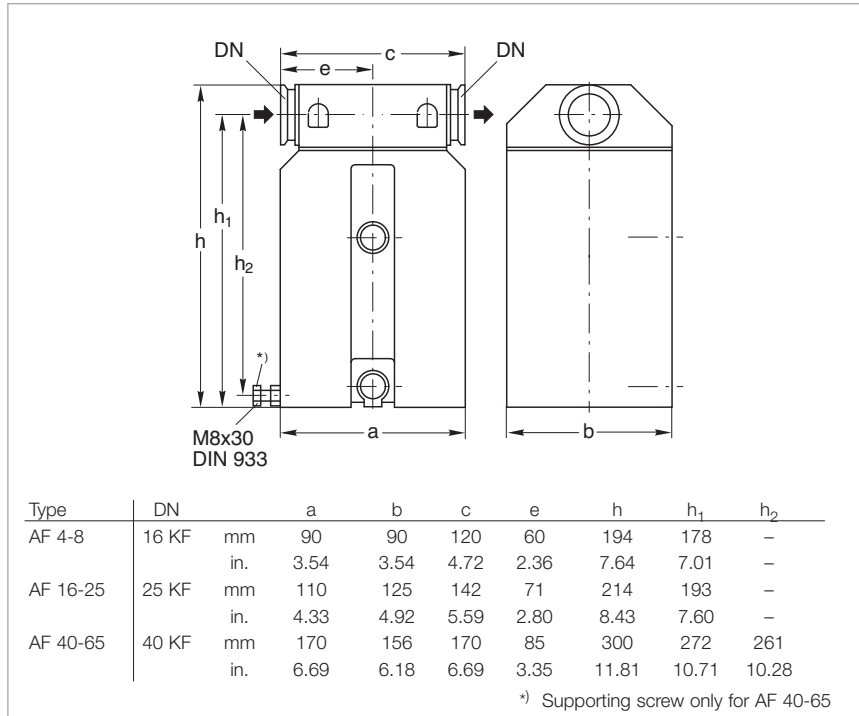

Dimensional drawing for the AF exhaust filter

Typical Application

- Improvement of oil separating capacity

Technical Information

An exhaust line must be connected in case of hazardous exhaust gases.

Technical Data**AF 4-8****AF 16-25****AF 40-65**

Connection to pump	TRIVAC	NT 5/10 ¹⁾ D 4/8 B	NT 16/25 D 16/25 B/BCS	D 40/65 B/BCS
Max. capacity for condensate, approx.	l (qt)	0.4 (0.45)	0.5 (0.57)	1.0 (1.14)
Weight	kg (lbs)	1.9 (4.1)	3.2 (7.1)	6.5 (14.3)

Ordering Information**AF 4-8****AF 16-25****AF 40-65**

Exhaust filter		Part No. 189 06	Part No. 189 11	Part No. 189 16
Replacement filter element				
FE 4-8		Part No. 189 71	-	-
FE 16-25		-	Part No. 189 72	-
FE 40-65		-	-	Part No. 189 73
Oil drain tap M 16 x 1.5 (vacuum-tight)		Part No. 190 90	Part No. 190 90	Part No. 190 90

Technical Data**AF 16-25 DOT**

Connection to pump	TRIVAC	-	NT 16/25 D 16/25 B-DOT	-
		-		-

Ordering Information**AF 16-25 DOT**

Exhaust filter		-	Part No. 124 16	-
Replacement filter element				
FE 16-25 DOT		-	Part No. 200 10 304	-

¹⁾ Reducer and elbow for installation required

Condensate Separators

AK 4-8, AK 16-25, AK 40-65



AK 4-8 condensate separator

Separators protect the pump against condensate

Advantages to the User

- May be installed without accessories
- May be used either on the intake or the exhaust side ¹⁾
- Independent of the direction of flow
- Condensate level check via inspection glass
- Resists solvents
- All seals made of FPM (FKM)
- Simple to clean
- Easy to use
- Drained via drain screw or drain tap

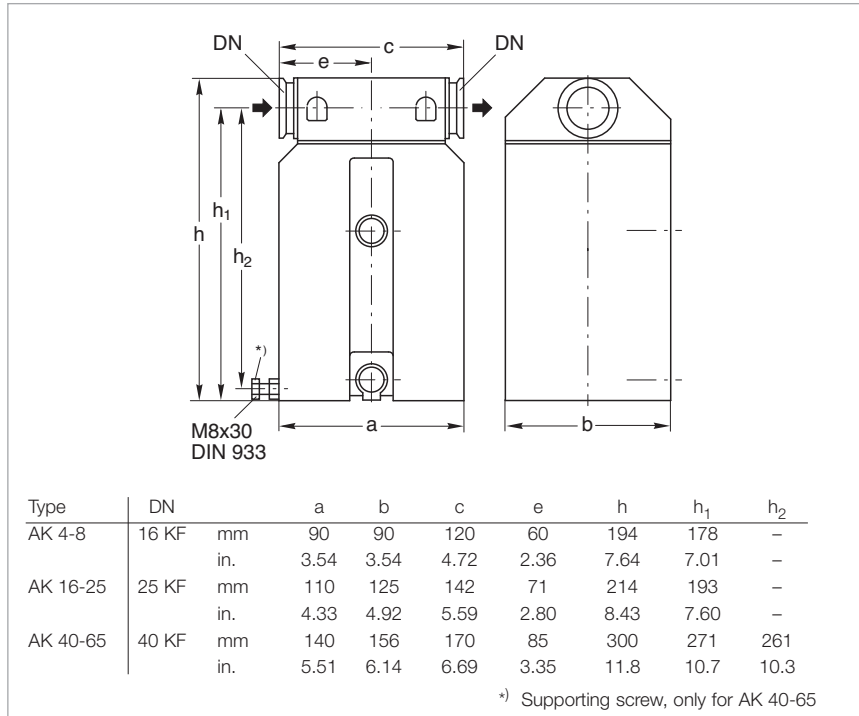

Dimensional drawing for the AK condensate separators

Typical Application

- Prevention of the collection of liquids in the intake line

Technical Information

Depending upon the layout and pipe run of an exhaust line, it may be necessary to install a separator to prevent condensate draining back to the pump.

Technical Data

		AK 4-8	AK16-25	AK 40-65
Connection to pump	TRIVAC	NT 5/10 ¹⁾ D 4 B D 8 B	NT 16/25 ¹⁾ D 16 B/BCS (-PFPE) D 25 B/BCS (-PFPE)	D 40 B/BCS (-PFPE) D 65 B/BCS (-PFPE)
Capacity for condensate	l (qt)	0.66 (0.7)	1.2 (1.3)	3.0 (3.2)
Weight	kg (lbs)	1.7 (3.7)	2.4 (5.3)	5.5 (12.1)

Ordering Information

	AK 4-8	AK16-25	AK 40-65
Condensate separator	Part No. 188 06	Part No. 188 11	Part No. 188 16
Oil drain tap M 16 x 1.5 (vacuum-tight)	Part No. 190 90	Part No. 190 90	Part No. 190 90
Adaptor DN 16 KF – hose nozzle DN 7	Part No. 182 90	-	-

¹⁾ For TRIVAC NT special exhaust flanges or inlet flanges are needed. See Ordering Information for the TRIVAC NT

Dust Filters

FS 2-4, FS 8-16, FS 30-60



Dust filter

The dust filters protect the pumps against the intake of dust.

Advantages to the User

- Easy to disassemble
- Vacuum-tight cast iron casing
- Replacement filters may be easily exchanged
- Separates dusts from a grain size of 1 μm

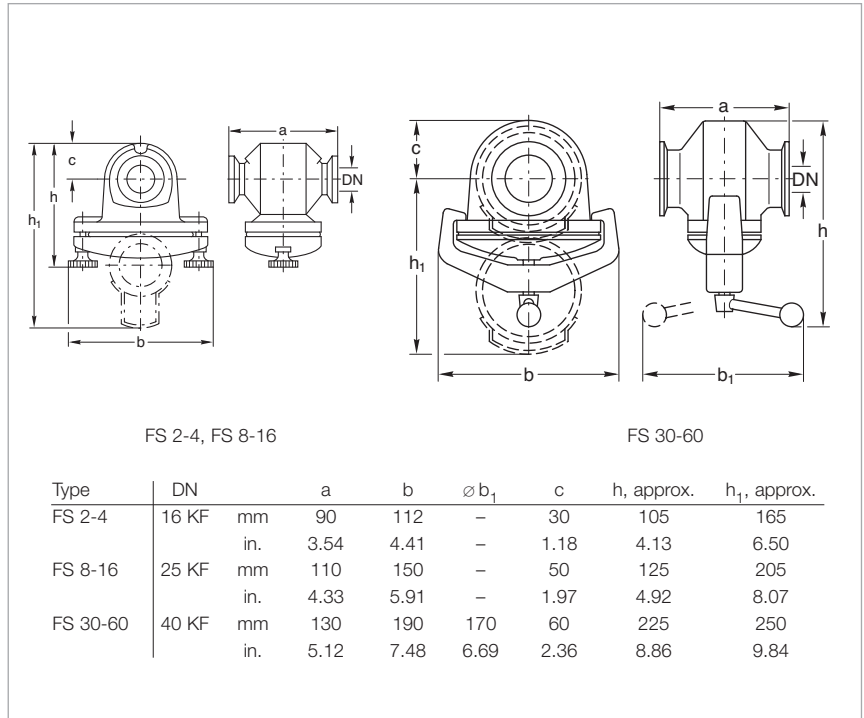

Dimensional drawing for the FS dust filters

Technical Information

Installing a dust filter in the intake line of the pump will throttle its pumping speed at low intake pressures more than at higher intake pressures. This must be taken into account when designing a vacuum system.

Since the dust filters have only a small dust collecting chamber, we recommend – in the case of larger dust quantities – the two-stage dust separators from the AS range.

The dust filters should be installed in a horizontal flow so that the filter insert may be removed by pulling it down and out.

Technical Data

FS 2-4 FS 8-16 FS 30-60

Connection to pump	TRIVAC	NT 5 ¹⁾		NT 10 ¹⁾		NT 25		NT 16	
		D 2,5 E	D 4 B	D 8 B	D 16 B	D 25 B	D 40 B	D 65 B	
Throttling of the pumping speed									
	at 1 mbar (0.75 Torr), approx.	%	6	10	12	18	12	25	
at 10 mbar (7.5 Torr), approx.	%	4	7	6	9	3	8		
Weight	kg (lbs)	1.0 (2.2)	1.0 (2.2)	1.6 (3.5)	1.6 (3.5)	7.5 (16.5)	7.5 (16.5)		

Ordering Information

FS 2-4 FS 8-16 FS 30-60

Dust filter	Part No. 186 05	Part No. 186 10	Part No. 186 15
Replacement filter insert	Part No. 178 32	Part No. 178 33	Part No. 178 35
Replacement wadding cartridges (1 set = 10 pieces)	Part No. 200 39 050	Part No. 200 39 051	Part No. 971 78 251

¹⁾ Reducer and elbow for installation required

Dust Separators AS 8-16 and AS 30-60 / Molecular Filters MF 8-16 and MF 30-60



AS 30-60 dust separator
(MF 30-60 molecular filter is similar)

Dust separators protect pumps against contamination and damage by sucked-in dust.

Advantages to the User

- Dust separators for large quantities of dust
- Two-stage, thus hardly any throttling
- Cyclone (for coarse dust) and wet filter (for fine dust)
- Dust separator and molecular filter have the same housing (for easy conversion)

Typical Application

- Separation of coarse and medium size dust starting at a grain size of 2 μm .

Technical Information

Installing a dust filter in the intake line of the pump will throttle its pumping speed at low intake pressures more than at higher intake pressures. This must be taken into account when designing a vacuum system.

Even when large quantities of dust are deposited, the throttling effect will hardly increase.

Supplied Equipment

Blanked off drain port.

Molecular filters are used to separate vapors of a high molecular weight (i.e. monomers, vapors from resins).

Advantages to the User

- Molecular filter and dust separator have the same housing (for easy conversion)
- Separation of high-molecular weight vapors
- Protection of the pump's oil against damaging vapors

Technical Information

Installing a molecular filter in the intake line of the pump will throttle its pumping speed at low intake pressures more than at higher intake pressures. This must be taken into account when designing a vacuum system.

Supplied Equipment

Blanked off drain port.

Technical Data

AS 8-16

AS 30-60

MF 8-16

MF 30-60

Connection to pump	TRIVAC	NT 16 D 16 B	NT 25 D 25 B	D 40 B	D 65 B	NT 16 D 16 B/BCS	NT 25 D 25 B/BCS	D 40 B/BCS	D 65 B/BCS
Throttling of the pumping speed at 1 mbar (0.75 Torr) intake pressure, approx.	%	10	15	8	16	10	15	8	16
at 10 mbar (7.5 Torr) intake pressure, approx.	%	5	7	4	9	5	7	4	9
Capacity for dust	l (qt)	0.6 (0.6)	0.6 (0.6)	2.0 (2.1)	2.0 (2.1)	–	–	–	–
Capacity for resin vapors or similar	kg (lbs)	–	–	–	–	0.15 (0.3)	0.15 (0.3)	0.35 (0.8)	0.35 (0.8)
Impact ring filling	l (qt)	0.5 (0.5)	0.5 (0.5)	3.5 (3.7)	3.5 (3.7)	–	–	–	–
Active charcoal filling	kg (lbs)	–	–	–	–	0.6 (1.3)	0.6 (1.3)	1.4 (3.1)	1.4 (3.1)
Weight	kg (lbs)	4.5 (9.9)	4.5 (9.9)	18.4 (40.6)	18.4 (40.6)	4.5 (9.9)	4.5 (9.9)	18.4 (40.6)	18.4 (40.6)

Ordering Information

AS 8-16

AS 30-60

MF 8-16

MF 30-60

Dust separator	Part No. 186 11	Part No. 186 16	–	–
Molecular filter	–	–	Part No. 186 12	Part No. 186 17
Replacement filter insert	–	Part No. 178 43	–	–
Replacement active charcoal insert	–	–	Part No. 178 07	Part No. 178 08
Active charcoal, undried, 5 kg (11 lbs)	–	–	Part No. 178 10	Part No. 178 10

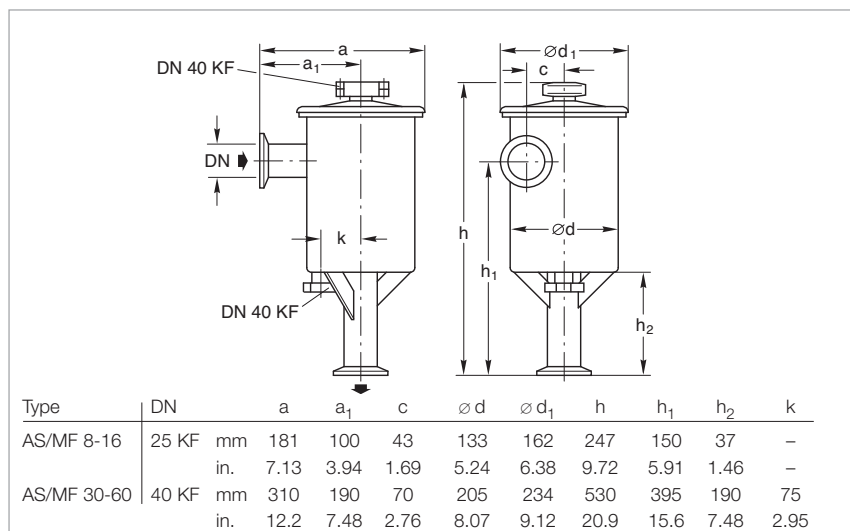

Dimensional drawing for the AS dust separators and MF molecular filters

Cold Trap TK 4-8



TK 4-8 cold trap

The cold trap protects the pump against damaging vapors.

Advantages to the User

- Rugged and implosion resistant
- May be fitted directly on the flange of the pump
- Safe draining of the condensate without problems
- Casing made of corrosion resistant stainless steel
- Simple filling with refrigerant (liquid nitrogen (LN₂) or a mixture of acetone and carbon di-oxide ice)

Typical Applications

- Prevention of oil from backstreaming into the vacuum system when operating at ultimate pressure
- Freezing of gases and vapors in the laboratory

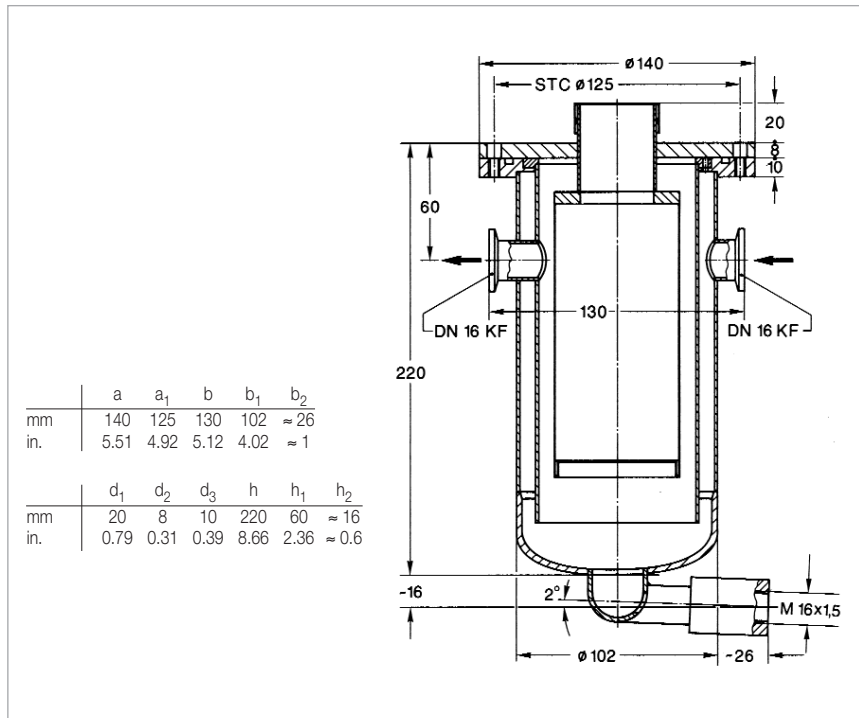

Dimensional drawing for the TK 4-8 cold trap

Technical Data

TK 4-8

Connection to pump	TRIVAC	D 2,5 E / D 4/8 B NT 5/10 ¹⁾
Capacity for refrigerant, approx.	l (qt)	0.4 (0.4)
Connections	DN	16 KF
Weight	kg (lbs)	4 (8.8)

Ordering Information

TK 4-8

Cold trap	Part No. 188 20
Drain tap for the intake side, vacuum-tight	Part No. 190 90
Elbow (1x)	Part No. 184 36
Centering ring aluminum/NBR (2x) stainless steel/FPM (FKM) (2x)	Part No. 183 26 Part No. 883 46
Clamping ring (2x)	Part No. 183 41

¹⁾ Reducer and elbow for installation required

Fine Vacuum Adsorption Traps FA 2-4, FA 8-16, FA 30-60



Heating rod and fine vacuum adsorption trap

Fine vacuum adsorption traps are vacuum-tight vessels which offer a high adsorption capacity especially for water vapor.

Advantages to the User

- Total pressures of 1.5×10^{-5} mbar (1.125×10^{-5} Torr) can be attained with a two-stage rotary vane vacuum pump
- Zeolite filling can be easily regenerated (baked at $300\text{ }^{\circ}\text{C}$ ($572\text{ }^{\circ}\text{F}$))
- High conductance

Typical Application

- Producing a vacuum which is free of water vapor

Technical Information

Liquid nitrogen in the adsorption trap will increase its adsorption capacity.

The conductance of the adsorption trap is higher than the pumping speed of the corresponding pump. See figure where the average pressure ahead and after the fine vacuum adsorption trap is plotted on the horizontal axis.

The adsorption traps may be installed in the intake line.

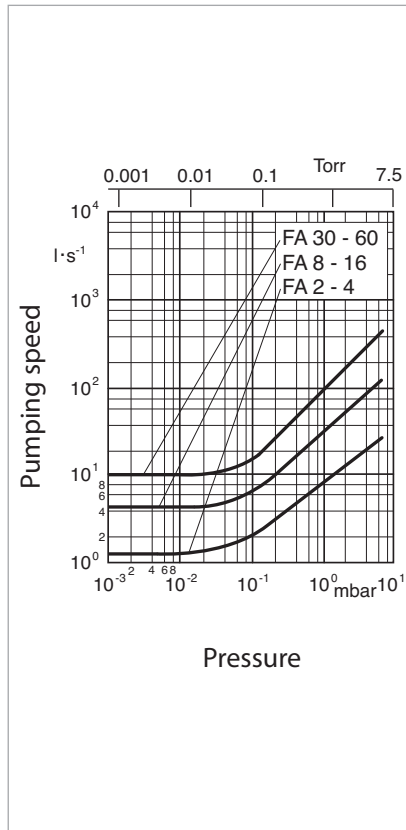

Conductances of fine vacuum adsorption traps as a function of the intake pressure of the TRIVAC

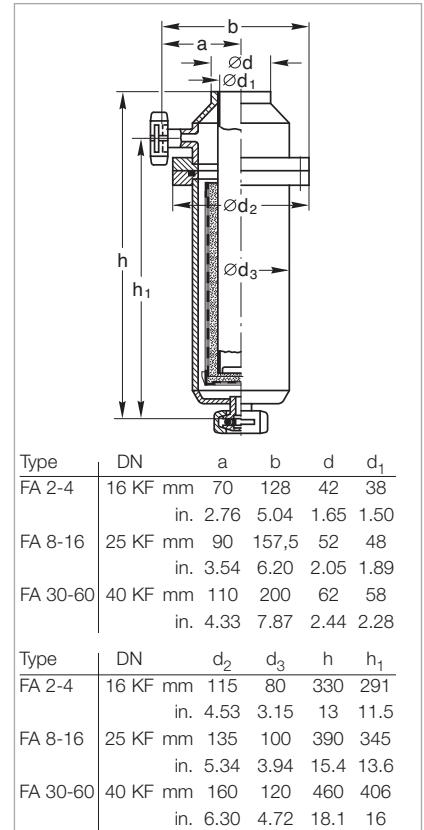

Dimensional drawing for the FA fine vacuum adsorption trap

Technical Data

FA 2-4 FA 8-16 FA 30-60

Connection to pump	TRIVAC	NT 5/10 ¹⁾ D 2,5 E D 4/8 B	NT 16/25	D 40/65 B/BCS
Zeolite filling, approx.	kg (lbs)	0.3 (0.7)	0.7 (1.5)	1.25 (2.8)
Conductance below 10 ⁻² mbar (0.075 Torr)	l x s ⁻¹	1	4	9
Power rating of the heating rod at a main voltage of 220 V	W	200	200	300

Ordering Information

FA 2-4 FA 8-16 FA 30-60

Fine vacuum adsorption trap filled with zeolite, without heating rod	Part No. 187 05	Part No. 187 10	Part No. 187 15
Heating rod for adsorption trap	Part No. 854 21	Part No. 854 21	Part No. 854 23
Molecular sieve zeolite 13 X, 1 kg (2.2 lbs)	Part No. 854 20	Part No. 854 20	Part No. 854 20

¹⁾ Reducer and elbow for installation required

Mechanical Oil Filters OF 4-25 and OF 40-65 / Chemical Oil Filters CF 4-25 and CF 40-65



OF 4-25 mechanical oil filter

Since there is a pressure-lubrication system with an oil pump in every TRIVAC B and NT 16/25, it is possible to connect main flow oil filters.

These filters are available either for mechanical filtering (OF types) or combined chemical/mechanical filtering (CF types).

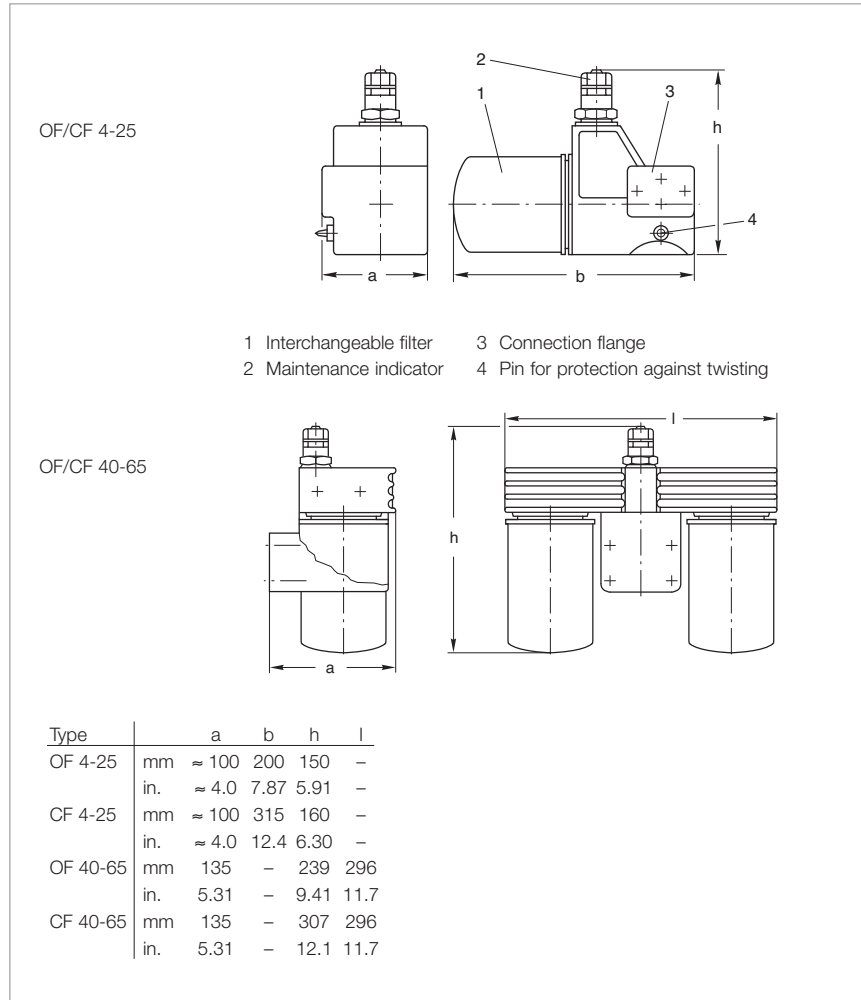

Dimensional drawings for the OF mechanical oil filters and CF chemical oil filters

Advantages to the User

- Main flow oil filter
- Longer service life for the oil depending on the type of application
- Can be installed without problems to the TRIVAC B and NT 16/25
- Hose connections are not required
- Easily interchangeable filters
- Only a small amount of oil needs to be added when changing the filters
- Expansion of the range of applications in case of special requirements

Typical Application

- Same casing for OF and CF types
- Greater reliability by standard maintenance indicator
- Built-in bypass valve
- Owing to the highly effective adsorbent for polar substances, an up to ten-fold adsorption effect is attained over normal bleaching earth (CF)
- Prevents mechanical damage to the pump
- Separation of fine particles from the pump's oil (sizes between 5 and 10 μm (OF))

Technical Data**OF 4-25****CF 4-25****OF 40-65****CF 40-65**

Connection to pump	TRIVAC	NT 16/25 ¹⁾ D 4/8 B, D 16/25 B	NT 16/25 ¹⁾ D 4/8 B, D 16/25 B	D 40/65 B	D 40/65 B
Nominal throughput	l x h ⁻¹	900	900	2000	2000
Separation					
mechanical oil filter	µm	5 to 10	5 to 10	5 to 10	5 to 10
chemical oil filter	µm	to 3	to 3	to 3	to 3
Permissible operating pressure	bar (psig)	2.5 (21.7)	2.5 (21.7)	2.5 (21.7)	2.5 (21.7)
Opening pressure, non-return valve	bar (psid)	0.12 (1.7)	0.12 (1.7)	0.12 (1.7)	0.12 (1.7)
bypass valve	bar (psid)	2.5 ±0.3 (21.7 ±4.3)	2.5 ±0.3 (21.7 ±4.3)	2.5 ±0.3 (21.7 ±4.3)	2.5 ±0.3 (21.7 ±4.3)
Topping up amount during first time installation	l (qt)	1.0 (1.1)	1.0 (1.1)	2.5 (2.6)	2.5 (2.6)
filter exchange	l (qt)	1.0 (1.1)	1.0 (1.1)	2.0 (2.1)	2.0 (2.1)
Weight, ready for operation, dry	kg (lbs)	4.0 (8.8)	4.0 (8.8)	10.0 (22.1)	10.0 (22.1)

Ordering Information**OF 4-25****CF 4-25****OF 40-65****CF 40-65**

Mechanical oil filter	Part No. 101 91	-	Part No. 101 92	-
Chemical oil filter	-	Part No. 101 96	-	Part No. 101 97
WF 4-25 interchangeable filter, paper, 0.5 l (0.5 qt)	Part No. 189 91	-	-	-
WF 40-65 interchangeable filter, paper 0.75 l (0.8 qt)	-	-	Part No. 189 92 (2x)	Part No. 189 92 (2x)
WF Alu 4-65 interchangeable filter, paper and Al ₂ O ₃ , 1 l (1 qt)	-	Part No. 189 96	-	Part No. 189 96 (2x)

¹⁾ An adapter 140 299 is required

Chemical Filters with Safety Isolation Valve CFS 16-25 and CFS 40-65



CFS 40-65

The CFS chemical filters with safety isolation valve are main flow oil filters for the TRIVAC B, NT 16/25 and BCS pumps.

The CFS is part of the TRIVAC SYSTEM.

Advantages to the User

- The CFS is included in the main lubricant flow
- Rapid filter exchange – the pump may continue to operate while changing the filters
- Visual indication of the filter's condition through a maintenance indicator
- Aluminum component with isolation valve for one or two interchangeable filters
- All aluminium parts are surface protected
- May be operated with different interchangeable filters
- Over-pressure relief valve in the interchangeable filters
- Prepared for connection of a differential pressure switch and an oil pressure switch
- May also be used on the TRIVAC B and NT 16/25 pumps

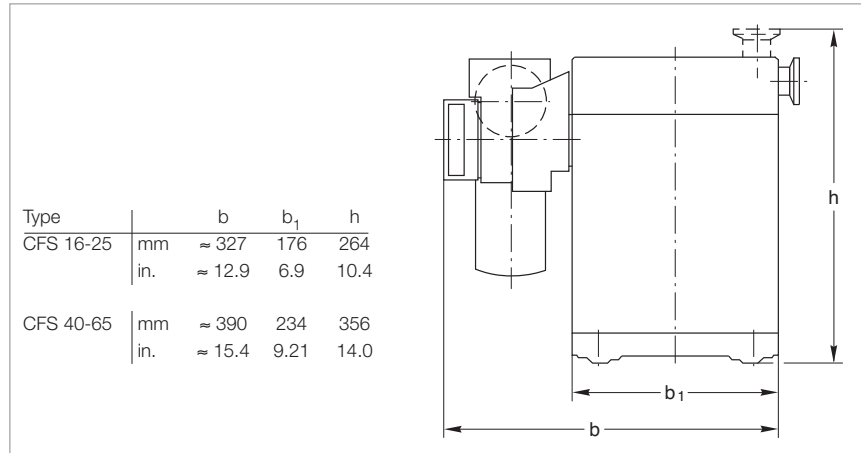

Dimensional drawing for the CFS (mounted on a TRIVAC BCS)

Technical Information

The CFS is cleaned in the factory to such an extent, that it may be operated either with mineral oil (e.g. N 62 or HE-200) or perfluoropolyther (PFPE e.g. NC 1/14 or HE-1600).

Supplied Equipment

All gaskets and mounting parts required for installation.

Aluminium particle filters (WF Alu-Part) sealed for shipping are included separately.

Technical Data

		CFS 16-25	CFS 40-65
Connection to pump	TRIVAC	NT 16/25 ¹⁾	D 40/65 B/BCS (-PFPE)
		D 16/25 B/BCS (-PFPE)	D 40/65 B/BCS (-PFPE)
Nominal throughput	l x h ⁻¹	900	2000
Permissible operating pressure	bar (psig)	2.5 (21.7)	2.5 (21.7)
Opening pressure	Non-return valve	bar (psid)	2.5 (21.7)
	Bypass valve	bar (psid)	2.5 ± 0.3 (21.7 ± 4.3)
Filter medium		Al ₂ O ₃	Al ₂ O ₃
Lubricant filling when using WF Alu-Part	l (qt)	1.4 (1.5)	3.3 (3.5)
Weight, ready for operation, dry	kg (lbs)	7.0 (15.4)	15.5 (34.1)

Ordering Information

	CFS 16-25	CFS 40-65
Chemical filter with safety isolation valve	Part No. 101 76	Part No. 101 77
WF Alu-Part combination filter, paper and Al ₂ O ₃ , 1.6 l (1.7 qt)	Part No. 189 99	Part No. 189 99 (2x)
WF particle filter, paper, 1.6 l (1.7 qt)	Part No. 200 09 804	Part No. 200 09 804 (2x)
WFG particle filter, paper with support mesh, 1 l (1 qt)	Part No. 189 90	Part No. 189 90 (2x)

¹⁾ An adapter 140 299 is required

Inert Gas System

IGS 16-25 and IGS 40-65



IGS

This accessory, which is controlled via solenoid valves, permits the controlled admission of special gases into the TRIVAC BCS.

The IGS is part of the TRIVAC SYSTEM.

Advantages to the User

- Ready for connection to an inert gas supply
- Solenoid valve for reduced gas ballast
- Solenoid valve for purging the oil box
- Float throughput gauge with throttling valve adjustable from 200 to 700 l x h⁻¹
- The flowing quantity can be read directly
- System protection by a non-return valve (requires a reservoir pressure of at least 3 bar (29 psi, gauge)) – this reliably prevents the reservoir vessel from being evacuated
- Connects directly on to the TRIVAC BCS

Typical Applications

- Reduction of the contamination levels in the lubricant
- Reduction in the dwell time of volatile substances within the pump

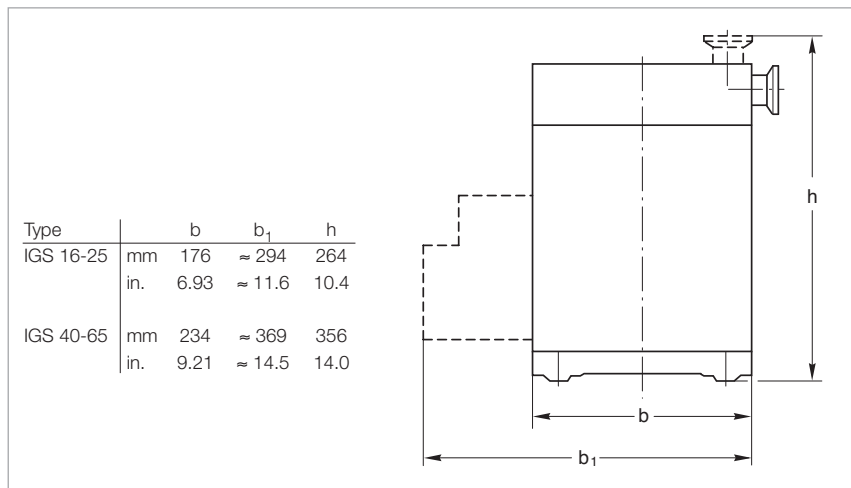

Dimensional drawing for the IGS (mounted on a TRIVAC BCS)

Technical Information

The amount of inert gas ballast is restricted by a nozzle to 200 l x h⁻¹. Larger quantities are used for purging.

Supplied Equipment

Solenoid valves with connection cables and plugs, the required connecting pieces, mounting screws and cover panel.

Technical Data

	TRIVAC	IGS 16-25	IGS 40-65
Connection to pump	TRIVAC	D 16/25 BCS (-PFPE)	D 40/65 BCS (-PFPE)
Min. amount of admitted gas at a reservoir pressure of 3.0 bar (29 psig)	l x h ⁻¹	200	200
Max. amount of admitted gas at a reservoir pressure of 6.0 bar (72.5 psig)	l x h ⁻¹	1450	1450
Supply voltage for the solenoid valves	V DC	24	24
Power consumption	W	10	10
Weight	kg (lbs)	1.0 (2.2)	1.4 (3.1)
Connection thread	G (BPS)	1/8"	1/8"

Ordering Information

	IGS 16-25	IGS 40-65
Inert gas system	Part No. 161 76	Part No. 161 77

Limit Switch System

LSS 16-25 and LSS 40-65



LSS

This accessory consists of a package of limit switches. It is used to monitor system functions.

The LSS is part of the TRIVAC SYSTEM.

The package of limit switches includes:

- Differential pressure switch to monitor the CFS
- Oil pressure switch to monitor the operating pressure
- Flow switch to monitor the inert gas flow
- Pressure switch to monitor the pressure in the oil box of the pump
- Connection cable and plug for the temperature switch used for temperature monitoring
- Float switch with housing to monitor the oil level

Advantages to the User

- Errors are indicated well in advance so that it will in most cases be possible to complete the process for the running batch
- The switching action is independent of the optical displays (for optimum reliability)
- The temperature switch is already present in the TRIVAC BCS

Type		l	s
LSS 16-25	mm	506 (for D 16 BCS)	55
	in.	19.92 (for D 16 BCS)	2.17
LSS 40-65	mm	567 (for D 25 BCS)	55
	in.	22.32 (for D 25 BCS)	2.17
LSS 40-65	mm	716 (for D 40 BCS)	51
	in.	28.19 (for D 40 BCS)	2.01
LSS 40-65	mm	794 (for D 65 BCS)	51
	in.	31.26 (for D 65 BCS)	2.01

Dimensional drawing for the LSS (mounted on a TRIVAC BCS)

Typical Application

- Changing the status in case operating conditions arise which are not permissible

Supplied Equipment

Fully wired-up switches with plugs as well as all required gaskets and mounting parts.

Technical Data

		LSS 16-25	LSS 40-65
Connection to pump	TRIVAC	D 16/25 BCS (-PFPE)	D 40/65 BCS (-PFPE)
Operating voltage	V DC	24	24
Switching capacity	W / A	10.0 / 0.4	10.0 / 0.4
Type of protection	IP	54	54
Weight, approx.	kg (lbs)	2.5 (5.5)	2.5 (5.5)

Ordering Information

	LSS 16-25	LSS 40-65
Limit switch system	Part No. 161 06	Part No. 161 07

Roots Pump Adaptor

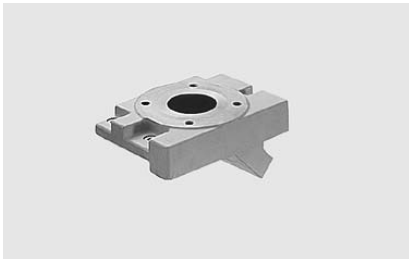

Roots pump adaptor

The Roots pump adaptor allows the direct installation of a Roots pump on a TRIVAC D 40/65 B/BCS.

Advantages to the User

- Compact and space-saving
- Short and direct connection between the pumps
- Minimal conductance loss
- Easy installation

Typical Application

- Simple assembly of a small pump system

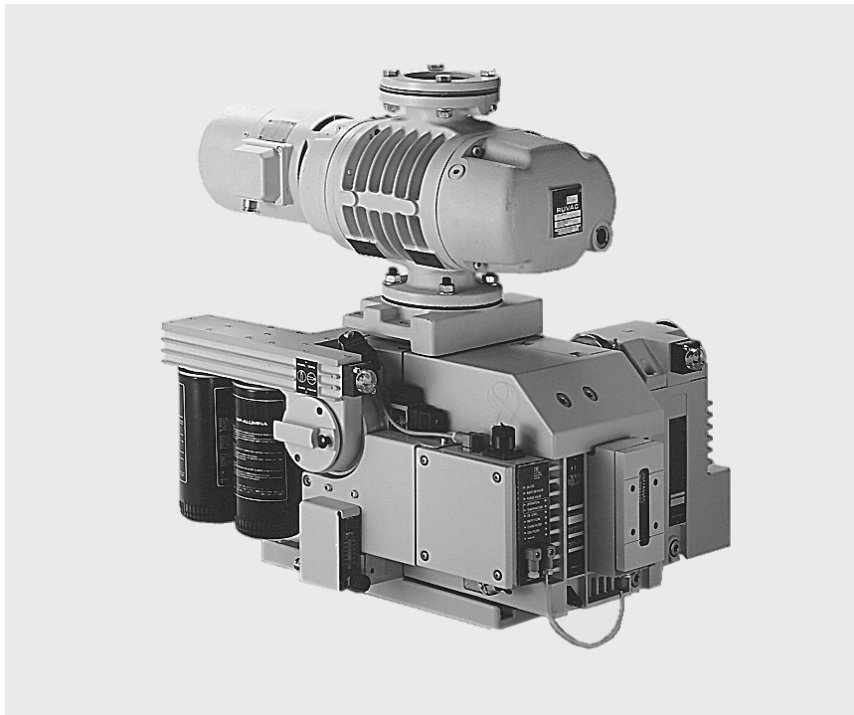

Pump system consisting of a TRIVAC D 65 BCS and a RUVAC WS 251

Technical Data

Connection to pump	TRIVAC	D 40/65 B/BCS (-PFPE) and RUVAC WA/WAU/WS/WSU 251
Weight, approx.	kg (lbs)	11.5 (25.4)

Roots Pump Adaptor

Ordering Information

Roots pump adaptor	Part No. 168 30
--------------------	------------------------

Roots Pump Adaptor

Only available for purchase in North and South America

OF1000 Oil Filtering System

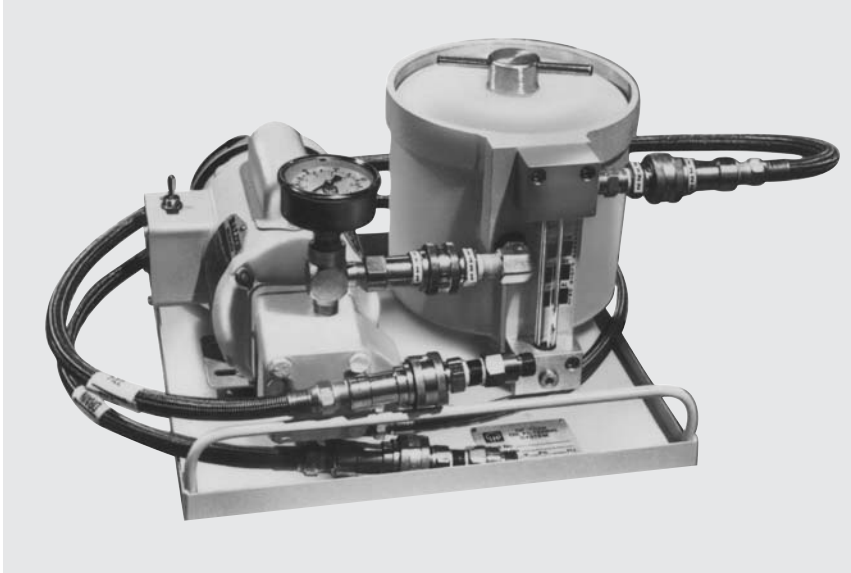

OF1000 Oil Filtering System

Advantages to the User

- Choice of single- and dual-canister models for standard or chemically severe applications
- Compact design
- Reliable operation
- Choice of four filtering elements
- Dripless quick disconnects for easy removal and replacement of filter elements
- Recessed lid and oil level – no oil spillage
- Conductive Teflon hoses for static charge dissipation – no oil leakage due to static burning
- Integral gear pump with built-in bypass
- Fluid sight glass and flow monitor
- Pressure gauge
- Small precharge fluid volume
- Single phase 50/60 Hz motors standard

Applications

Standard series models are widely used in silicon production processes, including LPCVD, low-pressure epitaxy, ion implantation, reactive ion etching and several plasma processes. Such processes employ a variety of gases which can react with pump fluid, resulting in the formation of sludge, particulates and acids. The standard OF1000 model has proven effective at extending maintenance intervals in such applications.

Similarly, chemically resistant OF1000C models have proven successful in aluminum etching and other processes where boron trichloride and other highly toxic gases are employed. The canister, gear pump, fittings and quick disconnects of the corrosive-service model have been specially treated with a fluorocarbon material that substantially increases the life of these components.

OF1000 oil filtering systems are designed to remove acids and particulates from the lubricating fluid used in Oerlikon Leybold Vacuum mechanical vacuum pumps. The systems are located externally from the vacuum pump, and utilize their own integral gear pump in conjunction with a bypass to

continuously recycle fluid through a filtering medium; the medium is housed in an element/canister assembly which additionally serves to absorb heat, and thus reduce the operating temperature of the vacuum pump.

OF1000 systems are available in both single- and dual-canister designs. Both types are highly compact and reliable, and can be supplied in models for standard or chemically severe applications. Single-canister OF1000 models are distinguished by their smaller footprint while dual-canister configurations afford the advantages of multi-media filtration and increased oil capacity. Dual-canister models are designed for series flow through two side-by-side mounted canisters, and thus can be used to filter oil through two different media on the same pass or for double filtration through elements containing the same medium. The models also enable the vacuum pump to operate at somewhat lower temperatures, while providing it with a larger supply of clean, filtered oil.

All OF1000 models are supplied with a choice of four filtering elements. The Fullers Earth element provides high capacity for standard acids and

can be used to trap particulates down to 10 micron in size. Hydrophilic, activated alumina and fiberglass particulate elements are also available. The Hydrophilic element is particularly effective for hydrolyzed acids, and can also be used to trap particles as small as 1 micron. The Activated Alumina element provides 10 micron particulate retention and is extremely effective for Lewis acids and polar compounds. The fiberglass element is suitable for particulate removal down to 10 micron.

The element/canister assembly of OF1000 systems is easy to install, extremely easy to remove and replace. The recessed lid and oil level of the assembly safeguards against the possibility of spillage. Dripless quick disconnects are also provided for easy canister removal and safer disposal of the filtering element and oil.

OF1000 systems also come equipped with flexible Teflon hoses designed to resist dielectric breakdown. The systems thus ward against the possibility of oil leaks due to pinholing or static burning of the hose.

Technical Data**Single-Canister
Systems****Dual-Canister
Systems**

Gear pump motor		1/6 HP, 115/208/220V, single phase, 50/60Hz, wired for 115V, with on/off switch ¹⁾	1/6 HP, 115/208/220V, single phase, 50/60Hz, wired for 115V, with on/off switch ¹⁾
Gear pump		0.7 gpm @ 1800 RPM	0.7 gpm @ 1800 RPM
Pressure gauge		0 to 100 psig (0 to 70 kPa)	0 to 100 psig (0 to 70 kPa)
Pump fluid capacity		15 lb perfluorinated polyether or 3.75 qt hydrocarbon oil	29 lb perfluorinated polyether or 7.25 qt hydrocarbon oil
Flexible hoses		3/8 in. I.D. teflon/carbon black with stainless steel braid – 4 ft lengths ²⁾	3/8 in. I.D. teflon/carbon black with stainless steel braid – 4 ft lengths ²⁾
Dimensions	in. (mm)	16 x 14 x 11 (406 x 356 x 279)	23 x 14 x 11 (585 x 356 x 279)
Flow arrangement		–	series ³⁾
Weight (Dry)	lbs (kg)	45 (20.4)	60 (27.2)

¹⁾ Hazardous duty models and special voltages also available

²⁾ Optional 6, 10 and 15 feet hoses available

³⁾ Optional parallel flow arrangement also available

Ordering Information**Single-Canister Systems****Dual-Canister Systems**

Oil filtering system OF1000 less filtering element and oil	Part No. 898 550	Part No. 898 552
OF1000 prepared for PFPE, less filtering element and oil	Part No. 898 551	Part No. 898 553
OF1000C chemically severe service, prepared for PFPE fluid	Part No. 898 561	Part No. 898 554

Accessories

Spare filter canister assembly with quick disconnect	Part No. 898 555	Part No. 898 557 (front), Part No. 898 555 (rear)
prepared for PFPE, with quick disconnect	Part No. 898 556	Part No. 898 558 (front), Part No. 898 556 (rear)
chemically severe service	Part No. 898 566	Part No. 898 559 (front), Part No. 898 566 (rear)

Filtering Elements

Aluminum Oxide high capacity for reagent grade HCl; removes Lewis acids and polar compounds; 10 micron particulate retention	Part No. 898 504	Part No. 898 504
Fullers Earth acid and particulate filter with capacity of 34 ml reagent grade HCl; 10 micron particulate retention	Part No. 898 505	Part No. 898 505
Hydrophilic water and HCl acid absorbing capabilities; 1 micron particulate retention	Part No. 898 506	Part No. 898 506
Particulate fiberglass element with 10 micron particulate retention	Part No. 898 507	Part No. 898 507

Only available for purchase in North and South America

RST Refillable Traps



RST refillable trap

The RST traps are made from 304 stainless steel, and when specified with stainless steel filtration media, are fully suited for corrosive applications. The media is inserted directly into the trap. This ensures direct contact with the trap walls. There is no oil path between the trap wall and the retainer gasket to reduce trap effectiveness.

Advantages to the User

- Refillable
- Two filtration media
- Easy to clean
- Easy to recharge
- KF flanges

Applications

Foreline traps are utilized whenever long-term effects of mechanical pump oil back migration into the pumped chamber or higher vacuum (oil diffusion) pump may be undesirable. Copper wool for standard applications and stainless steel wool for corrosive applications are available.

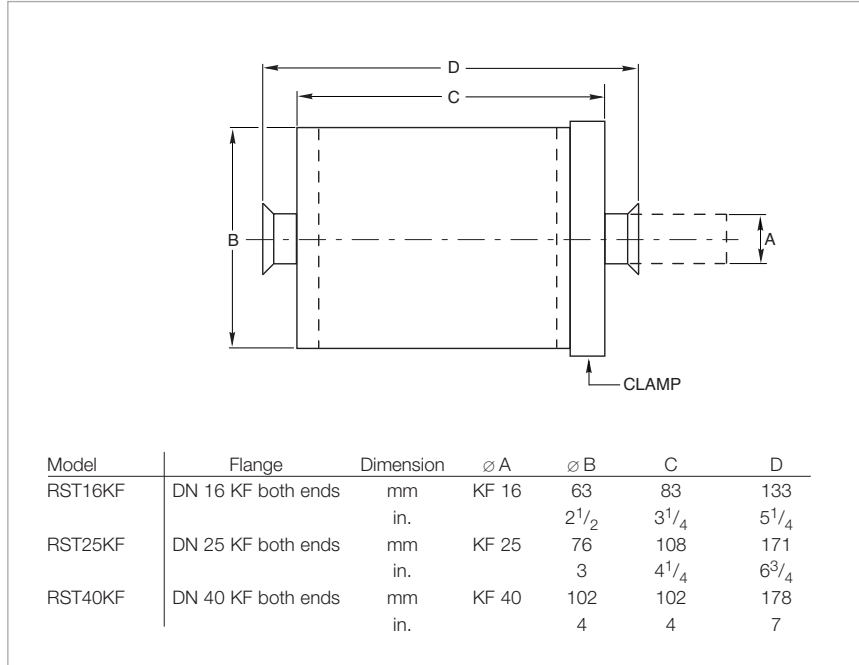

Dimensional drawing for the RST

Technical Data

RST16KF RST25KF RST40KF

Connection to pump	TRIVAC	NT 5/10 ¹⁾	NT 16/25	D 40/65 B/BCS
		D 4/8 B/BCS	D 16/25 B/BCS	

Ordering Information

RST16KF RST25KF RST40KF

RST16KF 1.9 lb (0.9 kg)	Part No. 99 171 135	-	-
RST25KF 2.6 lb (1.2 kg)	-	Part No. 99 171 136	-
RST40KF 4.1 lb (1.9 kg)	-	-	Part No. 99 171 137
Filtering media	Part No. 99 171 141	Part No. 99 171 141	Part No. 99 171 141
	Stainless steel	RF copper	RF copper
	Part No. 99 171 145	Part No. 99 171 146	Part No. 99 171 147
BUNA-N gasket	Part No. 725 80 005	Part No. 725 80 006	Part No. 725 80 007

¹⁾ Reducer and elbow for installation required

Only available for purchase in North and South America

SE Smoke Eliminator



SE smoke eliminator

The Oerlikon Leybold Vacuum SE smoke eliminator can be utilized on all TRIVAC B and NT rotary vane pumps where pump fluid loss at the exhaust port must be eliminated. These filters consist of a replaceable two-stage coalescing element mounted in a steel housing. For maintenance purposes, the top of the housing can be removed by loosening a single bolt. The filter assembly attaches to the exhaust port of the TRIVAC pump by means of a KF flange. Since three models are available, an SE smoke eliminator is available for each TRIVAC pump model.

Advantages to the User

- Two stage design
- Three sizes for all TRIVAC B and NT models
- KF flanges

Applications

When any oil sealed mechanical vacuum pump is used to pump a fixed volume from atmospheric pressure to some lower pressure or when a dynamic gas flow from a process stream is pumped, some mechanical pump fluid loss will occur at the exhaust of the pump. The more often a fixed volume is cycled from atmospheric pressure to a lower pressure or the longer a pump operates at a relatively high inlet pressure in a dynamic flow condition, the greater will be the fluid loss at the exhaust port of the pump.

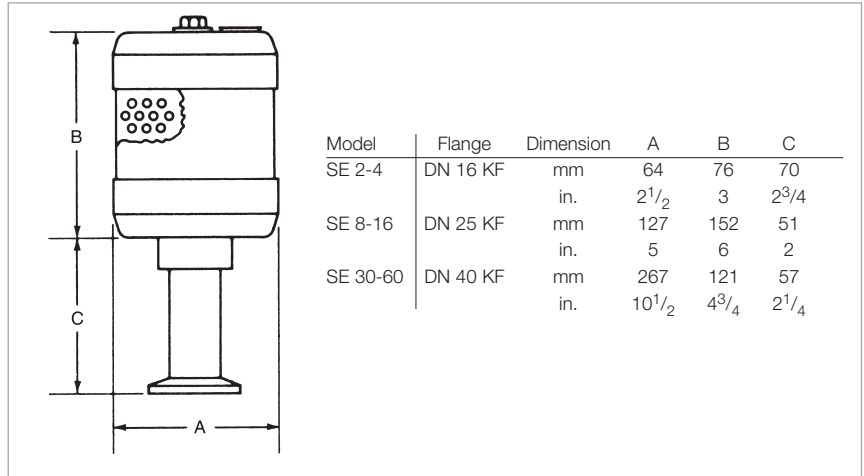

Dimensional drawing for the SE

Technical Data

SE 2-4

SE 8-16

SE 30-60

Connection to pump	TRIVAC	D 4/8 B NT 5/10	D 16/25 B NT 16/25	D 40/65 B
--------------------	--------	--------------------	-----------------------	-----------

Ordering Information

SE 2-4

SE 8-16

SE 30-60

Smoke eliminator	Part No. 99 171 125	Part No. 99 171 126	Part No. 99 171 127
Replacement element RE 2-4	Part No. 99 171 128	-	-
RE 8-16	-	Part No. 99 171 129	-
RE 30-60	-	-	Part No. 99 171 130

By utilizing a coalescing exhaust filter for these applications, the fluid and exhaust gases are separated, and in the case of the SE smoke eliminator, the coalesced fluid is allowed to drain back into the pump fluid reservoir. Annoying oil fog to the atmosphere is thus eliminated.

Eventually, after about a year's normal operation, the coalescing element will become totally saturated and oil fog will be apparent when high inlet pressures are prevailing. The low cost coalescing element can be easily replaced.

Note: For applications where toxic, corrosive, radioactive or precious gases are pumped, we highly recommend the use of our AF coalescing exhaust filters instead of the SE smoke eliminator. The AF is an in-line type coalescing filter and much more suitable for these applications.

Only available for purchase in North and South America

Compact Oil Mist Exhaust Filters



Compact oil mist exhaust filter

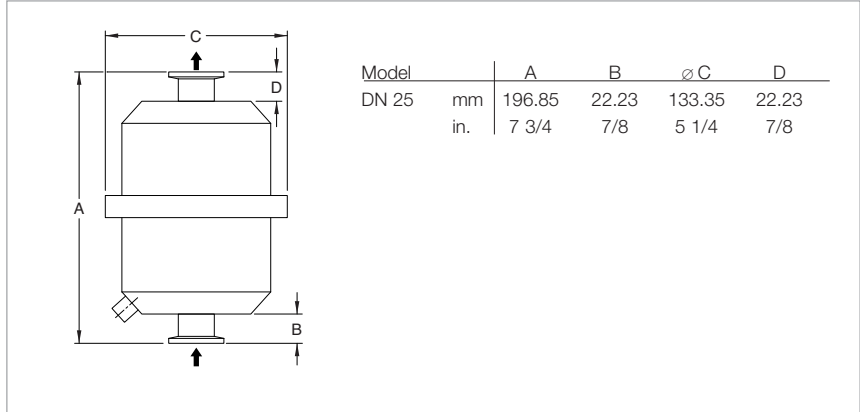

Dimensional drawing for the compact oil mist exhaust filter

Applications and Equipment

- Rotary vane pumps
- Vacuum furnaces, ovens and degassing
- Refrigeration and air condition
- Vacuum freeze drying
- Vacuum metallizing
- Vacuum coating
- Laboratory furnaces, test stands
- Autoclaving, sterilization
- Leak detection

Features and Specifications

- Minimum 99.97% D.O.P. on 3 micron particles
- Captures oil fog, mist or smoke from exhaust of oil lubricated vacuum pumps
- Compact, low profile design
- Stainless steel housing and internals
- Pleated filter element provides increased surface area for low back pressure
- Back pressure valve designed to release element at 7.35 PSI (0.5 bar) differential for pump safety
- 1/8" NPT oil drain
- Easy release V-band clamp
- Seamless drawn housings - no welds to rust or vibrate apart
- Easy field maintenance
- Operating temperature: 40 °F (4 °C) to 220 °F (104 °C)

Technical Data

Compact Oil Mist Exhaust Filter

Connection to pump	TRIVAC	D16/25B and NT 16/25
ISO inlet and outlet		DN 25
Nominal vacuum pump rating	scfm (m ³ /h)	20 (34)
Element rating	scfm (m ³ /h)	20 (34)
Weight, approx.	kg (lbs)	1 (2.2)

Ordering Information

Compact Oil Mist Exhaust Filter

Compact oil mist exhaust filter	Part No. 721 87 113
Replacement filter insert filter	Part No. 721 87 099

General Accessories

Flange Components, Valves

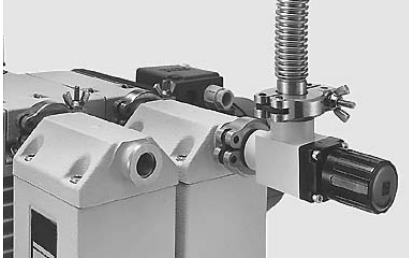

Our range of flange components and valves is described in detail in Product Sections C13 and C14.

Given in the following are only some components which you might find particularly useful when planning your system.

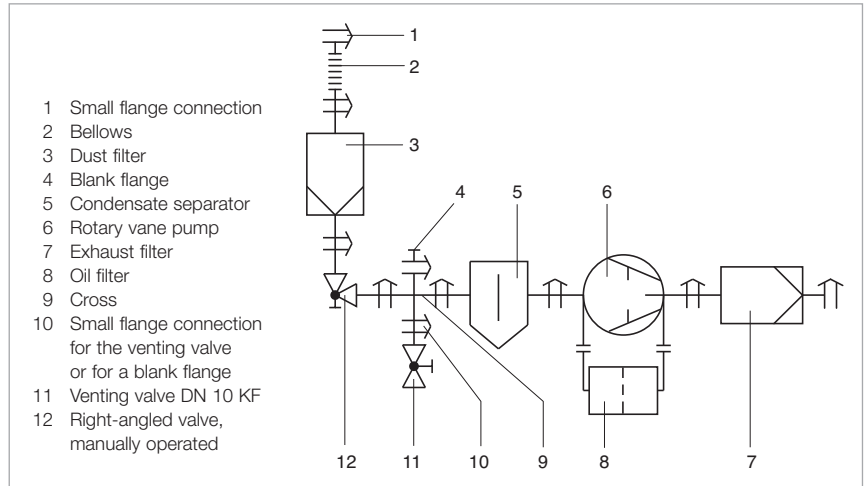

Example of connecting a pump with accessories

Isolation Valve

- The pump is allowed to warm up with the intake line isolated
- The pump may continue to operate in the energy-saving and environmentally compatible ultimate pressure mode when the vacuum chamber is vented briefly
- The pump may be left on after completion of the process so as to regenerate the oil

Branch (Cross)

- Installing a cross in the intake line permits the connection of a vacuum gauge and a venting valve

Flange Connections

Each flange connection requires one each centering and clamping ring.

Ordering Information

DN 16 KF DN 25 KF DN 40 KF

Small flange connection			
Clamping ring			
Centering ring, aluminum/CR	Part No. 183 41	Part No. 183 42	Part No. 183 43
Centering ring, stainless steel/ FPM (FKM)	Part No. 183 26	Part No. 183 27	Part No. 183 28
	Part No. 883 46	Part No. 883 47	Part No. 883 48
Bellows	Part No. 872 41	Part No. 872 43	Part No. 872 45
Right-angled valve, manually operated			
Aluminum casing	Part No. 215 375	Part No. 215 376	Part No. 215 377
Stainless steel casing	Part No. 215 383	Part No. 215 385	Part No. 215 386
Blank flange for (reducing) cross			
Aluminium	Part No. 184 46	Part No. 184 41	Part No. 184 41
Stainless steel	Part No. 884 36	Part No. 884 41	Part No. 884 41
Reducing cross (to DN 10 KF)			
Aluminium	-	Part No. 184 17	Part No. 184 19
Stainless steel	-	Part No. 884 92	Part No. 884 94
Cross DN 16 KF			
Aluminium	Part No. 184 71	-	-
Stainless steel	Part No. 884 85	-	-
Small flange connection for venting valve or blank flange			
Clamping ring	Part No. 183 41	Part No. 183 41	Part No. 183 41
(Adaptor) centering ring, aluminum/NBR	Part No. 183 56	Part No. 183 21	Part No. 183 21
(Adaptor) centering ring, stainless steel/FPM	Part No. 883 56	Part No. 883 21	Part No. 883 21
Venting valve DN 10 KF			
Aluminium	Part No. 173 24	Part No. 173 24	Part No. 173 24
Stainless steel	Part No. 173 37	Part No. 173 37	Part No. 173 37

Vacuum Pump Oils

Lubricating oils for rotary vane vacuum pumps need to fulfil demanding requirements. Their vapor pressure must be low at high temperatures and the water content and water uptake must be minimal. Their viscosity characteristics need to be flat, lubricating properties need to be excellent and resistant against thermal decomposition and increased mechanical stress.

All the vacuum pump oils listed in the following have been subjected in our factory laboratories to very comprehensive tests closely resembling the conditions encountered in practice by the pumps from the TRIVAC series.

Under vacuum engineering conditions, lubricating oils may react very differently compared to what is being expected of them.

In order to ensure the best possible performance of the Oerlikon Leybold Vacuum pumps, the use of vacuum pump oils qualified by Oerlikon Leybold Vacuum is required.

When using not suitably qualified third party oils, the oil change intervals and the performance of the vacuum pump may be reduced. Also unwanted deposits may occur which may even cause severe damage to the vacuum pump.

Our oils are subjected to an involved qualification process with respect to their technical suitability in our vacuum pumps.

Our warranty commitment is dependent on the usage of lubricating oils which are qualified by us.

No liability will be assumed for any kind of damage caused through the usage of types of oil which have not been qualified or which are unsuitable.

In order to adapt the pumps to the different applications of our customers, different types of oil are used in the TRIVAC pumps.

Please note that owing to differing properties not all types of oil may be used in all pumps of the TRIVAC series.

If you can not find the combination of pump and oil you require by way of a Part No., please ask us for a quotation.

Lubricant Types

Mineral Oils

Mineral oils are products distilled and refined from crude oil. These do not consist of precisely defined compounds but rather consist of a complex mixture. The way in which the mineral oil is pre-treated and its composition is decisive as to the applications it will be suited for. Depending on the distribution of the hydrocarbons and the dominance of certain properties, mineral oils are grouped according to paraffin-base, naphthenic and aromatic. For the purpose of attaining especially low ultimate pressures, mineral oils must be selected on the basis of a core fraction.

The thermal and chemical resistance of mineral oils has been found to be adequate in the majority of applications. They offer a high degree of compatibility with elastomers and resistance to hydrolysis.

Synthetic Oils

Synthetic oils are man-made. The group of synthetic oils includes liquids differing widely as to their chemical structure and composition. Correspondingly their physical and chemical properties differ considerably. Synthetic oils are used in those cases where special properties of the oil are required which can not be fulfilled by mineral oils.

The oils given in the following belong to the group of synthetic oils:

Polyalphaolefin (PAO) Oils

Polyalphaolefin oils are synthetic hydrocarbons which are paraffin like, but have a uniform structure. Thermal and chemical resistance is better compared to mineral oils. Elastomer compatibility and resistance against hydrolysis are comparable to mineral oils.

Ester oils

Ester oils are organic compounds which excel especially through their high thermal resistance to cracking compared to mineral oils. Chemical resistance is generally quite good, but will depend on the type of ester oil. Elastomer compatibility and resistance against hydrolysis are not so good compared to mineral oils.

Perfluorinated polyether (PFPE)

These are oils which are only composed of carbon (C), fluorine (F) and oxygen atoms (O). The existing C-O and C-F bonds are highly stable. For this reason PFPE oils are practically inert against all chemical and oxidising influences.

Perfluorinated polyethers will not polymerise under the influence of high energy radiation.

PFPE is non-flammable. Oerlikon Leybold Vacuum NC 1/14 has the approval of BAM (Federal Institute for Materials Research and Testing) for pumping of pure oxygen.

Perfluorinated polyethers are used when pumping strongly reactive substances like oxygen (O₂), fluorine (F₂) and uranium hexafluoride (UF₆). Regarding Lewis acids (for example, boron trifluoride (BF₃), aluminum trichloride (AlCl₃)) they are not completely inert. Here reactions may take place at temperatures over 100 °C (212 °F).

Perfluorinated polyethers are thermally highly stable. Thermal decomposition may only take place at temperatures of over 290 °C (554 °F)

Caution: Perfluorinated polyethers will – when decomposed – release toxic and corrosive gases: hydrogen fluoride (HF), carbonyl difluoride (COF₂). For this reason open fires must be avoided in the workspace where PFPE is being used. Do not smoke in the workspace where PFPE is being used.

Only suitably prepared pumps must be used in connection with perfluorinated polyethers, since it is essential that the pump be free of hydrocarbons. Changing from one basic type of oil to PFPE must be left exclusively to authorised Service Centers. The pumps will have to be fully disassembled and carefully cleaned. Gaskets and filters will have to be exchanged and suitable greases will have to be used.

Safety data sheets are available to professional users from:

E.mail “documentation.vacuum@oerlikon.com” or Internet “www.oerlikon.com/leyboldvacuum”.

Oil Recommendations for Various Areas of Application

Application Data

N 62

White Oil NC 2

Type of oil	Paraffin-base mineral oil, core fraction, free of additives	Medicinal, high purity white oil, paraffin-base, core fraction, free of additives, sulphur and aromatic compounds
Examples of areas of application and process media	Standard oil for Oerlikon Leybold Vacuum Germany For pumping air, chemically inert permanent gases (noble gases, for example), water vapor, solvent vapors in the case of laboratory pumps operated with cold traps	For pumping small quantities of chemically reactive substances like halogens (for example, hydrogen chloride HCl, hydrogen bromide HBr), halogenated hydrocarbons (for example, bromomethane CH ₃ Br, trichloromethane CHCl ₃), Lewis acids (for example, aluminum chloride AlCl ₃ , titanium tetrachloride TiCl ₄), acetic acid CH ₃ COOH
Remarks	The ultimate pressures stated in our catalogs are based on operation of the pump with N62 (except for the DOT and PFPE pumps) Service life may be extended through the use of an oil filter	When pumping the aforementioned process media, humidity must be avoided Service life may be extended through the use of an oil filter
Elastomer compatibility FPM (Viton) NBR (Perbunan) ¹⁾ EPDM	Suited Conditionally suited Not suited	Suited Conditionally suited Not suited

Technical Data

N 62

White Oil NC 2

Viscosity at 40 °C (104 °F) at 100 °C (212 °F)	mm ² /s (= cSt) mm ² /s (= cSt)	90 10	60 8
Flash point	°C (°F)	> 255 (> 491)	> 240 (> 464)
Vapor pressure at 20 °C (68 °F) at 100 °C (212 °F)	mbar (Torr) mbar (Torr)	< 1 x 10 ⁻⁵ (< 8 x 10 ⁻⁶) < 3 x 10 ⁻³ (< 2 x 10 ⁻³)	< 1 x 10 ⁻⁵ (< 8 x 10 ⁻⁶) 5 x 10 ⁻³ (< 4 x 10 ⁻³)
Density at 15 °C (59 °F)	g/ml	0.88 ²⁾	0.86
Pour point	°C (°F)	< -9 (< +16)	< -12 (< +10)
Middle molecular weight	g/mol	550	480

Ordering Information

N 62

White Oil NC 2

1 liter (1.1 qt)	Part No. 177 01	-
5 liters (5.3 qt)	Part No. 177 02	Part No. 177 29
20 liters (21.1 qt)	Part No. 177 03	Part No. 177 27
180 kg (397.4 lbs) ((200 l))	Part No. 177 05	-

Please note that the technical data stated are only typical data. Slight variations from batch to batch must be expected.

The technical data stated here can not be taken as assured properties

¹⁾ Resistance to decomposing is very much dependent on the share of acrylonitrile in the NBR

²⁾ at 20 °C (68 °F)

Application Data**SHC 224****ANDEROL 555**

Type of oil	Polyalphaolefin PAO	Diester oil
Examples of areas of application and process media	Cold starting at low temperatures is possible. Pumping of chemically inert permanent gases (for example, noble gases) water vapor in small quantities, refrigerants R 717 (ammonia NH ₃)	Used at elevated temperatures, pumping of air, chemically inert permanent gases (noble gases, for example), carbon dioxide CO ₂ , carbon monoxide CO, aliphatic compounds (for example methane CH ₄ , propane C ₃ H ₈ , ethylene C ₂ H ₄), organic solvent vapors
Remarks	Service life may be extended through the use of an oil filter	Do not pump any inorganic acids (HCl, HF, for example), no free halogens (Cl ₂ , F ₂ , for example) or alkaline media (NH ₃ , for example)
Elastomer compatibility FPM (Viton) NBR (Perbunan) ¹⁾ EPDM	Suited Conditionally suited Not suited	Suited Conditionally suited Not suited

Technical Data**SHC 224****ANDEROL 555**

Viscosity			
at 40 °C (104 °F)	mm ² /s (= cSt)	29	94
at 100 °C (212 °F)	mm ² /s (= cSt)	5.6	9
Flash point	°C (°F)	230 (446)	250 (482)
Vapor pressure			
at 20 °C (68 °F)	mbar (Torr)	1 x 10 ⁻⁵ (< 0.75 x 10 ⁻⁵)	7 x 10 ⁻⁵ (< 5 x 10 ⁻⁵)
at 100 °C (212 °F)	mbar (Torr)	8 x 10 ⁻³ (< 6 x 10 ⁻³)	1.5 x 10 ⁻³ (< 1 x 10 ⁻³)
Density at 15 °C (59 °F)	g/ml	0.83	0.96
Pour point	°C (°F)	< -55 (< -67)	-42 (< -44)
Middle molecular weight	g/mol	476	530

Ordering Information**SHC 224****ANDEROL 555**

1 liter (1.1 qt)	Part No. 200 28 181	Part No. 200 10 272
5 liters (5.3 qt)	-	Part No. 200 10 891
20 liters (21.1 qt)	-	Part No. 200 00 193

Please note that the technical data stated are only typical data. Slight variations from batch to batch must be expected.

The technical data stated here can not be taken as assured properties

¹⁾ Resistance to decomposing is very much dependent on the share of acrylonitrile in the NBR

Application Data**ANDEROL RCF-E68N****NC 10**

Type of oil	Polycarboxylic acid ester	Alkyl sulphonic acid ester
Examples of areas of application and process media	Cooling and air-conditioning applications. For refrigerants (for example halocarbon, R134a), HCFC (for example, R123), HFC (for example, R218), CFC (for example, R12) and HC (for example, R600a)	When pumping process media which tend to polymerise (for example, styrene C ₈ H ₈ , butadiene C ₄ H ₆).
Remarks	Use only correspondingly modified pumps Mixing with other types of oil must be absolutely avoided Do not pump any inorganic acids (for example HCl, HF)	Do not use a chemical oil filter Mixing with other types of oil must be absolutely avoided Do not pump any inorganic acids (for example HCl, HF)
Elastomer compatibility FPM (Viton) NBR (Perbunan) ¹⁾ EPDM	Suited Conditionally suited Not suited	Suited Not suited Not suited

Technical Data**ANDEROL RCF-E68N****NC 10**

Viscosity at 40 °C (104 °F)	mm ² /s	68	38
at 100 °C (212 °F)	mm ² /s	10	4
Flash point	°C (°F)	260 (500)	225 (437)
Vapor pressure at 20 °C (68 °F)	mbar (Torr)	No known	1 x 10 ⁻⁴ (8 x 10 ⁻⁵)
at 100 °C (212 °F)	mbar (Torr)	No known	No known
Density at 15 °C (59 °F)	g/ml	1.00	1.05 ²⁾
Pour point	°C (°F)	-54 (-65)	-30 (-22)
Middle molecular weight	g/mol	Not applicable	Not applicable

Ordering Information**ANDEROL RCF-E68N****NC 10**

1 liter (1.1 qt)	Part No. 200 02 754	-
20 liters (21.1 qt)	-	Part No. 177 25

Please note that the technical data stated are only typical data. Slight variations from batch to batch must be expected.

The technical data stated here can not be taken as assured properties

¹⁾ Resistance to decomposing is very much dependent on the share of acrylonitrile in the NBR

²⁾ at 20 °C (68 °F)

Application Data**DOT 4****NC 1/14**

Type of oil	Brake fluid	PFPE
Examples of areas of application and process media	Filling of brake fluid circuits in the car industry	For pumping strong oxidants like oxygen, O ₂ , ozone O ₃ , nitrogen oxides NO _x and sulphur oxides (SO ₂ , SO ₃) as well as reactive substances like halogens (for example fluorine F ₂ , chlorine Cl ₂), hydrogen halides (for example hydrogen chloride HCl, hydrogen bromide HBr), uranium hexafluoride UF ₆ , and conditionally Lewis acids (for example, boron trichloride BCl ₃)
Remarks	Use only in pumps modified for DOT 4 Mixing with other types of oil must be absolutely avoided	Use only in pumps modified for PFPE Mixing with other types of oil must be absolutely avoided Avoid pumping water vapor, especially with corrosive media (see above) The use of a chemical oil filter CF / CFS is strongly recommended
Elastomer compatibility FPM (Viton) NBR (Perbunan) ¹⁾ EPDM	Not suited Not suited Suited	Suited Suited Suited

Technical Data**DOT 4****NC 1/14**

Viscosity at 40 °C (104 °F) at 100 °C (212 °F)	mm ² /s (= cSt) mm ² /s (= cSt)	No known > 2	47 5
Flash point	°C (°F)	> 120 (> 248)	- ²⁾
Vapor pressure at 20 °C (68 °F) at 100 °C (212 °F)	mbar (Torr) mbar (Torr)	1.3 (0.98) No known	3 x 10 ⁻⁷ (2.25 x 10 ⁻⁷) 6 x 10 ⁻⁴ (4.5 x 10 ⁻⁴)
Density at 15 °C (59 °F)	g/ml	1.05	1.89 ³⁾
Pour point	°C (°F)	Not applicable	-40 (-40)
Middle molecular weight	g/mol	Not applicable	2500

Ordering Information**DOT 4****NC 1/14**

1 liter (1.1 qt) ((1.9 kg))	Part No. 200 10 037	Part No. 177 38
-----------------------------	----------------------------	------------------------

Please note that the technical data stated are only typical data. Slight variations from batch to batch must be expected.

The technical data stated here can not be taken as assured properties

¹⁾ Resistance to decomposing is very much dependent on the share of acrylonitrile in the NBR

²⁾ **Caution:** Perfluorinated polyether compounds will, when being decomposed at temperatures over 290 °C (554 °F), release toxic and corrosive gases. For this reason open fires must be avoided in the workspace where PFPE is being used. Do not smoke in the workspace where PFPE is being used

³⁾ at 20 °C (68 °F)

Only available for purchase in North and South America

Application Data

HE-200

HE-1600

Type of oil	Paraffin-base mineral oil, core fraction, free of additives	PFPE
Examples of areas of application and process media	Standard oil for Oerlikon Leybold Vacuum USA For pumping air, chemically inert permanent gases (noble gases, for example), water vapor, solvent vapors in the case of laboratory pumps operated with cold traps	For pumping strong oxidants like oxygen, O ₂ , ozone O ₃ , nitrogen oxides NO _x and sulphur oxides (SO ₂ , SO ₃) as well as reactive substances like halogens (for example fluorine F ₂ , chlorine Cl ₂), hydrogen halides (for example hydrogen chloride HCl, hydrogen bromide HBr), uranium hexafluoride UF ₆ , and conditionally Lewis acids (for example, boron trichloride BCl ₃)
Remarks	The ultimate pressures stated in our catalogs are based on operation of the pump with HE-200 (except for the DOT and PFPE pumps) Service life may be extended through the use of an oil filter	Use only correspondingly modified pumps Mixing with other types of oil must be absolutely avoided The uptake of water vapor must be avoided The use of an oil filter is strongly recommended
Elastomer compatibility FPM (Viton) NBR (Perbunan) ¹⁾ EPDM	Suited Conditionally suited Not suited	Suited Suited Suited

Technical Data

HE-200

HE-1600

Viscosity at 40 °C (104 °F) at 100 °C (212 °F)	mm ² /s (= cSt) mm ² /s (= cSt)	58 9.1	140 ²⁾ 7
Flash point	°C (°F)	224 (435)	– ³⁾
Vapor pressure at 25 °C (77 °F) at 100 °C (212 °F)	mbar (Torr) mbar (Torr)	4.7 x 10 ⁻⁶ (3.5 x 10 ⁻⁶) 3.9 x 10 ⁻⁴ (2.9 x 10 ⁻⁴)	7 x 10 ⁻⁷ (5 x 10 ⁻⁷) ²⁾ 3 x 10 ⁻⁴ (2 x 10 ⁻⁴)
Density at 20 °C (68 °F)	g/ml	0.88	1.86
Pour point	°C (°F)	-10 (14)	-40 (-40)
Molecular weight		480	3000

Ordering Information

HE-200

HE-1600

1 qt (1.1 l)	Part No. 98 198 006	–
1 gal (3.8 l)	Part No. 98 198 007	–
5 gal (18.9 l)	Part No. 98 198 008	–
55 gal (208 l)	Part No. 98 198 010	–
Bottle 2 lb (0.91 kg)	–	Part No. 898 564-1
Bottle 4 lb (1.81 kg)	–	Part No. 898 564-2
Bottle 16 lb (7.25 kg)	–	Part No. 898 564-4

Please note that the technical data stated are only typical data. Slight variations from batch to batch must be expected.

The technical data stated here can not be taken as assured properties

¹⁾ Resistance to decomposing is very much dependent on the share of acrylonitrile in the NBR

²⁾ at 20 °C (68 °F)

³⁾ Caution: Perfluorinated polyether compounds will, when being decomposed at temperatures over 290 °C (554 °F), release toxic and corrosive gases.

For this reason open fires must be avoided in the workspace where PFPE is being used. Do not smoke in the workspace where PFPE is being used

Services

On-site Replacement of the Dynamic Seals (with N 62) ¹⁾

The on-site replacement of the dynamic seals includes the following:

Partial disassembly of the pump, replacement of the complete shaft seal, mounting of the pump including new gaskets and standard oil N 62, electrical safety test, test run including check of the attained ultimate pressure levels

Ordering Information

On-site Replacement of the Dynamic Seals (with N 62) ¹⁾

Ordering Information	On-site Replacement of the Dynamic Seals (with N 62) ¹⁾
For pump	
TRIVAC S/D 4 B	Part No. AS 1130 F
TRIVAC S/D 8 B	Part No. AS 1130 F
TRIVAC S/D 16/25 B	Part No. AS 1129 F
TRIVAC S/D 40/65 B	Part No. AS 1128 F
TRIVAC S/D 40/65 BCS	Part No. AS 1137 F

Small On-site Maintenance (with N 62) ¹⁾

The small on-site maintenance includes the following:

Oil change (standard N 62), filter replacement, visual inspection of the subassemblies, cleaning of the pump module and the oil box, electrical safety test, test run including check of the attained ultimate pressure levels

Ordering Information

On-site Maintenance (with N 62) ¹⁾

Ordering Information	On-site Maintenance (with N 62) ¹⁾
For pump	
TRIVAC S/D 4 B	Part No. AS 1160 F
TRIVAC S/D 8 B	Part No. AS 1159 F
TRIVAC S/D 16 B + BCS with standard gaskets	Part No. AS 1158 F
TRIVAC S/D 25 B + BCS with standard gaskets	Part No. AS 1157 F
TRIVAC S/D 40/65 B + BCS with standard gaskets	Part No. AS 1156 F

¹⁾ Standard oil N 62

Comprehensive On-site Maintenance (with N 62) ²⁾

Comprehensive on-site maintenance includes the following:

Disassembly of the pump, cleaning of all individual components, replacement of all wearing parts, mounting of the pump including new gaskets and standard oil N 62, electrical safety test, test run including check of the attained ultimate pressure levels

Ordering Information

Comprehensive On-site Maintenance (with N 62) ²⁾

Ordering Information	Comprehensive On-site Maintenance (with N 62) ²⁾
For pump	
TRIVAC S 4 B	Part No. AS 1127 F
TRIVAC S 8 B	Part No. AS 1126 F
TRIVAC D 4 B	Part No. AS 1125 F
TRIVAC D 8 B	Part No. AS 1124 F
TRIVAC S 16 B	Part No. AS 1123 F
TRIVAC S 25 B	Part No. AS 1122 F
TRIVAC D 16 B	Part No. AS 1121 F
TRIVAC D 25 B	Part No. AS 1120 F
TRIVAC S 40 B	Part No. AS 1119 F
TRIVAC S 65 B	Part No. AS 1118 F
TRIVAC D 40 B	Part No. AS 1117 F
TRIVAC D 65 B	Part No. AS 1116 F
TRIVAC D 40 BCS with Viton gaskets	Part No. AS 1136 F
TRIVAC D 65 BCS with Viton gaskets	Part No. AS 1135 F
TRIVAC S 40 BCS with standard gaskets	Part No. AS 1134 F
TRIVAC S 65 BCS with standard gaskets	Part No. AS 1133 F
TRIVAC D 40 BCS with standard gaskets	Part No. AS 1132 F
TRIVAC D 65 BCS with standard gaskets	Part No. AS 1131 F

²⁾ Notes on our on-site after sales service

The listed services include the costs for material and working hours on site for standard TRIVAC pumps. Services for pump variants upon request.

Transportation and travelling expenses are invoiced at cost. All services refer to the repair of freely accessible and not contaminated vacuum components.

Complete Refurbishing at the Service Centre (with N 62)

Complete refurbishing at the service centre includes the following:

Disassembly of the pump, visual inspection of the subassemblies, replacement of all wearing parts, machined reworking of the pump module, mounting of the pump including new gaskets and standard oil N 62, electrical safety test, test run including check of the attained ultimate pressure levels.

Ordering Information

Complete Refurbishing at the Service Centre (with N 62)

For pump

TRIVAC S 4 B	Part No. AS 1127
TRIVAC S 8 B	Part No. AS 1126
TRIVAC D 4 B	Part No. AS 1125
TRIVAC D 8 B	Part No. AS 1124
TRIVAC S 16 B	Part No. AS 1123
TRIVAC S 25 B	Part No. AS 1122
TRIVAC D 16 B	Part No. AS 1121
TRIVAC D 25 B	Part No. AS 1120
TRIVAC S 40 B	Part No. AS 1119
TRIVAC S 65 B	Part No. AS 1118
TRIVAC D 40 B	Part No. AS 1117
TRIVAC D 65 B	Part No. AS 1116
TRIVAC D 40 BCS with Viton gaskets	Part No. AS 1136
TRIVAC D 65 BCS with Viton gaskets	Part No. AS 1135
TRIVAC S 40 BCS with standard gaskets	Part No. AS 1134
TRIVAC S 65 BCS with standard gaskets	Part No. AS 1133
TRIVAC D 40 BCS with standard gaskets	Part No. AS 1132
TRIVAC D 65 BCS with standard gaskets	Part No. AS 1131

Complete Refurbishing with Decontamination at the Service Centre (with N 62)

Complete refurbishing with decontamination at the service centre includes the following:

Disassembly of the pump, decontamination of the individual components, visual inspection of the individual subassemblies, replacement of all wearing parts, machined reworking of the pump module, mounting of the pump including new gaskets and standard oil N 62, electrical safety test, test run including check of the attained ultimate pressure levels.

Ordering Information

Complete Refurbishing with Decontamination at the Service Centre (with N 62)

For pump

TRIVAC S 4 B

TRIVAC S 8 B

TRIVAC D 4 B

TRIVAC D 8 B

TRIVAC S 16 B

TRIVAC S 25 B

TRIVAC D 16 B

TRIVAC D 25 B

TRIVAC S 40 B

TRIVAC S 65 B

TRIVAC D 40 B

TRIVAC D 65 B

TRIVAC D 40 BCS with Viton gaskets

TRIVAC D 65 BCS with Viton gaskets

TRIVAC S 40 BCS with standard gaskets

TRIVAC S 65 BCS with standard gaskets

TRIVAC D 40 BCS with standard gaskets

TRIVAC D 65 BCS with standard gaskets

Part No. AS 1127 D

Part No. AS 1126 D

Part No. AS 1125 D

Part No. AS 1124 D

Part No. AS 1123 D

Part No. AS 1122 D

Part No. AS 1121 D

Part No. AS 1120 D

Part No. AS 1119 D

Part No. AS 1118 D

Part No. AS 1117 D

Part No. AS 1116 D

Part No. AS 1155 D

Part No. AS 1154 D

Part No. AS 1134 D

Part No. AS 1133 D

Part No. AS 1132 D

Part No. AS 1131 D

Only available for purchase in North and South America

60 Hz Curves

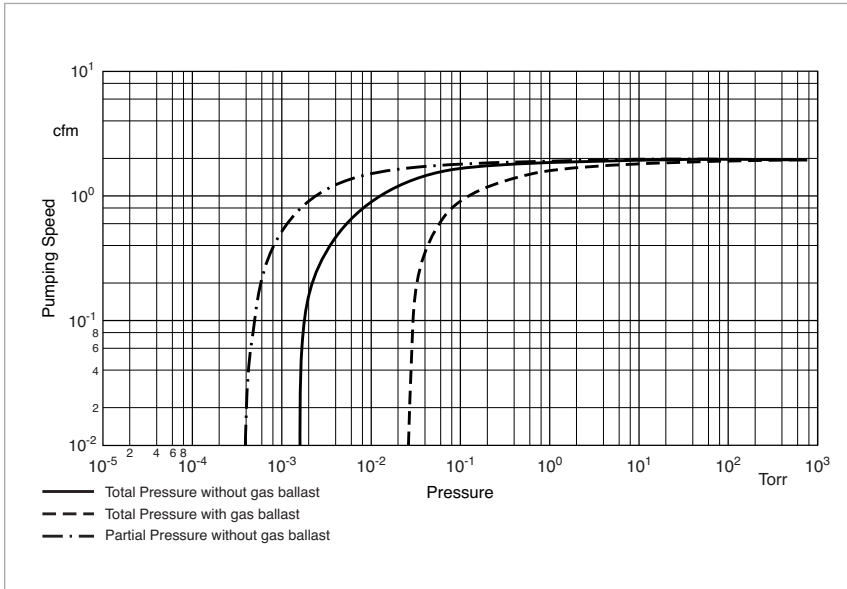

Pumping speed characteristics for the TRIVAC D 2.5 E at 60 Hz

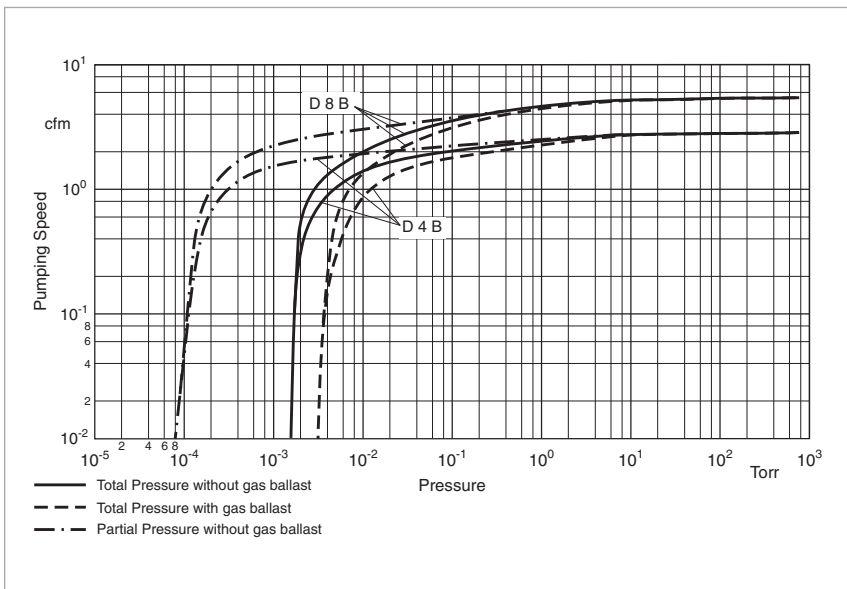

Pumping speed characteristics for the TRIVAC D 4 B and D 8 B at 60 Hz

Only available for purchase in North and South America

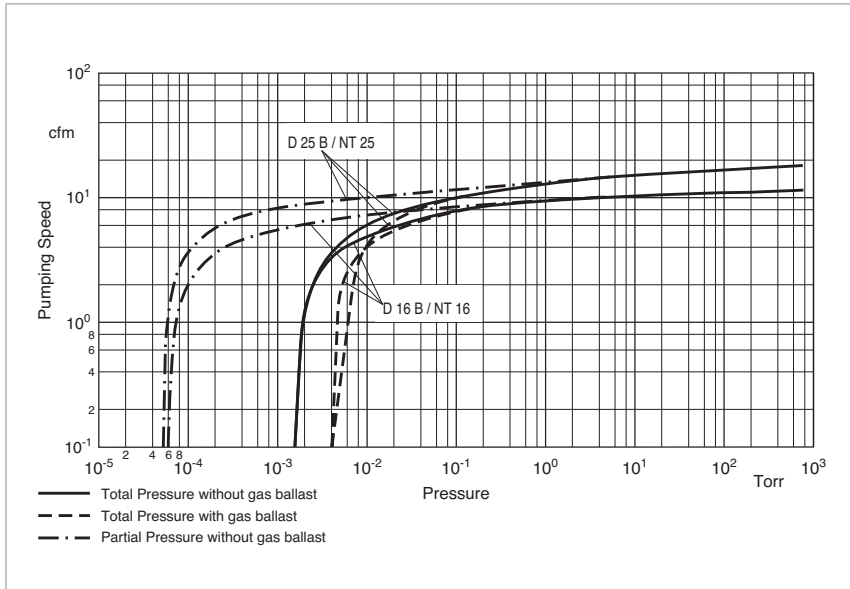

Pumping speed characteristics for the TRIVAC D 16 B/BCS, D 25 B/BCS and TRIVAC NT 16/25 at 60 Hz

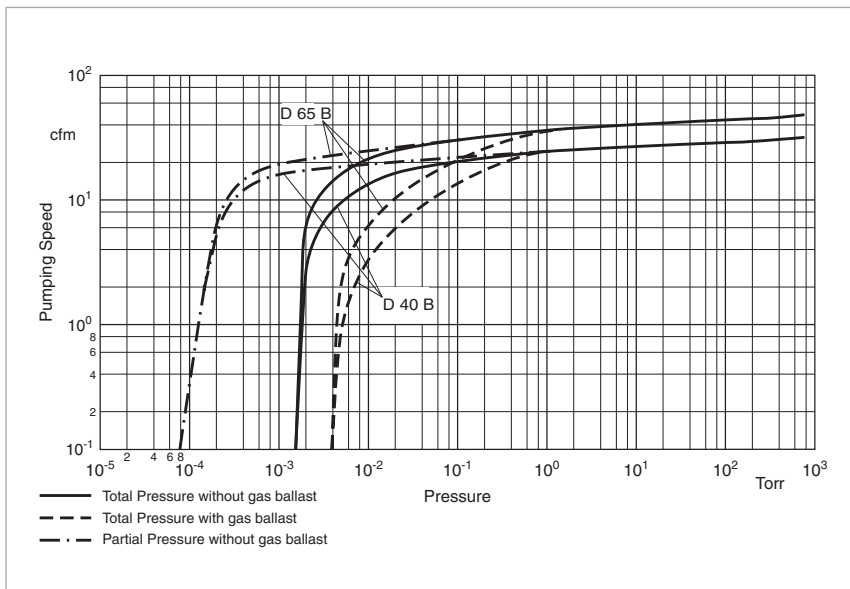

Pumping speed characteristics for the TRIVAC D 40 B/BCS and D 65 B/BCS at 60 Hz

Sales and Service

Germany

Oerlikon
Leybold Vacuum GmbH
Bonner Strasse 498
D-50968 Cologne
Phone: +49-(0)221-347 1234
Fax: +49-(0)221-347 1245
sales.vacuum@oerlikon.com
www.oerlikon.com

Oerlikon
Leybold Vacuum GmbH
Sales Area North/Northeast
Branch Office Berlin
Industriestrasse 10b
D-12099 Berlin
Phone: +49-(0)30-435 609 0
Fax: +49-(0)30-435 609 10
sales.vacuum.bn@oerlikon.com

Oerlikon
Leybold Vacuum GmbH
Sales Area South/Southwest
Branch Office Munich
Karl-Hammerschmidt-Strasse 34
D-85609 Aschheim-Dornach
Phone: +49-(0)89-357 33 9-10
Fax: +49-(0)89-357 33 9-33
sales.vacuum.mn@oerlikon.com
service.vacuum.mn@oerlikon.com

Oerlikon
Leybold Vacuum GmbH
Sales Area West & Benelux
Branch Office Cologne
Bonner Strasse 498
D-50968 Cologne
Phone: +49-(0)221-347 1270
Fax: +49-(0)221-347 1291
sales.vacuum.kn@oerlikon.com

Oerlikon
Leybold Vacuum GmbH
Service Competence Center
Emil-Hoffmann-Strasse 43
D-50996 Cologne-Suerth
Phone: +49-(0)221-347 1538
Fax: +49-(0)221-347 1945
service.vacuum.kn@oerlikon.com

Oerlikon
Leybold Vacuum GmbH
Mobil Customer Service
Emil-Hoffmann-Strasse 43
D-50996 Cologne-Suerth
Phone: +49-(0)221-347 2001
Fax: +49-(0)221-347 1944
service.vacuum.kn@oerlikon.com

Oerlikon
Leybold Vacuum
Dresden GmbH
Service Competence Center
Zur Wetterwarte 50, Haus 304
D-01109 Dresden
Service:
Phone: +49-(0)351-88 55 00
Fax: +49-(0)351-88 55 041
info.vacuum.dr@oerlikon.com

Oerlikon
Leybold Vacuum USA Inc.
5700 Mellon Road
USA-Export, PA 15632
Phone: +1-724-327-5700
Fax: +1-724-325-3577
info.vacuum.ex@oerlikon.com

Europe

Belgium
Oerlikon
Leybold Vacuum Nederland B.V.
Belgisch bijkantoor
Leuvensesteenweg 542-9A
B-1930 Zaventem
Sales:
Phone: +32-2-711 00 83
Fax: +32-2-720 83 38
sales.vacuum.zv@oerlikon.com
Service:
Phone: +32-2-711 00 82
Fax: +32-2-720 83 38
service.vacuum.zv@oerlikon.com

France
Oerlikon
Leybold Vacuum France S.A.
7, Avenue du Québec
Z.A. de Courtaboeuf 1 - B.P. 42
F-91942 Courtaboeuf Cedex
Sales and Service:
Phone: +33-1-69 82 48 00
Fax: +33-1-69 07 57 38
info.vacuum.ctb@oerlikon.com
sales.vacuum.ctb@oerlikon.com

Oerlikon
Leybold Vacuum France S.A.
Valence Factory
640, Rue A. Bergès
B.P. 107 640
F-26501 Bourg-lès-Valence Cedex
Service:
Phone: +33-4-75 82 33 00
Fax: +33-4-75 82 92 69
marketing.vacuum.vc@oerlikon.com

Great Britain

Oerlikon
Leybold Vacuum UK LTD.
Silverglade Business Park
Leatherhead Road Unit 2
KT9 2QL Chessington, Surrey
(London)
Sales:
Phone: +44-13-7273 7300
Fax: +44-13-7273 7301
sales.vacuum.ln@oerlikon.com
Service:
Phone: +44-20-8971 7030
Fax: +44-20-8971 7003
service.vacuum.ln@oerlikon.com

Italy

Oerlikon
Leybold Vacuum Italia S.r.l.
Via Trasimeno 8
I-20128 Milano
Sales:
Phone: +39-02-27 22 31
Fax: +39-02-27 20 96 41
sales.vacuum.mi@oerlikon.com
Service:
Phone: +39-02-27 22 31
Fax: +39-02-27 22 32 17
service.vacuum.mi@oerlikon.com

Netherlands

Oerlikon
Leybold Vacuum Nederland B.V.
Proostwetering 24N
NL-3543 AE Utrecht
Sales and Service:
Phone: +31-(30) 242 6330
Fax: +31-(30) 242 6331
sales.vacuum.ut@oerlikon.com
service.vacuum.ut@oerlikon.com

Spain

Oerlikon
Leybold Vacuum Spain, S.A.
C/ Huelva 7
E-08940 Cornellà de Llobregat
(Barcelona)
Sales:
Phone: +34-93-666 43 11
Fax: +34-93-666 43 70
sales.vacuum.ba@oerlikon.com
Service:
Phone: +34-93-666 46 16
Fax: +34-93-685 43 70
service.vacuum.ba@oerlikon.com

Switzerland

Oerlikon
Leybold Vacuum Schweiz AG
Leutschenbachstrasse 55
CH-8050 Zürich
Sales:
Phone: +41-44-308 40 50
Fax: +41-44-302 43 73
sales.vacuum.zh@oerlikon.com
Service:
Phone: +41-44-308 40 62
Fax: +41-44-308 40 60
service.vacuum.zh@oerlikon.com

America

Oerlikon
Leybold Vacuum USA Inc.
5700 Mellon Road
USA-Export, PA 15632
Phone: +1-724-327-5700
Fax: +1-724-325-3577
info.vacuum.ex@oerlikon.com
Sales:
Eastern & Central time zones
Phone: +1-724-327-5700
Fax: +1-724-333-1217
Pacific, Mountain, Alaskan &
Hawaiian time zones
Phone: +1-408-436-2828
Fax: +1-408-436-2849
Service:
Phone: +1-724-327-5700
Fax: +1-724-325-3577

Asia

P.R. China

Oerlikon
Leybold Vacuum (Tianjin)
International Trade Co. Ltd.
Beichen Economic
Development Area (BEDA),
No.8 Western Shuangchen Road
Tianjin 300400
China
Sales and Service:
Phone: +86-22-2697 0808
Fax: +86-22-2697 4061
Fax: +86-22-2697 2017
info.vacuum.tj@oerlikon.com
sales.vacuum.tj@oerlikon.com
service.vacuum.tj@oerlikon.com

Oerlikon
Leybold Vacuum
(Tianjin) Co. Ltd.
Beichen Economic
Development Area (BEDA),
No.8 Western Shuangchen Road
Tianjin 300400
China
Sales and Service:
Phone: +86-22-2697 0808
Fax: +86-22-2697 4061
info.vacuum.tj@oerlikon.com
sales.vacuum.tj@oerlikon.com
service.vacuum.tj@oerlikon.com

Oerlikon
Leybold Vacuum (Tianjin)
International Trade Co. Ltd.
Shanghai Branch:
No.33
76 Fu Te Dong San Road
Waigaoqiao Free Trade Zone
Shanghai 200131
China
Sales and Service:
Phone: +86-21-5064-4666
Fax: +86-21-5064-4668
info.vacuum.sh@oerlikon.com
sales.vacuum.sh@oerlikon.com
service.vacuum.sh@oerlikon.com

Oerlikon
Leybold Vacuum (Tianjin)
International Trade Co. Ltd.
Guangzhou Office and
Service Center
1st F, Main Building
Science City Plaza,
No.111 Science Revenue,
Guangzhou Science City
(GZSC) 510663, Guangzhou,
China
Sales:
Phone: +86-20-223 23 980
Fax: +86-20-223 23 990
info.vacuum.gz@oerlikon.com
sales.vacuum.gz@oerlikon.com
service.vacuum.gz@oerlikon.com

Oerlikon
Leybold Vacuum (Tianjin)
International Trade Co. Ltd.
Beijing Branch:
1-908, Beijing Landmark Towers
8 North Dongsanhuan Road
Beijing 100004
China
Sales:
Phone: +86-10-6590-7622
Fax: +86-10-6590-7607
sales.vacuum.bj@oerlikon.com
service.vacuum.bj@oerlikon.com

India

Oerlikon
Leybold Vacuum India Pvt Ltd.
EL 22, J-Block
MIDC Bhosari
Pune 411026
India
Sales and Service:
Phone: +91-20-3061 6000
Fax: +91-20-2712 1571
sales.vacuum.pu@oerlikon.com
service.vacuum.pu@oerlikon.com

Oerlikon
Leybold Vacuum GmbH
Bonner Strasse 498
D-50968 Cologne
Phone: +49-(0)221-347 0
Fax: +49-(0)221-347 1250
info.vacuum@oerlikon.com

Japan

Oerlikon
Leybold Vacuum
Japan Co., Ltd.
Headquarter
23-3, Shin-Yokohama
3-chome
Tobu A.K. Bldg. 4th Floor
Kohoku-ku
Yokohama-shi 222-0033
Sales:
Phone: +81-45-471-3330
Fax: +81-45-471-3323
info.vacuum.yh@oerlikon.com
sales.vacuum.yh@oerlikon.com

Oerlikon
Leybold Vacuum
Japan Co., Ltd.
Osaka Sales Office
3F, Shin-Osaka Terasaki
No.3 Bldg.
1-5-28 Nishi-Miyahara
Yodogawa-ku, Osaka-shi
Osaka 532-0004
Phone: +81-6-6399-6271
Fax: +81-6-6399-6273
info.vacuum.os@oerlikon.com
sales.vacuum.os@oerlikon.com

Oerlikon
Leybold Vacuum
Japan Co., Ltd.
Tsukuba Technical Service Center
Kogyo Danchi
21, Kasuminosato,
Ami-machi, Inashiki-gun
Ibaraki-ken, 300-0315
Service:
Phone: +81-298 89 2841
Fax: +81-298 89 2838
info.vacuum.iik@oerlikon.com
sales.vacuum.iik@oerlikon.com

South Korea

Oerlikon
Leybold Vacuum Korea Ltd.
3F, Jellzone 2 Tower
Jeongja-dong 159-4
Bundang-gu Sungnam-si
Gyeonggi-do
Bundang 463-384, Korea
Sales:
Phone: +82-31 785 1367
Fax: +82-31 785 1359
sales.vacuum.bd@oerlikon.com

Service:
623-7, Upsung-Dong
Cheonan-Si
Chungcheongnam-Do
Burea 330-290
Phone: +82-41 589 3035
Fax: +82-41 588 0166
service.vacuum.cn@oerlikon.com

Singapore

Oerlikon
Leybold Vacuum
Singapore Pte Ltd.
1 Science Park Road
Singapore Science Park 2
#02-12, Capricorn Building
Singapore 117528
Sales and Service:
Phone: +65-6303 7030
Fax: +65-6773 0039
sales.vacuum.sg@oerlikon.com
service.vacuum.sg@oerlikon.com

Taiwan

Oerlikon
Leybold Vacuum Taiwan Ltd.
No 416-1, Sec. 3
Chungshin Road., Chutung
Hsinchu County 310
Taiwan, R.O.C.
Sales and Service:
Phone: +886-3-500 1688
Fax: +886-3-583 3999
sales.vacuum.hc@oerlikon.com
service.vacuum.hc@oerlikon.com

oerlikon
leybold vacuum
www.oerlikon.com/leyboldvacuum