

Models M870 and DM870 Specifications

ENVIRONMENTAL RATINGS

Operating Temperature Range

Model M870	-65 °C to +125 °C
Model DM870	-65 °C to +110 °C

Non-Operating Temperature Range

Range -65 °C to +125 °C

Humidity MIL-STD-202F, Method 103B,
Cond. B (96 hrs. at 95%)

Shock MIL-STD-202F, Method 213B,
Cond. B (75G, 6 msec)

Vibration MIL-STD-202F, Method 204D,
Cond. B (.06" double amplitude
or 15G, whichever is less)

Altitude MIL-STD-202F, Method 105C,
Cond. B (50,000 ft.)

Temp. Cycling MIL-STD-202F, Method 107D,
Cond. A, 5 cycles

AVAILABLE OPTIONS

Option No.	Description
7	SMA male rf connectors
7A	J1 SMA male; J2 and J3 SMA female
7B	J1 SMA female; J2 and J3 SMA male
9	Inverse control logic; logic "0" for port ON and logic "1" for port OFF (available only in conjunction with Option 22)
20 ⁽¹⁾	Two unit load control input impedance
22	Individual port control (DM 870 only — one unit load); logic "0" for port OFF and logic "1" for port ON. Also available with logic "0" for port ON and logic "1" for port OFF (Specify Option 9)
33	EMI Filter solder-type bias/control terminal
64A	SMB male bias/control connector

(1) Not applicable to Model M870. All Models DM870 are furnished with this option unless otherwise specified by customer. Other options, such as 50 ohms to ground, are available on special order.

DIMENSIONS AND WEIGHTS

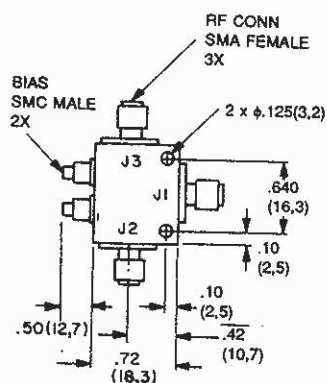

MODEL M870
Wt: 1.5 oz. (43 gm) approx.

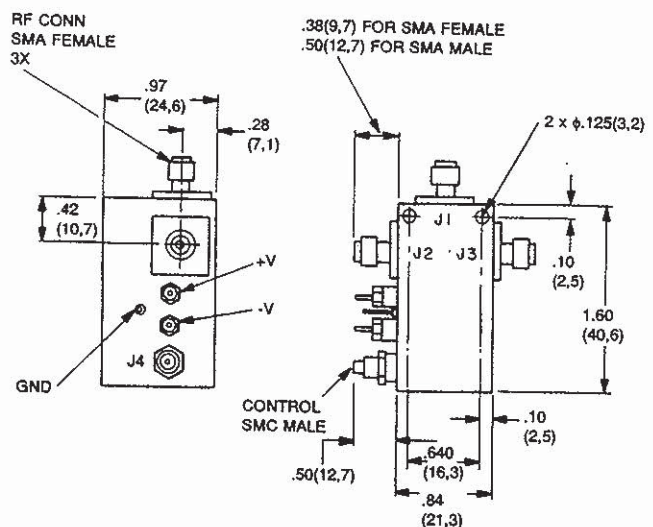
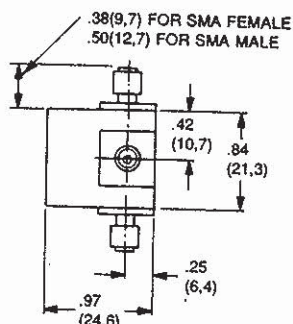

MODEL DM870
Wt: 2.5 oz (71 gm) approx.

Dimensional Tolerances, unless otherwise indicated: .XX ± .02; .XXX ± .005



Series F892

High-Speed Octave-Band SP2T Switches

SERIES F892

Series F892 high speed switches with integrated drivers are low-cost units that have been engineered to meet the need of microwave system designers for fast switching devices in small packages.

2 To 18 GHz Frequency Range

Frequency coverage from 2 to 18 GHz is provided by the three models in the Series: Model F8922 (2-4 GHz), Model F8924 (4-8 GHz) and Model F8928 (8-18 GHz). Each model is capable of extended bandwidth operation, typically 3:1, with only moderate degradation in performance at the band edges, as shown in the specifications on page 103.

Fast Switching Shunt Design

All models are optimally designed, with respect to their size, for low VSWR and insertion loss. As shown in the schematic below, a pure shunt design is used for the most practical realization of fast switching action. Although the use of a pure shunt mode imposes certain bandwidth limitations, frequency coverage in excess of octave bands has been maintained.

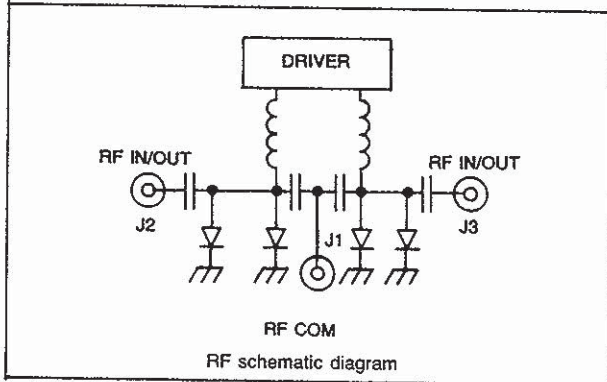

The proper currents required to switch ports ON or OFF are provided by the integrated drivers which are controlled by external logic signals.

- Low Cost
- S, C and X-U band models
- 10 nsec rise and fall times
- Up to 60 dB isolation
- As low as 1.0 dB insertion loss

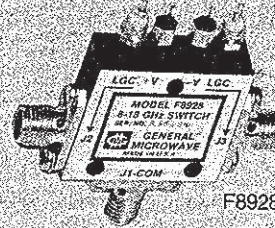

F8928

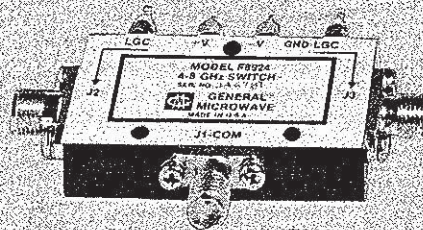

F8924

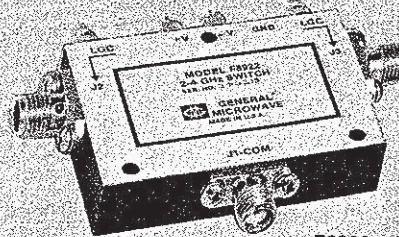

F8922

THE THREE UNITS
IN THIS SERIES
ARE EQUIPPED WITH
INTEGRATED DRIVERS



Series F892 Specifications

PERFORMANCE CHARACTERISTICS

MODEL NO.	FREQUENCY RANGE (GHz)	INSERTION LOSS, MAX. (dB)	ISOLATION MIN. (dB)	VSWR MAX. (ON)
F8922	2-4	1.0	60	1.5
	15-4.5	2.0	55	2.0
F8924	4-8	1.4	50	1.5
	3-9	2.3	45	2.2
F8928	8-18	2.3	45 ⁽²⁾	2.2
	6-18	2.5	45 ⁽²⁾	2.5

Switching Characteristics

Rise Time	10 nsec max.
Fall Time	10 nsec max.
ON Time	35 nsec max.
OFF Time	30 nsec max.
Repetition rate	10 MHz max.

Power Handling Capability

Without Performance Degradation	2W cw or peak ⁽¹⁾
Survival Power	2W average, 75W peak (1 μsec max pulse width)

Control Characteristics

Control Input	
Impedance	Schottky TTL, one-unit load. (A unit load is 2.0 mA sink current and 50 μA source current.)
Control Logic	Logic "0" (-0.3 to +0.8V) for port ON and logic "1" (+2.0 to +5.0V) for port OFF

Power Supply Requirements

(For one port ON)	+5V ± 5%, 65 mA
	-12 to -15V ⁽¹⁾ , 2 mA

ENVIRONMENTAL RATINGS

Operating Temperature

Range -65°C to +110°C

Non-Operating Temperature

Range -65°C to +125°C

Humidity

MIL-STD-202F, Method 103B, Cond. B (96 hrs. at 95%)

Shock

MIL-STD-202F, Method 213B, Cond. B (75G, 6msec)

Vibration

MIL-STD-202F, Method 204D, Cond. B (.06" double amplitude or 15G, whichever is less)

Altitude

MIL-STD-202F, Method 105C, Cond. B (50,000 ft.)

Temp. Cycling

MIL-STD-202F, Method 107D, Cond. A, 5 cycles

AVAILABLE OPTIONS

Option No.	Description
3	SMA female control connectors
7	SMA male rf connectors
7A	J1 SMA male; J2 and J3 SMA female
7B	J1 SMA female; J2 and J3 SMA male
9	Inverse control logic; logic "0" for port OFF and logic "1" for port ON
27	Single-port toggle control; logic "0" connects J1 to J2
62	± 15V operation
64	SMC male control connectors
64A	SMB male control connectors
65	± 12V operation

(1) With -15V power supply. Reduces to 1.5W with -12V power supply. Units can be operated at higher input power levels some increase in switching time when -30V power supply is used.
 (2) Isolation 40 dB above 16 GHz.

